

TL
Tony Little
AMERICA'S PERSONAL TRAINER
INSTRIDE®
TREADMILL

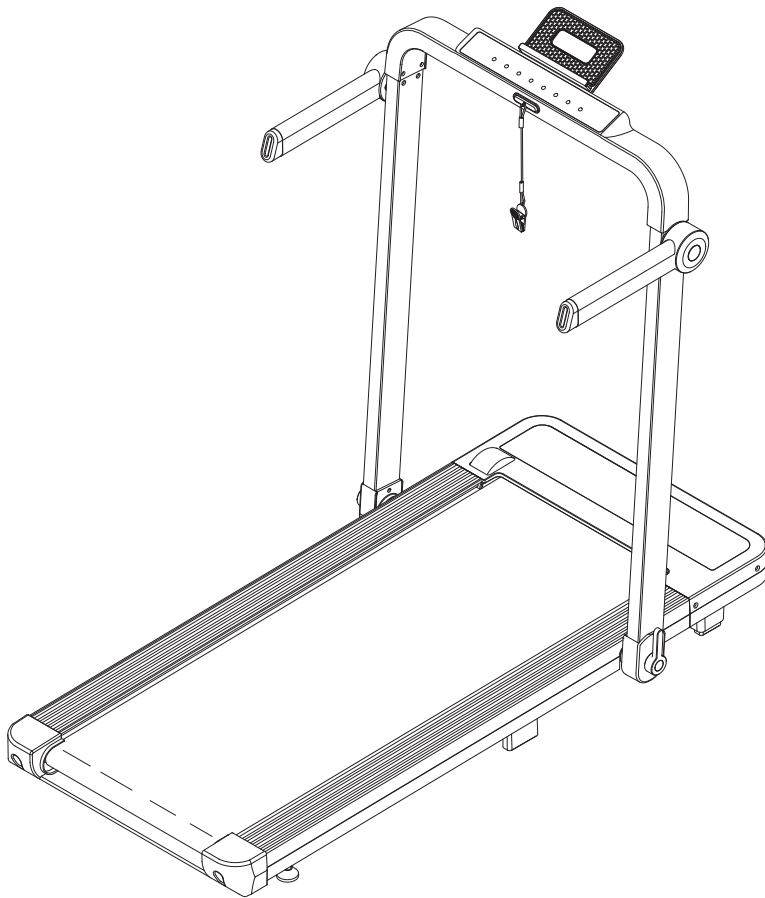

Download the müüv app
for a step-by-step assembly video

Owner's Manual



Product May Vary Slightly From Pictured.

CAUTION:
Weight on this product should not exceed 250 lbs.

⚠ WARNING

- Exercise can present a health risk. Consult a physician before beginning any exercise program with this equipment. If you feel faint or dizzy, immediately discontinue use.
- Serious bodily injury can occur if this equipment is not assembled and used in accordance with the owner's manual.
- Follow all safety instructions in this owner's manual.

When calling for parts or service, please specify the following numbers:

**Model#: 45-9850,
45-9851**

S/N: _____

This Product is Distributed Exclusively by



2040 N Alliance Ave, Springfield, MO 65803
Customer Care
1 (800) 375-7520
www.staminaproducts.com

STAMINA PRODUCTS
MADE IN CHINA

©2024 Stamina Products, Inc.
2024, 02

müüv

Quickstart Guide

IMPORTANT

Download the müüv app to experience personalized fitness coaching for your Tony Little Treadmill!
müüv also supports other exercise equipment you own and hundreds of healthy activities like outdoor walking to make moving fun!



Go to the App Store on your device or scan the QR Code for quick access.



DOWNLOAD APP

**Unlimited workouts for the Tony Little Treadmill
Assembly video included in the app
No subscription required**

TABLE OF CONTENTS

Safety Instructions	3	Maintenance	16
FCC Statements	4	Conditioning Guidelines	18
Grounding Instructions	5	Warm-Up and Cool-Down	19
Before You Begin	7	Product Parts Drawing	20
Equipment Warning, Caution & Notice Labels ...	8	Parts List	21
Operational Instructions	9	Warranty	23
Storage	16	Fax/Mail Ordering Form	25

SAFETY INSTRUCTIONS

⚠ WARNING Cancer and Reproductive Harm www.P65Warnings.ca.gov

⚠ WARNING Consult your physician before starting this or any exercise program. This is especially important if you are over the age of 35, have never exercised before, are pregnant, or suffer from any health problem. This product is for home use only. Do not use in institutional or commercial applications. Failure to follow all warnings and instructions could result in serious injury or death.

⚠ WARNING To reduce the risk of serious injury, read the following Safety Instructions before using the inStride Treadmill.

- To reduce the risk of electrical shock, always unplug the power cord before performing the maintenance, adjustments and cleaning procedures described in this manual.
- The inStride Treadmill should never be left unattended when plugged in. Unplug from outlet when not in use.
- The inStride Treadmill is not intended for use by persons with reduced physical, sensory or mental capabilities, or lack of experience or knowledge, unless they have been given supervision or instruction concerning use by a person responsible for their safety.
- Use the inStride Treadmill only for its intended use as described in this manual. Do not use attachments not recommended by the manufacturer.
- To disconnect, turn all controls to the off position, then unplug from the outlet.
- Connect the inStride Treadmill to a properly grounded outlet only, See Grounding Instructions.
- The inStride Treadmill should only be used after a thorough review of the Owner's Manual by all exercisers and saved for future reference.
- Make sure that the product is properly assembled and tightened before use.
- We recommend that two people be available for assembly of this product.
- Keep children under age 13 and pets away from the inStride Treadmill at all times. This product is for adult use only.
- It is recommended that you place this product on an equipment mat.
- Set up and operate the inStride Treadmill on a solid level surface. Do not position the product on loose or uneven surfaces.
- Do not place the inStride Treadmill on thick carpet as it may interfere with proper ventilation. Also, do not place the inStride Treadmill near water or outdoors.
- Position the inStride Treadmill so that the wall plug is visible, accessible and away from heated surfaces.
- Make sure that adequate space of 4 feet wide x 6 feet long is available for access to and around the product.
- Keep fingers clear of all pinch points when folding and unfolding the inStride Treadmill.
- Before using, always inspect the product for worn parts that should be replaced or loose parts that should be tightened.
- Never move the Walking Belt (10) while the power is turned off. Do not operate the inStride Treadmill if the power cord or plug is damaged, or if the treadmill is not working properly.

SAFETY INSTRUCTIONS

- Always make sure the Uprights (2, 3) are locked properly by the Fixing Lever (19).
- Always attach the Safety Key (50) to your clothing while using the inStride Treadmill.
- Do not step off the inStride Treadmill while it is in motion.
- Keep hands and fingers away from moving parts and avoid touching the belt during operation.
- Maintain proper posture and do not lean excessively on the handrails.
- Start with a slow pace and gradually increase speed and intensity.
- Avoid sudden speed or incline changes, as they may lead to loss of balance and accidents.
- Stay hydrated during your workout.
- Do not use the inStride Treadmill if you are under the influence of alcohol or medication that may affect your balance or coordination.
- Always choose the workout which best fits your physical strength and flexibility level. Know your limits and train within them.
- Do not wear loose clothing while using the inStride Treadmill.
- Always wear proper footwear such as running, walking, or cross training shoes.
- Be careful to maintain your balance while assembling, mounting, using and dismounting the inStride Treadmill. Loss of balance may result in a fall or serious bodily injury.
- The inStride Treadmill should not be used by persons weighing over 250 pounds.
- The inStride Treadmill should be used by only one person at a time.
- The inStride Treadmill is for consumer use only. It is not for use in public or semipublic facilities.
- To reduce the possibility of the treadmill overheating, do not operate the inStride Treadmill continuously for longer than one hour.

FCC Statements:

This equipment has been tested and found to comply with the limits for a Class B digital device, pursuant to Part 15 of the FCC Rules. These limits are designed to provide reasonable protection against harmful interference in a residential installation.

This equipment generates, uses and can radiate radio frequency energy. However, there is no guarantee that interference will not occur in a particular installation. If this equipment does cause harmful interference to radio or reception, which can be determined by turning the equipment off and on, the user is encouraged to try to correct the interference by one or more of the following measures:

- Reorient or relocate the receiving antenna.
- Increase the separation between the equipment and receiver.
- Connect the equipment into an outlet on a circuit different from that to which the receiver is connected.
- Consult the dealer or an experienced technician for help.

This device complies with part 15 of the FCC Rules. Operation is subject to the following two conditions:

- 1) This device may not cause harmful interference, and
- 2) This device must accept any interference received, including interference that may cause undesired operation.

MODIFICATION: Any changes or modifications not expressly approved by the grantee of this device could void the user's authority to operate the device.

GROUNDING INSTRUCTIONS

The müüv Treadmill must be grounded. If a treadmill should malfunction or breakdown, grounding provides a path of least resistance for electrical current to reduce the risk of electrical shock. The müüv Treadmill is equipped with a cord having an equipment grounding conductor and a grounding plug. The plug must be plugged into an appropriate outlet that is properly installed and grounded in accordance with local codes and ordinances.

⚠ WARNING Improper connection of the equipment grounding conductor can result in a risk of electric shock. Check with a qualified electrician or serviceman if you are in doubt as to whether the product is properly grounded. Do not modify the plug provided with the product. If it will not fit the outlet, have a proper outlet installed by a qualified electrician.

The müüv Treadmill is for use on a nominal 110-volt circuit and has a grounding plug that looks like the plug as showed in the illustration below. Make sure the müüv Treadmill is connected to an outlet having the same configuration as the plug. No adapter should be used with this product. (This picture is just for reference.)

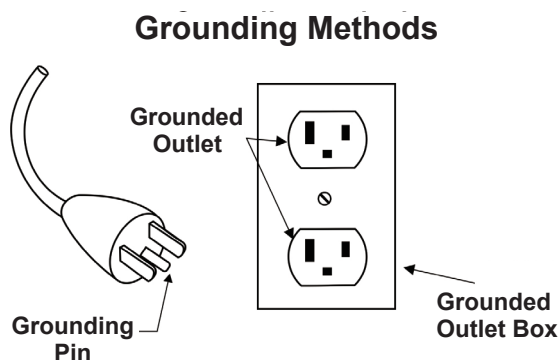

Treadmill Safety Key Use:

Using the **SAFETY KEY(50)** is a straightforward process designed to enhance user safety. Here's a step-by-step guide on how to use the **SAFETY KEY(50)**. **The SAFETY KEY(50) must be inserted for "Walking Mode" as well as "Treadmill Mode" for the treadmill to work properly.**

1. Identify the safety key notch at the front center of the control panel.
2. Ensure that the **SAFETY KEY(50)** is not damaged or worn. If you notice any issues, such as a frayed cord or a malfunctioning clip, replace the **SAFETY KEY(50)** before use.
3. Insert the **SAFETY KEY(50)** into the notch on the control panel. Push it in until it's fully engaged.
4. Attach the clothespin clip to your clothes in front of your chest or the nearest location. This ensures that the key is readily accessible during your workout.

NOTE: Not required for "Walking Mode". Ensure the lanyard and clip do not come in contact with the **WALKING BELT(10)**.

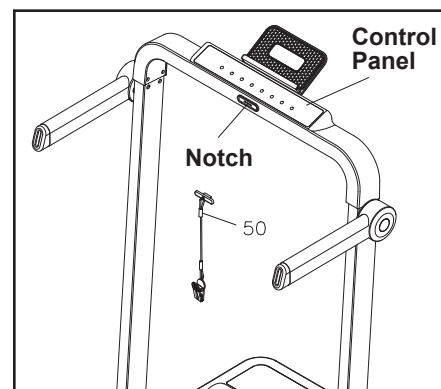

5. Turn on the power switch, the LED display will be fully displayed with a prompt sound.
WALKING MODE: Use the **REMOTE CONTROL(49)** to operate the functions of the treadmill.
TREADMILL MODE: You can use the **REMOTE CONTROL(49)** or use the function buttons on the control panel to operate the treadmill.
NOTE: See manual for full control panel and remote control instructions.
6. Before starting your workout, double-check that the **SAFETY KEY(50)** is securely in place and properly connected to the control panel.
7. Once the **SAFETY KEY(50)** is in position and the treadmill is powered on, you can start your workout as usual.
NOTE: Always mount and dismount the treadmill while the **WALKING BELT(10)** is not moving.
8. In case of emergency or if you need to stop the treadmill quickly, simply detach the **SAFETY KEY(50)** from the control panel by pulling it out of the notch. This action will trigger an immediate stop, bringing the treadmill to a halt.

NOTE: Always stop the treadmill when switching between "Walking Mode" and "Treadmill Mode".

EXTEND YOUR PARTS WARRANTY TO 180 DAYS FROM THE DATE OF PURCHASE. REGISTER YOUR PRODUCT.



**NEED HELP?
CONTACT US FIRST
1 (800) 375-7520
customer.care@staminaproducts.com**

Hi! From all of us here at Stamina Products, thank you for your purchase. We know that you have big fitness goals in mind and we are here to help you along. Call us, email us, or send us a message on Facebook. Be sure to contact us if you have any questions on your new product. We look forward to hearing from you!

With your body in mind,
Stamina Customer Care

To enact your extended warranty and to help us better serve you, please go online and register your new product.

register.staminaproducts.com

It is quick and easy to register online, but if you're a little old school or just need a reason to raise that little flag on your mailbox, fill out the info on the last page of this manual and mail it in.



ONLINE

customer.care@staminaproducts.com
www.staminaproducts.com



TELEPHONE

1 (800) 375-7520



FAX

(417) 889-8064



MAIL

Stamina Products, Inc.
ATTN: Customer Care
2040 N Alliance Ave
Springfield, MO 65803

 facebook.com/StaminaProducts
facebook.com/AeroPilates

CUSTOMER CARE HOURS:
Monday-Thursday, 7:30 AM-5:00 PM, Central Time
Friday, 8:00 AM-3:00 PM, Central Time

BEFORE YOU BEGIN

Thank you for choosing the inStride Treadmill. We take great pride in this quality product and hope it will provide many hours of quality exercise to make you feel better, look better, and enjoy life to its fullest.

It's a proven fact that a regular exercise program can improve your physical and mental health. Too often, our busy lifestyles limit our time and opportunity to exercise. The inStride Treadmill provides a convenient and simple method to begin your journey of getting your body in shape and achieving a happier and healthier lifestyle.

Before reading further, please review the drawing below and familiarize yourself with the parts that are labeled. Locate the serial decal on the product and write the serial number on the cover of the manual in the space provided. See the next page for an image of the serial decal. Model number and serial number are required when

calling for assistance.

Read this manual carefully before using the inStride Treadmill.

Providing you with a quality product is Stamina's top priority. However, sometimes there could be a missing or incorrectly sized part. If you have any questions or problems with the parts included with your inStride Treadmill, please do not return the product. Contact us **FIRST!**

If a part is missing or defective, please contact Customer Care for assistance. Call us toll free at 1-800-375-7520 (in the U.S.) or live chat on staminaproducts.com. Our Customer Care Staff is available to assist you from 7:30 A.M. to 5:00 P.M. (Central Time) Monday through Thursday and 8:00 A.M. to 3:00 P.M. (Central Time) on Friday.

Be sure to have the name and model number of the product available when you contact us.

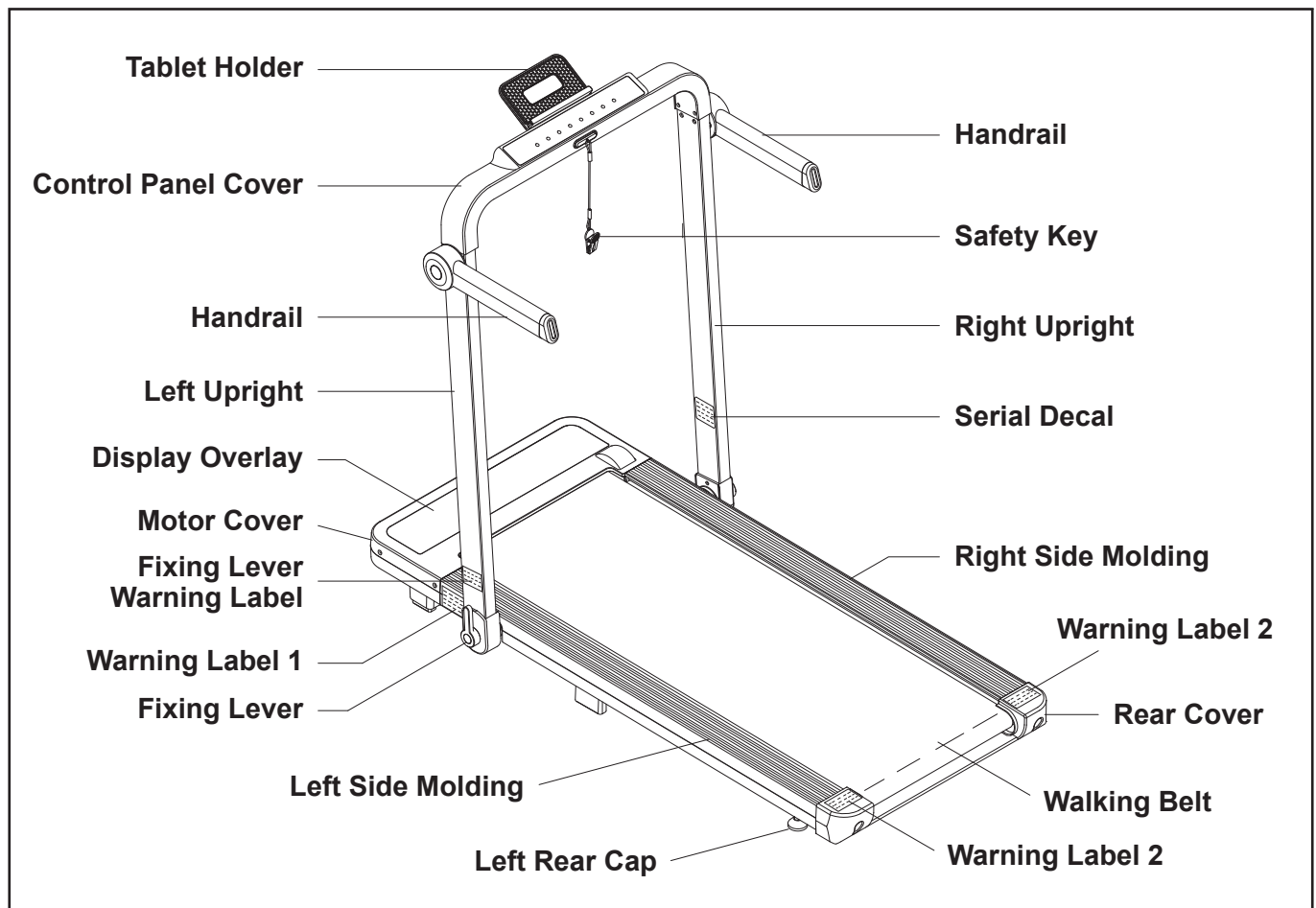

THE FOLLOWING TOOLS ARE INCLUDED FOR ASSEMBLY :

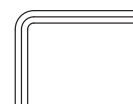

Allen Wrench (6mm)

EQUIPMENT WARNING, CAUTION & NOTICE LABELS

This chart is provided to help identify the warning, caution, and notice labels on the inStride Treadmill. Please take a moment to familiarize yourself with all of the warning, caution, and notice labels.

INTERTEK ETL LABEL(85)

Stamina Products, Inc. 2040 N. Alliance Ave Springfield, MO 65803 1-800-375-7520 MADE IN CHINA	Model: 45-9850/45-9851 Motor: 1.0 HP DC, Class A Power: 735 W Ratings: 120V, 6A, 60Hz FOR CONSUMER USE ONLY	Max. User Weight: 250lbs Contains FCC ID: AUJE-FSBTC Conforms to UL STD 1647 Certified to CSA STD C22.2 #68	This device complies with Part 15 of the FCC Rules. Operation is subject to the following two conditions: (1) this device may not cause harmful interference, and (2) this device must accept any interference received, including interference that may cause undesired operation of the device.	
--	---	--	---	---

WARNING LABEL 3 (88)

 WARNING	Treadmill functions with handlebars in down position.
--	---

WARNING LABEL 2 (83)

 WARNING
Exposed moving parts can cause injury. Keep shoelaces, loose clothing, and accessories away from the walking surface.
<ul style="list-style-type: none"> • This product is for adult consumer use only. Keep children under age 13 and pets away from the treadmill at all times. • Keep the area around and behind the treadmill clear at all times. • For more safety information, please refer to your Owner's Manual and/or www.staminaproducts.com.

FIXING LEVER WARNING LABEL (84)

 WARNING
Secure fixing lever prior to use and after folding

WARNING LABEL 1 (82)

 WARNING
Failure to follow all warnings and instructions could result in serious injury or death. Before assembling or using this product, read and follow the Owner's Manual and all other warnings and instructions that accompany this product. Replace this warning label if damaged, illegible, or removed.
Keep others, including children under age 13 & pets away from equipment when in use.
Unplug the product and remove the safety key before servicing, cleaning or when not in use. Always store the safety key away from the treadmill and out of the reach of children.
Do not touch moving parts, as they can cause injury. Keep shoelaces, loose clothing and accessories away from walking surface. Use caution when stepping on and off the product.
Consult your physician before starting this or any exercise program. This is especially important if you are over the age of 35 or have any pre-existing health conditions. Always make sure all nuts and bolts are securely tightened before using this product. This product should not be used by persons weighing more than 250 lbs, unless otherwise stated in your Owner's Manual.

SERIAL DECAL(86)

GUARANTEED PERFORMANCE	
	
Customer Care	
1 (800) 375-7520	
Mon-Thurs • 7:30am - 5pm, Fri • 8am - 3pm CST FAX: (417) 889-8064 • www.staminaproducts.com MADE IN CHINA	
Model #	Serial #
45-9800	

To best serve you, our Customer Care Representatives will need your serial number. For quick access, write in your serial number on the cover of the manual.

OPERATIONAL INSTRUCTIONS

Place all parts from the box in a cleared area and position them on the floor in front of you. Remove all packing materials from your area and place them back into the box. Do not dispose of the packing materials until assembly is completed. Read each step carefully before beginning. If you are missing a part, please go to staminaproducts.com under the Customer Care section and order the part needed, e-mail us at customer.care@staminaproducts.com, or call us toll free at 1-800-375-7520 (in the U.S.). Our Customer Care Staff is available to assist you from 7:30 A.M. to 5:00 P.M. (Central Time) Monday through Thursday and 8:00 A.M. to 3:00 P.M. (Central Time) on Friday.

Some product parts are fit tested at the factory to ensure proper fit and alignment. Marks in the paint may be noticeable, but are not an indication of damage.

WALKING MODE

The inStride Treadmill is a fully assembled product. Remove the inStride Treadmill from its carton, and remove all packing materials from the product. Place the inStride Treadmill as shown in the illustration below. Check and make sure the **FIXING LEVERS(19)** are securely tightened. Plug the **POWER CORD(51)** into the socket on the front of the **MAIN FRAME(1)**, and plug the **POWER CORD(51)** into an electrical outlet. Then you can use the inStride Treadmill in its walking mode directly.

- NOTE:**
1. You should use the **REMOTE CONTROL(49)** to operate the functions of the inStride Treadmill in the walking mode.
 2. The maximum speed of the walking mode is 2.5 miles per hour.

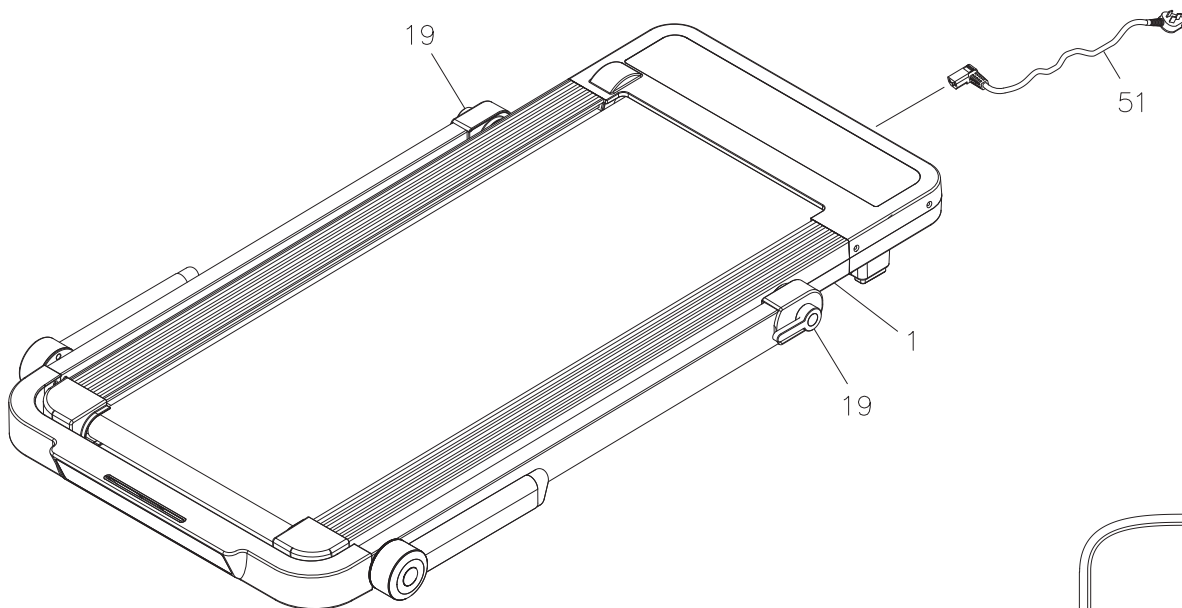

REMOTE CONTROL(49)
See page 13 for detailed remote operational instructions.

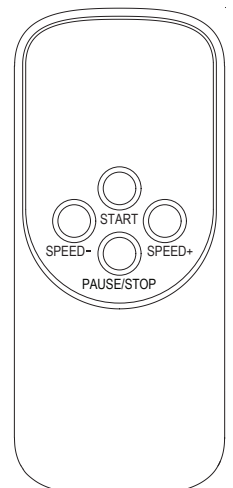

OPERATIONAL INSTRUCTIONS

TREADMILL MODE

Follow the illustrated process below to unfold the inStride Treadmill to go into the treadmill mode:

1. Refer to illustration 1. Turn the **FIXING LEVERS(19)** counterclockwise 4 to 5 turns to loosen the **LEFT** and **RIGHT UPRIGHTS(2, 3)**. Lift up the **UPRIGHTS(2, 3)** to the "stop" and lock in position by turning the **FIXING LEVERS(19)** clockwise. Always make sure the **FIXING LEVERS(19)** are securely tightened.
2. Refer to illustration 2. Swing the **HANDRAILS(4)** around as shown in the illustration so they point to the back of the treadmill.

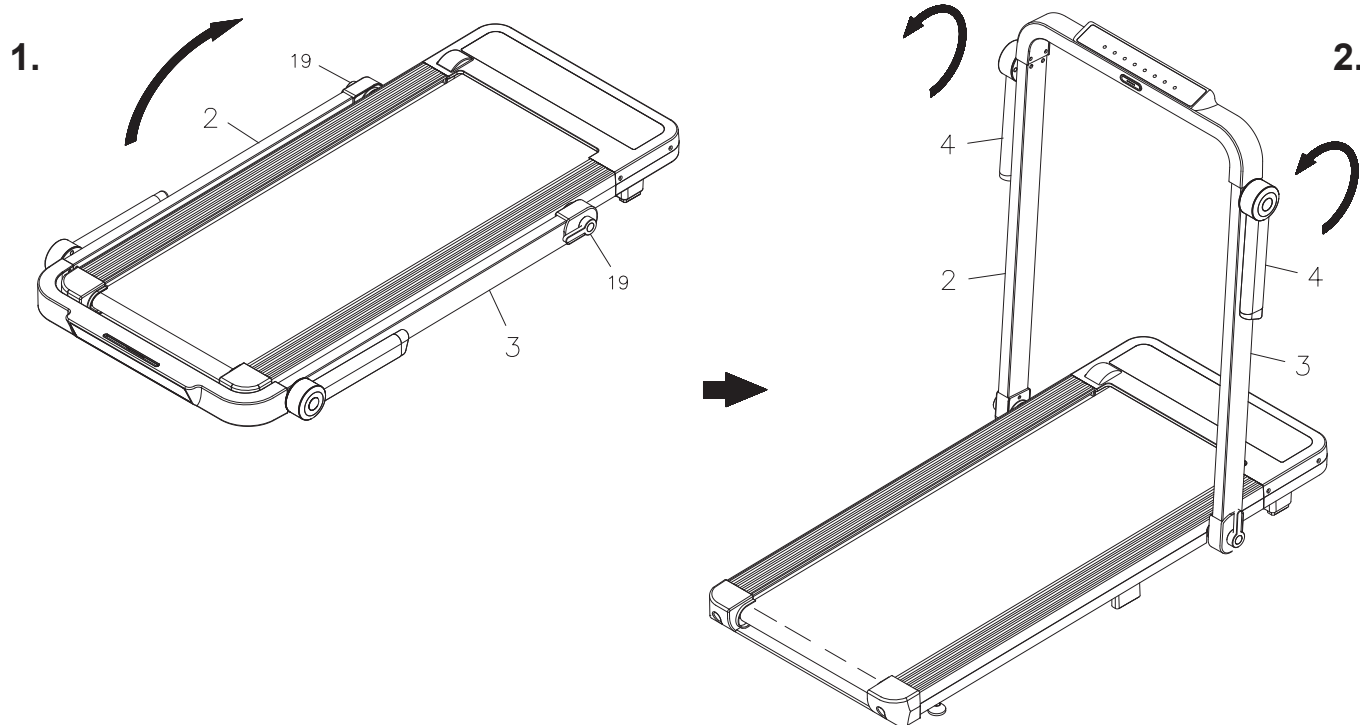

3. Your müüv Treadmill should look as shown in illustration 3. Insert the **SAFETY KEY(50)** into the notch at the front of the control panel.

NOTE: Attach the clothespin clip to your clothes in front of your chest or the nearest location. This ensures that the **SAFETY KEY(50)** is readily accessible during your workout.

4. The **TABLET HOLDER(28)** is optional and can be taken on and off as needed. To use the **TABLET HOLDER(28)**, insert it into the slot located at the back of the control panel. Place your tablet device on the **TABLET HOLDER(28)**.

NOTE:

1. Stop the treadmill when switching the functions between the walking mode and treadmill mode of the treadmill.
2. Keep fingers clear of all pinch points when folding and unfolding the treadmill.
3. Revert the above procedure to fold the treadmill for storage.

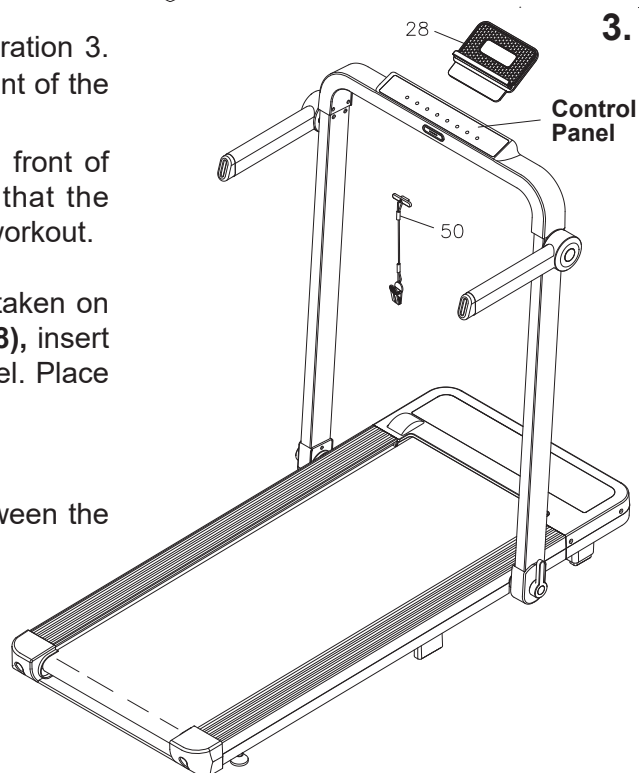

OPERATIONAL INSTRUCTIONS

müüv CONNECTION OPERATION

NOTE:

1. To fully operate your inStride Treadmill you will need to download the free müüv app.
2. You will need to enable bluetooth in your phone settings first.



müüv

Scan the QR Code to download the app.
See insert for details.

Enjoy ad-free music during workouts with
iHeartRADIO

Power on the inStride Treadmill. Open the müüv app and follow the process below to connect the treadmill to the müüv app. It will make your inStride Treadmill work with the müüv application and many others. For more details and information, go visit <https://müüv.fit>.

- 1** Tap on the Setting icon.

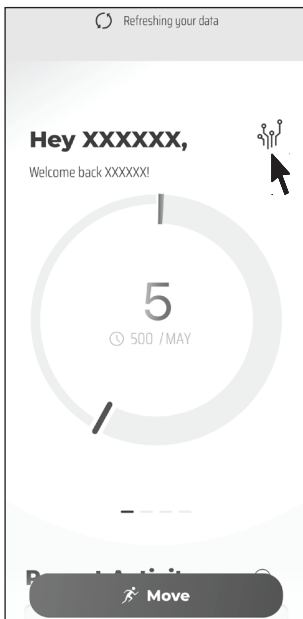

- 2** Tap on ALL SETTINGS.

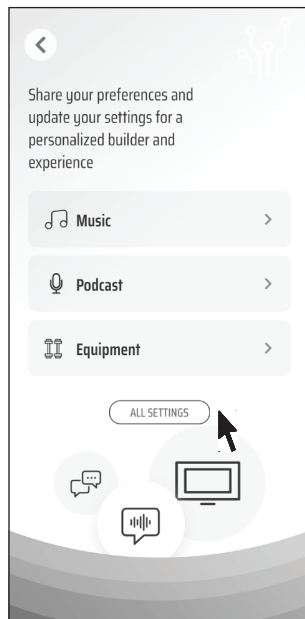

- 3** Tap on Connected Devices.

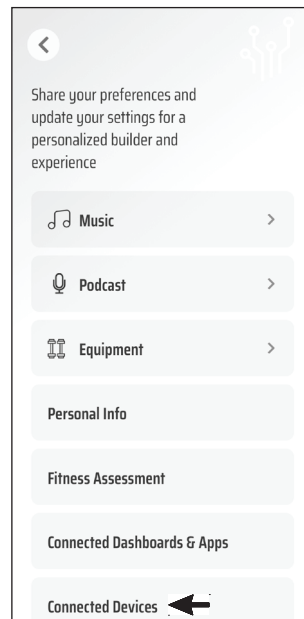

- 4** Tap on Connect next to the "TL9850/9851" to connect.

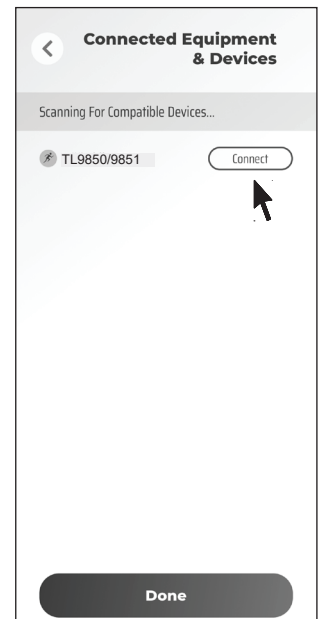

OPERATIONAL INSTRUCTIONS

USING THE FITNESS METER

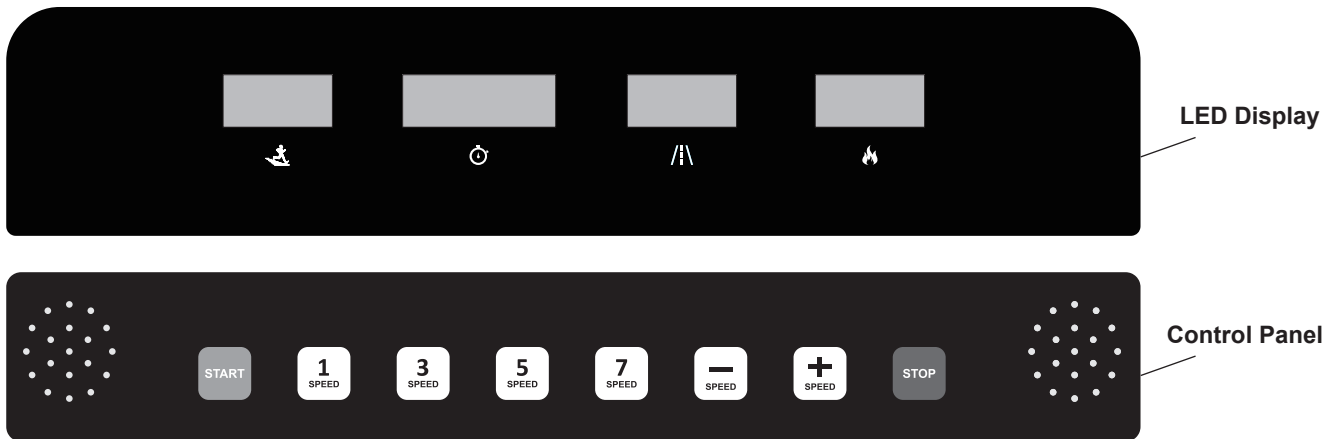

GUIDELINES FOR USE:

- Plug the **POWER CORD(51)** into the socket on the front of the **BASE FRAME(1)**, and plug the **POWER CORD(51)** into an electrical outlet with safety grounding. Turn on the power switch, the LED display will be fully displayed with a prompt sound.
- Place the **SAFETY KEY(50)** into the notch at the front of the control panel, and clip the clothespin to the clothes in front of your chest.
- The electronic control system is under safety monitoring at all times. If any abnormality is found, the running treadmill will stop in an emergency, and the LED display will display the error code.

FUNCTION BUTTONS:

START: Press to start running the treadmill.

STOP: Press to pause the treadmill and all function values will be kept. You can press the **START** button to continue the workout with these function values, or press the **STOP** button again to reset all functions to zero.

— (Minus): Press to decrease the **SPEED** when running the treadmill.

+ (Plus): Press to increase the **SPEED** when running the treadmill.

SPEED SHORTCUT BUTTONS:

There are four speed shortcut buttons of 1 mph, 3 mph, 5 mph, and 7 mph. When running the treadmill, if you select one of the preset speed value, the speed will start slowly and increase up to the selected speed.

OPERATIONAL INSTRUCTIONS

REMOTE CONTROL FUNCTIONS:

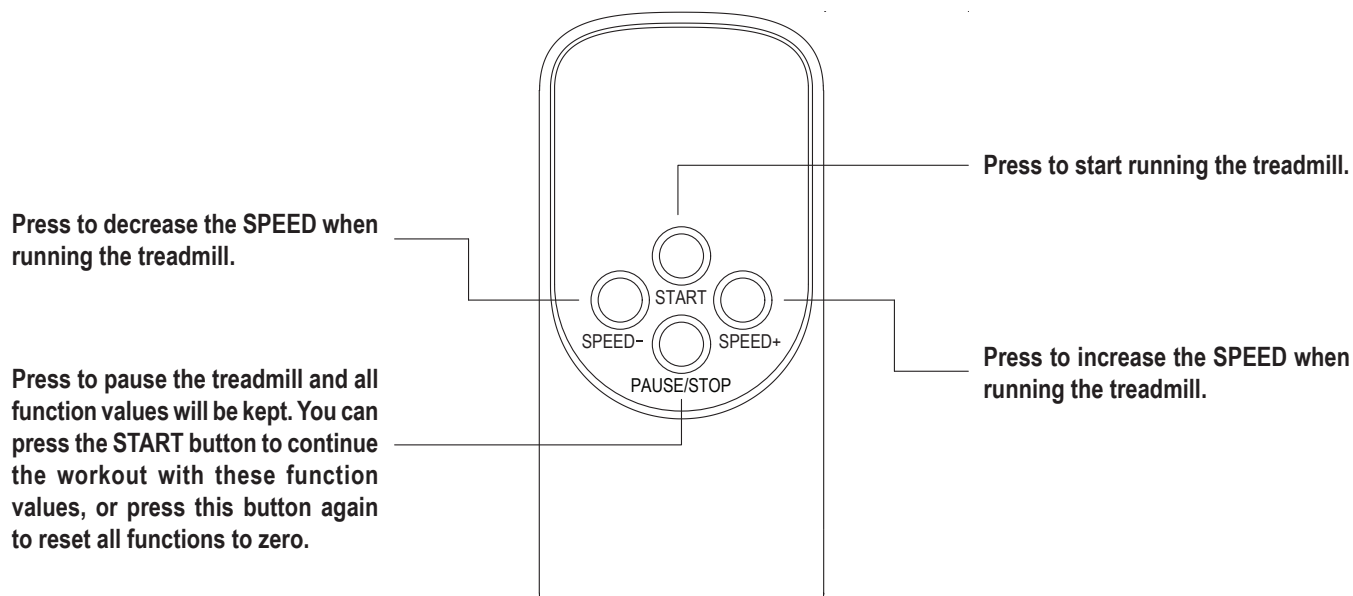

HOW TO INSTALL AND REPLACE BATTERIES:

1. Open the battery door on the back of the **REMOTE CONTROL(49)**.
2. The **REMOTE CONTROL(49)** operates with two AAA batteries (1.5V each), the batteries are not included. Refer to the illustration to install or replace the batteries.

- NOTE:**
1. Do not mix a new battery with an old battery.
 2. Use the same type of battery. Do not mix an alkaline battery with another type of battery.
 3. Rechargeable batteries are not recommended.
 4. **Ultimate disposal of battery should be handled according to all state and federal laws and regulations.**
 5. **Do not dispose of batteries in fire.**

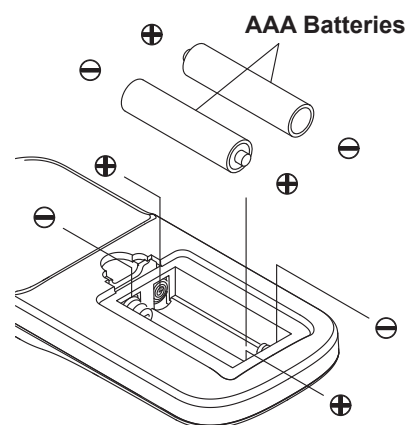

DISPLAY INSTRUCTIONS



Displays the current speed from zero to 7.5 miles per hour.



Displays the time during exercise from one second up to 99:59 minutes.



Displays the distance from zero to 99.9 miles.



Displays the calories consumption from zero to 999 Kcal.

NOTE: The calorie readout is an estimate for an average user. It should be used only as a comparison between workouts on this unit.

OPERATIONAL INSTRUCTIONS

OPERATION NOTES:

- When you press the **START** button to start running the treadmill, the **TIME** display window will count down the numbers “3 - 2 - 1” with a prompt sound, then start the treadmill from the speed 0.5 miles per hour.
- The maximum speed of the walking mode is 2.5 miles per hour. The maximum speed of the treadmill mode is 7.5 miles per hour.
- When the treadmill is running, you can turn off the power switch to shut down the treadmill in any time. This will not damage the treadmill.

ERROR CODE AND TROUBLESHOOTING

Error Code	Possible Cause	Corrective Action
E01	Software over current	Unplug the power cord and replug it, the main reason is overload.
E02	Hardware over current	Unplug the power cord and replug it, the main reason is overload.
E03	IPM module overheating	Turn off the power switch for 30 minutes then use normally, the main reason is overload.
E04	Under voltage protection	The input voltage of the power supply is too low or the control board is damaged. Check whether the voltage of the power supply is normal. If the voltage is normal, replace the control board.
E05	Over voltage protection	The power input voltage is too high or the control board is damaged. Check whether the voltage of the power supply is normal. If the voltage is normal, replace the control board.
E06	Motor out of phase protection	Check whether the motor wiring is normal. If normal, replace the control board or motor.
E07	Motor blocking protection	<ul style="list-style-type: none"> • Unplug the power cord and replug it, then use normally, the main reason is overload or motor/roller stuck. • Check whether the transmission parts are normal.
E08	Motor won't start	Motor/roller stuck, check whether the transmission parts are normal. Change the motor or control board as necessary.
E09	Motor over current protection	<ul style="list-style-type: none"> • Running for a long time with high resistance, lubricate the treadmill. • Change motor.
E10	Overload protection	<ul style="list-style-type: none"> • Running for a long time with high resistance, lubricate the treadmill. • Change motor. • Change control board (within the max. rated load).
E12	Communication problem of up-down control	<ul style="list-style-type: none"> • Check whether the upper and lower control communication cables are correctly connected. Or, replace the cables as necessary. • Check whether the communication interface of the upper controller is normal. Or change the upper controller as necessary. • Check whether the communication interface of the lower controller is normal. Or change the lower controller as necessary.
E20	The key board communication is abnormal	Check whether the key board communication interface is normal. Or replace the communication board as necessary.

OPERATIONAL INSTRUCTIONS

TREADMILL ADJUSTMENTS

When adjusted properly, the inStride Treadmill's **WALKING BELT(10)** will roll smoothly around the **WALKING BOARD(9)** and over the front and rear rollers without catching or rubbing. For the belt to run smoothly, there are a few points that need to be noted.

BELT ALIGNMENT

The **WALKING BELT(10)** must be in the center of the **WALKING BOARD(9)** to prevent it from rubbing against the **MOTOR COVER(11)**. If the belt rubs the **MOTOR COVER(11)**, it will be difficult to keep the belt moving and will eventually damage the edge of the belt. The treadmill has belt guides at the bottom of the treadmill frame that move the belt toward the center of the treadmill. However, the **REAR ROLLER(8)** must be properly aligned with the treadmill frame and **FRONT ROLLER(7)** if the belt is to remain centered on the treadmill. The bolts in the rear of the treadmill (one on the left and the other on the right) adjust the alignment of the **REAR ROLLER(8)** as well as the tension of the belt.

The belt will run to the side that has the loose rear bolt.

- Hint:**
- Visually check the **REAR ROLLER(8)** to make sure both the right side and the left side of the **REAR ROLLER(8)** are the same distance from the back edge of the treadmill. Using the 6mm ALLEN WRENCH, make adjustments by turning the bolts clockwise to tighten and counterclockwise to loosen.
 - When doing the adjustment and checking whether the belt is in the center, you can power on the treadmill and run it with speed 3 mph to check for 1 - 2 minutes.

BELT DRIFTING LEFT

Adjust by turning the left screw 1/4 turn **CLOCKWISE** and the right screw 1/4 turn **COUNTERCLOCKWISE**. Walk on the treadmill to check alignment. Repeat if needed.

BELT DRIFTING RIGHT

Adjust by turning the left screw 1/4 turn **COUNTERCLOCKWISE** and the right screw 1/4 turn **CLOCKWISE**. Walk on the treadmill to check alignment. Repeat if needed.

NOTE:

When you believe the **WALKING BELT(10)** is centered, use the treadmill for three (3) minutes to verify the **WALKING BELT(10)** won't drift to one side or the other. If the **WALKING BELT(10)** continues to drift, the floor may not be level. Rotate the treadmill 90 degrees or move the treadmill to another location.

BELT TENSION

The **WALKING BELT(10)** should be taut and not lying loosely on the treadmill **WALKING BOARD(9)**. If the belt is too loose, it will slip on the front roller and you will notice a jerky movement when you walk on the treadmill. If the belt is too tight, the edges of the belt will begin to curl and more effort will be required to move the belt. Excessive belt tension can also damage the bearings in the rollers. The bolts on the ends of the **MAIN FRAME(1)** (one on the left and the other on the right) adjust the **WALKING BELT(10)** tension as well as the **REAR ROLLER(8)** alignment.

BELT TOO LOOSE: Use the 6mm **ALLEN WRENCH** to tighten the bolts on the ends of the **MAIN FRAME(1)**. Tighten both bolts 1/4 turn clockwise at a time until the belt stops slipping on the **FRONT ROLLER(7)**.

BELT TOO TIGHT : Use the 6mm **ALLEN WRENCH** to loosen the bolts on the ends of the **MAIN FRAME(1)**. Loosen both bolts 1/2 turn counterclockwise at a time until the belt begins to slip on the **FRONT ROLLER(7)**. Then use the procedure above to tighten the belt to the proper tension.

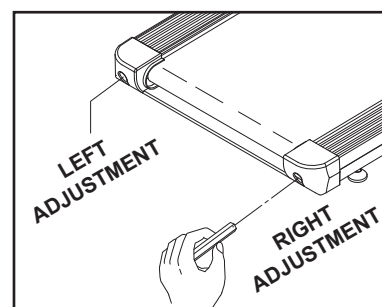

STORAGE

- To store the inStride Treadmill, simply keep it in a clean dry place.
- To move the inStride Treadmill, hold the back end of the inStride Treadmill and tilt the inStride Treadmill onto the wheels under the **LOWER MOTOR COVER(12)** at the front.
- The minimum folded dimensions of the inStride Treadmill are approximately 53.6 inches long x 22.3 inches wide x 9.1 inches tall. Please measure your inStride Treadmill if exact dimensions are needed.
- To avoid damage to the electronics, remove the batteries from the remote before storing the inStride Treadmill for one year or more.

MAINTENANCE

The safety and integrity designed into the inStride Treadmill can only be maintained when the inStride Treadmill is regularly examined for damage and wear. Special attention should be given to the following:

⚠ WARNING Always unplug the treadmill from the electrical outlet before cleaning or servicing the inStride Treadmill.

- Periodic cleaning will greatly prolong the life of the treadmill. Keep treadmill clean by dusting regularly. Be sure to clean the exposed part of the deck on either side of the walking belt and also the side rails. Wearing clean running shoes will reduce the build up of foreign material underneath the walking belt.
- Always make sure the **UPRIGHTS(2, 3)** are locked properly by the **FIXING LEVER(19)**.
- Verify that all nuts and bolts are present and properly tightened. Replace missing nuts and bolts. Tighten loose nuts and bolts.
- Verify that the **CAUTION LABEL(50)** is in place and easy to read. Call Stamina Products immediately at 1-800-375-7520 for a replacement **CAUTION LABEL(50)** if it is missing or damaged.
- It is the sole responsibility of the user/owner to ensure that regular maintenance is performed.
- Worn or damaged parts must be replaced immediately or the inStride Treadmill removed from service until repair is made.
- Only Stamina Products supplied components should be used to maintain/repair the inStride Treadmill.
- If the **WALKING BELT(10)** does not move easily, lubricate the **WALKING BOARD(9)** under the **WALKING BELT(10)** with silicone lubricant.

MAINTENANCE

HANDRAIL ADJUSTMENT

Over time the **HANDRAIL(4)** may loosen. You can remove the **ROUND PLUG(22)** from the **HANDRAIL COVER(23)**. Use the **ALLEN WRENCH(6mm)(53)** to tighten the **FLAT SOCKET HEAD BOLT(M10x1.45x30)(74)** which is located on the inside of the cover. The **HANDRAIL(4)** must be able to rotate, do not overtighten the bolt. Press the **ROUND PLUG(22)** back into the **HANDRAIL COVER(23)**.

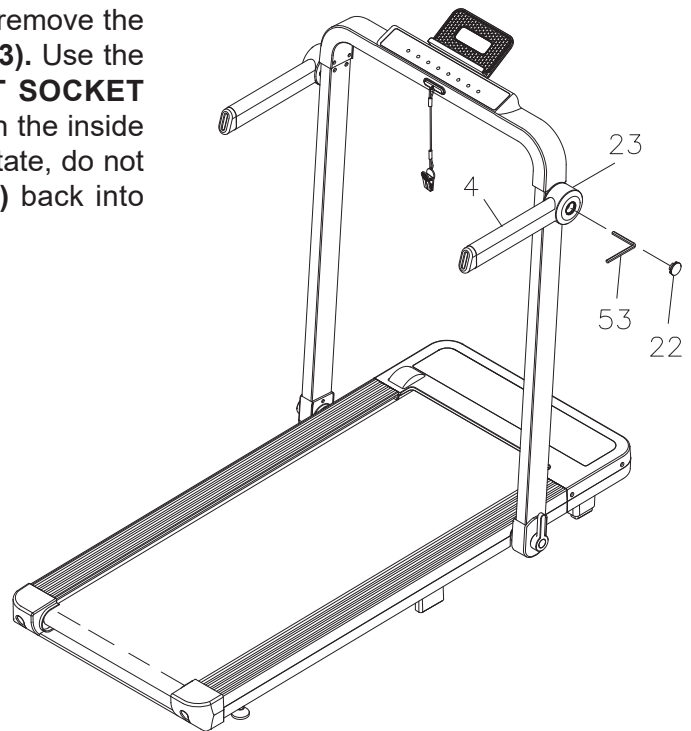

WALKING BELT AND BOARD LUBRICATION

If the **WALKING BELT(10)** does not move easily, or every 600 hours of use, lubricate the **WALKING BOARD(9)** with 100% silicone lubricant. Lift one side of the **WALKING BELT(10)**, apply approximately 20 ml of lubricant to the center of the **WALKING BOARD(9)**. Start the treadmill at the lowest speed to allow the lubricant to spread all over the **WALKING BOARD(9)**.

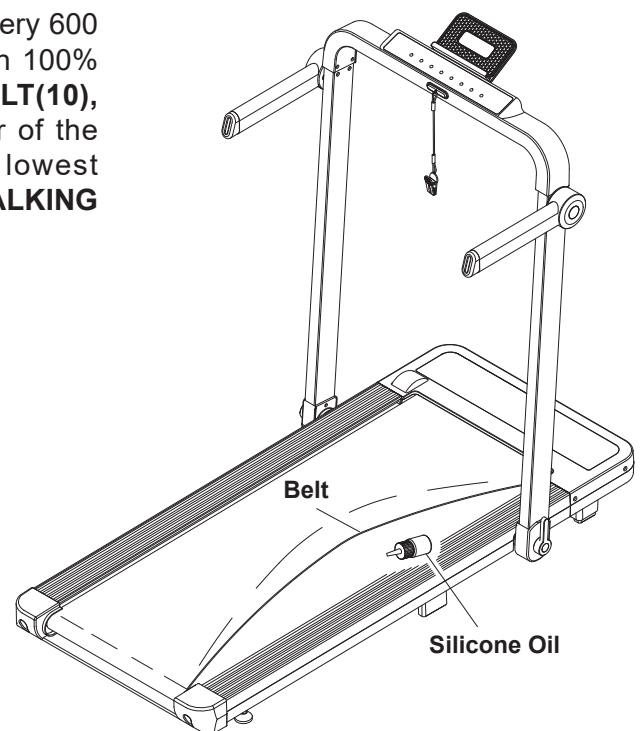

CONDITIONING GUIDELINES

How you begin your exercise program depends on your physical condition. If you have been inactive for several years or are severely overweight, start slowly and increase your workout time gradually. Increase your workout intensity gradually by monitoring your heart rate while you exercise.

Remember to follow these essentials:

- Have your doctor review your training and diet programs.
- Begin your training program slowly with realistic goals that have been set by you and your physician.
- Warm up before you exercise and cool down after you work out.
- Take your pulse periodically during your workout and strive to stay within a range of 60% (lower intensity) to 90% (higher intensity) of your maximum heart rate zone. Start at the lower intensity, and build up to higher intensity as you become more aerobically fit.
- If you feel dizzy or lightheaded you should slow down or stop exercising.

Initially you may only be able to exercise within your target zone for a few minutes; however, your aerobic capacity will improve over the next six to eight weeks. It is important to pace yourself while you exercise so you don't tire too quickly.

To determine if you are working out at the correct intensity, use a heart rate monitor or use the table below. For effective aerobic exercise, your heart rate should be maintained at a level between 60% and 90% of your maximum heart rate. If just starting an exercise program, work out at the low end of your target heart rate zone. As your aerobic capacity improves, gradually increase the intensity of your workout by increasing your heart rate.

Measure your heart rate periodically during your workout by stopping the exercise but continuing to move your legs or walk around. Place two or three fingers on your wrist and take a six second heartbeat count. Multiply the results by ten to find your heart rate. For example, if your six second heartbeat count is 14, your heart rate is 140 beats per minute. A six second count is used because your heart rate will drop rapidly when you stop exercising. Adjust the intensity of your exercise until your heart rate is at the proper level.

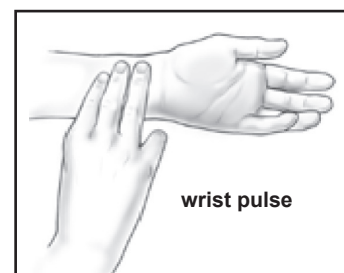

Target Heart Rate Zone Estimated by Age*

Age	Target Heart Rate Zone (55%-90% of Maximum Heart Rate)	Average Maximum Heart Rate 100%
20 years	110-180 beats per minute	200 beats per minute
25 years	107-175 beats per minute	195 beats per minute
30 years	105-171 beats per minute	190 beats per minute
35 years	102-166 beats per minute	185 beats per minute
40 years	99-162 beats per minute	180 beats per minute
45 years	97-157 beats per minute	175 beats per minute
50 years	94-153 beats per minute	170 beats per minute
55 years	91-148 beats per minute	165 beats per minute
60 years	88-144 beats per minute	160 beats per minute
65 years	85-139 beats per minute	155 beats per minute
70 years	83-135 beats per minute	150 beats per minute

* For cardiorespiratory training benefits, the American College of Sports Medicine recommends working out within a heart rate range of 55% to 90% of maximum heart rate. To predict the maximum heart rate, the following formula was used: $220 - \text{Age} = \text{predicted maximum heart rate}$

WARM-UP and COOL-DOWN

Warm-Up The purpose of warming up is to prepare your body for exercise and to minimize injuries. Warm up for two to five minutes before strength training or aerobic exercising. Perform activities that raise your heart rate and warm the working muscles. Activities may include brisk walking, jogging, jumping jacks, jump rope, and running in place.

Cool-Down The purpose of cooling down is to return the body to its normal, or near normal, resting state at the end of each exercise session. A proper cool-down slowly lowers your heart rate and allows blood to return to the heart. Your cool down should be completed after each strength training session.

PRODUCT PARTS DRAWING

FRONT

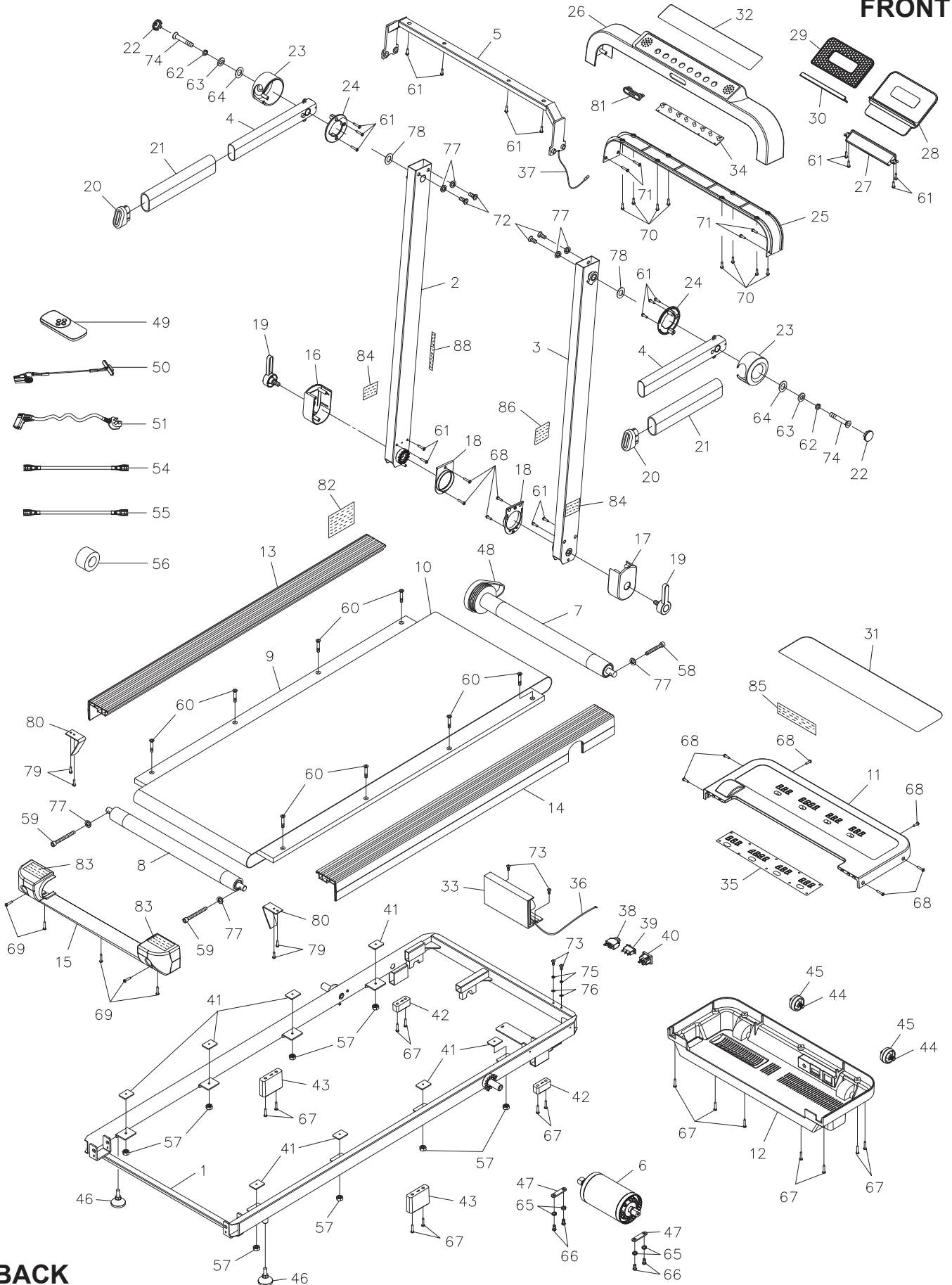

BACK

PARTS LIST

PART#	PART NAME	QTY
1	Main Frame	1
2	Left Upright	1
3	Right Upright	1
4	Handrail	2
5	Crossing Frame	1
6	Motor (1.0HP, 5A, 746w, brushless motor)	1
7	Front Roller w/ Flywheel	1
8	Rear Roller	1
9	Walking Board	1
10	Walking Belt	1
11	Motor Cover	1
12	Lower Motor Cover	1
13	Left Side Molding	1
14	Right Side Molding	1
15	Rear Cover	1
16	Left Upright Lower Cover	1
17	Right Upright Lower Cover	1
18	Upright Inner Support Plate	2
19	Fixing Lever	2
20	Handrail Cap	2
21	Foam Grip	2
22	Round Plug	2
23	Handrail Cover	2
24	Handrail Inner Cover	2
25	Lower Meter Cover	1
26	Meter Cover	1
27	Holder Support	1
28	Tablet Holder	1
29	Tablet Holder Pad	1
30	Tablet Bottom Support	1
31	Display Overlay	1
32	Control Panel	1
33	Motor Controller	1
34	Meter PCB	1
35	LED PCB	1
36	Power Wire	1
37	Meter Connecting Wire	1
38	Circuit Breaker	1
39	Power Switch	1
40	AC Inlet	1
41	Walking Board Bumper	8
42	Front Rubber Stand	2
43	Rear Rubber Stand	2
44	Wheel Shaft	2
45	Wheel	2
46	Stand	2
47	Motor Mounting Plate	2

PARTS LIST

PART#	PART NAME	QTY
48	V-Ribbed Belt	1
49	Remote Control	1
50	Safety Key	1
51	Power Cord	1
53	Allen Wrench (6mm)	1
54	Extension Wire (blue color)	1
55	Extension Wire (brown color)	1
56	Magnetic Ring	1
57	Nylock Nut (M6 x 1)	8
58	Bolt, Socket Head (M8 x 1.25 x 45mm)	1
59	Bolt, Socket Head (M8 x 1.25 x 60mm)	2
60	Bolt, Flat Socket Head (M6 x 1 x 30mm)	8
61	Screw, Round Head (M4.2 x 13mm)	18
62	Lock Washer (M10)	2
63	Washer (ø10.5 x ø25 x 4mm thick)	2
64	Nylon Washer (ø16.2 x ø24 x 3mm thick)	2
65	Lock Washer (M6)	4
66	Bolt, Round Head (M6 x 1 x 15mm)	4
67	Screw, Round Head Self-Tapping (ST4.2 x 19mm)	15
68	Screw, Flat Head Self-Tapping (ST4.2 x 19mm)	10
69	Screw, Round Head Self-Tapping (ST4.2 x 15mm)	5
70	Screw, Flat Head (ST4.2 x 19mm)	8
71	Screw, Flat Head (ST4.2 x 28mm)	4
72	Bolt, Button Head (M8 x 1.25 x 15mm)	4
73	Screw, Round Head (M5 x 0.8 x 8mm)	4
74	Bolt, Flat Socket Head (M10 x 1.45 x 30mm, with threadlocker)	2
75	Lock Washer (M5)	2
76	Internal Tooth Lock Washer (M5)	2
77	Internal Tooth Lock Washer (M8)	7
78	Wave Washer (ø15 x ø28)	2
79	Screw, Round Head Self-Tapping (ST4.2 x 12mm)	4
80	Belt Guider	2
81	Safety Key Base	1
82	Warning Label 1	1
83	Warning Label 2	2
84	Fixing Lever Warning Label	2
85	Intertek ETL Label	1
86	Serial Decal	1
87	Owner's Manual	1
88	Warning Label 3	1

LIMITED WARRANTY

MODEL 45-9850, 45-9851

WARRANTY

Stamina Products, Inc. ("Stamina") warrants to the original purchaser that this product will be free from defects in materials and workmanship that arise under normal use, service, proper assembly and proper operation in accordance with product warnings/instructions for a period of 90 days on the parts and three years on the frame from the date of the original purchase from an authorized retailer. **THIS WARRANTY SHALL NOT APPLY TO ANY PRODUCT WHICH HAS BEEN SUBJECT TO COMMERCIAL USE, ABUSE, MISUSE, ALTERATION OF ANY KIND OR TO ANY DEFECT OR CHANGE CAUSED BY IMPROPER ASSEMBLY, REPAIR, REPLACEMENT, SUBSTITUTION OR USE WITH PARTS NOT PROVIDED BY STAMINA.** Commercial use includes use of product in athletic clubs, health clubs, spas, gyms, and all other public or semipublic facilities whether or not the product's use is in furtherance of a profit making enterprise, and all other use which is not for personal purposes.

To implement this limited warranty, send a written notice stating your name, date, and place of purchase and a brief description of the defect along with your receipt to Stamina Products, Inc. 2040 N Alliance Ave, Springfield, Missouri, USA, MO 65803, or email us at customer.care@staminaproducts.com, or call us at 1-800-375-7520. If the defect is covered under this limited warranty, you will be requested to return the product or part to us for free repair or replacement at our option.

NO ACTION FOR BREACH OF THIS LIMITED WARRANTY MAY BE COMMENCED MORE THAN ONE (1) YEAR AFTER THE DATE THE ALLEGED BREACH WAS OR SHOULD HAVE BEEN DISCOVERED. NO ACTION FOR BREACH OF ANY IMPLIED WARRANTY (INCLUDING MERCHANTABILITY AND FITNESS FOR A PARTICULAR PURPOSE) MAY BE COMMENCED MORE THAN ONE (1) YEAR AFTER DELIVERY OF THE PRODUCT TO THE PURCHASER. These warranties are not transferable. **IF ANY PART OF THE PRODUCT IS NOT IN COMPLIANCE WITH THIS LIMITED WARRANTY OR ANY IMPLIED WARRANTY, THE REMEDY OF REPAIR OR REPLACEMENT IS THE EXCLUSIVE REMEDY.** If any claim is made under this limited warranty or any implied warranty, Stamina reserves the right to require the product to be returned for inspection, at the purchaser's expense, to Stamina's premises in Springfield, Missouri. Return of the enclosed warranty registration card is not required for warranty coverage, but is merely a way of establishing the date and place of purchase.

Stamina **SHALL NOT BE LIABLE FOR THE LOSS OF USE OF ANY PRODUCT, LOSS OF TIME, INCONVENIENCE, COMMERCIAL LOSS OR ANY OTHER INDIRECT, CONSEQUENTIAL, SPECIAL OR INCIDENTAL DAMAGES DUE TO BREACH OF THE ABOVE WARRANTY OR ANY IMPLIED WARRANTY.**

THIS LIMITED WARRANTY IS THE ONLY EXPRESS WARRANTY. NO ORAL OR WRITTEN INFORMATION GIVEN BY STAMINA, ITS AGENTS OR EMPLOYEES, SHALL CREATE A WARRANTY OR IN ANY WAY INCREASE THE SCOPE OF THIS WARRANTY. This warranty gives you specific legal rights, and you may also have other legal rights which vary from state to state. **ANY OTHER RIGHT WHICH YOU MAY HAVE, INCLUDING ANY IMPLIED WARRANTY OF MERCHANTABILITY OR FITNESS FOR A PARTICULAR PURPOSE, IS LIMITED IN DURATION TO THE DURATION OF THIS WARRANTY.**

The laws in some states affect the disclaimer or limitation of implied warranties and consequential and incidental damages. If any such law is found applicable, the foregoing disclaimers and limitations of and on implied warranties and consequential and incidental damages shall be deemed to be modified to the extent necessary to comply with applicable law.

TO CONTACT CUSTOMER CARE

For your convenience, Stamina's customer care representatives can be reached by email at customer.care@staminaproducts.com or by phone at 1-800-375-7520 (in the U.S.). Our customer care representatives are available Monday through Thursday from 7:30 a.m. until 5:00 p.m., and Friday 8:00 a.m. until 3 p.m. Central Time.



**ONLINE
CUSTOMER CARE**
customer.care@staminaproducts.com
www.staminaproducts.com



**TELEPHONE
CUSTOMER CARE**
Tel: 1 (800) 375-7520



**FAX
CUSTOMER CARE**
Fax: (417) 889-8064



MAIL
STAMINA PRODUCTS, INC.
ATTN: Customer Care
2040 N Alliance Ave, Springfield, MO 65803

Would you like to receive email information or special offers from Stamina Products? Register at contact.staminaproducts.com

TO REGISTER YOUR PRODUCT

To enact your warranty, please register your product by going to register.staminaproducts.com. Please have your product model number (printed on the cover of this owner's manual) and the serial number (printed on the black and white sticker on your product) ready.

If you don't have internet access, you can call customer care at 1-800-375-7520, or fill out and mail the product registration form below to Stamina Products, Inc.; 2040 N Alliance Ave, Springfield, MO 65803.

PRODUCT REGISTRATION FORM		Stamina Products, Inc. 2040 N Alliance Ave, Springfield, MO 65803	
Model Number:		Serial Number:	
Product Name:			
Place Purchased:			
Date of Purchase:		Purchase Price:	
First Name:		Last Name:	
City:	State:	Phone #: ()	Zip Code:
Email Address:		Phone #: ()	
Would you like to receive email information or special offers from Stamina Products?* <input type="checkbox"/> Yes <input type="checkbox"/> No *If yes, be sure your email address is included above.			



Detach and Mail or Fax the Form Above



TO ORDER PARTS

If there are missing or damaged parts, you can go to parts.staminaproducts.com and order those parts. If you have questions, please contact customer care. Do not return the product. To order parts by mail, fill out the sheet below and fax it to 417-889-8064. The part will be mailed to your address.



Detach and Mail or Fax the Form Below



PARTS ORDER FORM		Stamina Products, Inc. 2040 N Alliance Ave, Springfield, MO 65803	
Mr./Ms:			
Address:		Apt. #:	
City:	State:	Zip Code:	
IMPORTANT : We require your phone number to process the order!			
Phone #: ()		Work Phone #: ()	
Date of Purchase:			
Model #:			
Purchased From:			

**IMPORTANT: Before filling out the portion below, make sure you have the correct information.
Refer to the parts list to make sure you're ordering the right parts!**

PART #	DESCRIPTION	QUANTITY
EXAMPLE: 1	Rear Unit Assembly	1