

# Pilates Home Studio<sup>®</sup>

by AeroPilates<sup>®</sup>

## Owner's Manual

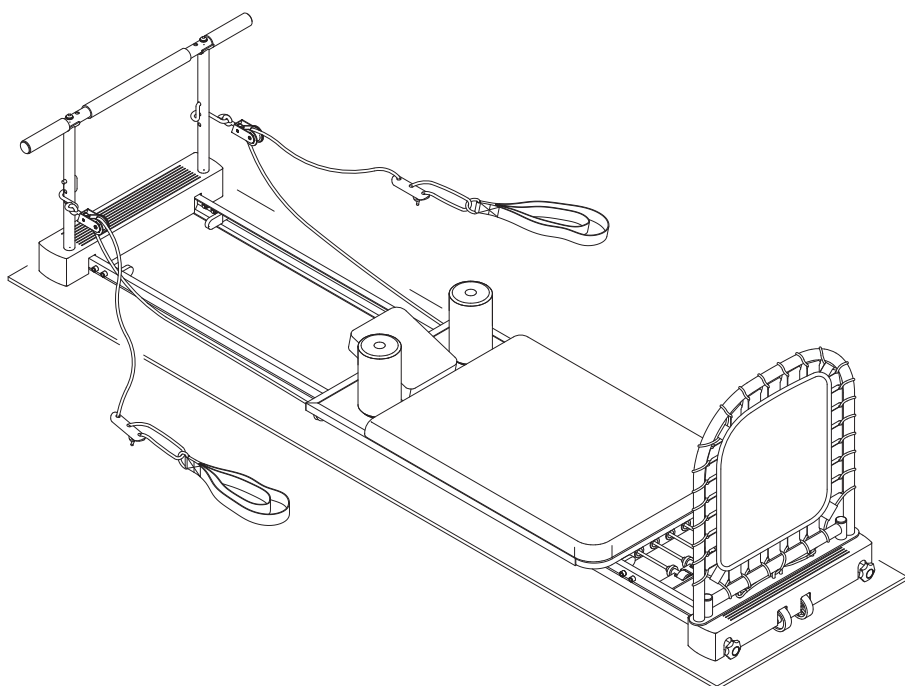

Product May Vary Slightly From Pictured.

### CAUTION:

Weight on this product should not exceed 350 lbs.

This Product is Distributed Exclusively by



2040 N Alliance Ave, Springfield, MO 65803

Customer Care

1 (800) 375-7520

[www.staminaproducts.com](http://www.staminaproducts.com)

### ⚠ WARNING

- Exercise can present a health risk. Consult a physician before beginning any exercise program with this equipment. If you feel faint or dizzy, immediately discontinue use.
- Serious bodily injury can occur if this equipment is not assembled and used in accordance with the owner's manual.
- Follow all safety instructions in this owner's manual.

When calling for parts or service, please specify the following numbers:

**Model#: 55-5107**

**S/N: \_\_\_\_\_**

United States and/or International patents apply and/or are pending. See [www.staminaproducts.com](http://www.staminaproducts.com) for details.

**STAMINA PRODUCTS  
MADE IN CHINA**

© 2023 Stamina Products, Inc.  
2023, 10



ACCESS DIGITAL VERSIONS  
OF YOUR WORKOUT DVDS,  
PLUS GET AN ADDITIONAL  
FREE, ONLINE WORKOUT!

## How to Access Your Videos

1. Go to [video.staminaproducts.com](http://video.staminaproducts.com)
2. Click 
3. Enter your product VIDEO CODE

*Your **video code** is the model number + serial number. This info can be found on the serial decal.*

*\*EXAMPLE ONLY. USE MODEL NUMBER + SERIAL NUMBER FROM THE DECAL ON YOUR PRODUCT.*



Coupon Code\*

15-033601JAN351450

 REDEEM

*Digital product only. No physical DVD will be shipped.*

## TABLE OF CONTENTS

Safety Instructions .....	3	Maintenance .....	18
Before You Begin .....	5	Conditioning Guidelines .....	19
Equipment Warning, Caution & Notice Labels ...	6	Warm-Up and Cool-Down .....	20
Hardware Identification Chart .....	7	Warranty .....	21
Assembly Instructions .....	8	Product Parts Drawing .....	22
Operational Instructions .....	12	Parts List .....	23
Storage .....	18	Fax/Mail Ordering Form .....	25

## SAFETY INSTRUCTIONS

**⚠ WARNING** Cancer and Reproductive Harm [www.P65Warnings.ca.gov](http://www.P65Warnings.ca.gov)

**⚠ WARNING** Consult your physician before starting this or any exercise program. This is especially important if you are over the age of 35, have never exercised before, are pregnant, or suffer from any health problem. This product is for home use only. Do not use in institutional or commercial applications. Failure to follow all warnings and instructions could result in serious injury or death.

**⚠ WARNING** The Tension Cords(8, 9, and 10) and Bungee Cord(52) contain natural rubber latex which may cause allergic reactions.

**⚠ WARNING** To reduce the risk of serious injury, read the following Safety Instructions before using the Pilates Home Studio.

- The Pilates Home Studio should only be used after a thorough review of the Owner's Manual by all exercisers and saved for future reference.
- Make sure that the product is properly assembled and tightened before use.
- We recommend that two people be available for assembly of this product.
- Keep children and pets away from the Pilates Home Studio at all times. This product is for adult use only.
- When exercising on this product, do not exercise at an intensity that causes the product itself to move. This could result in damage to your joints and to the product.
- It is recommended that you place this product on an equipment mat.
- Set up and operate the Pilates Home Studio on a solid level surface. Do not position the product on loose or uneven surfaces.
- Make sure that adequate space is available for access to and around the product.
- When folding or unfolding the Pilates Home Studio, keep all children away from the Pilates Home Studio and make sure your hands are clear of any folding or pinch point.
- Before using, always inspect the product for worn parts that should be replaced or loose parts that should be tightened.
- Always choose the workout which best fits your physical strength and flexibility level. Know your limits and train within them.
- Do not wear loose clothing while using the Pilates Home Studio.
- Always wear proper footwear such as running, walking, or cross training shoes.
- Be careful to maintain your balance while assembling, mounting, using and dismounting the Pilates Home Studio. Loss of balance may result in a fall or serious bodily injury.
- The Pilates Home Studio should not be used by persons weighing over 350 pounds.
- The Pilates Home Studio is for consumer use only. It is not for use in public or semipublic facilities.

**EXTEND YOUR PARTS WARRANTY TO 180 DAYS FROM THE DATE OF PURCHASE. REGISTER YOUR PRODUCT.**



**NEED HELP?  
CONTACT US FIRST  
1 (800) 375-7520  
customer.care@staminaproducts.com**

Hi! From all of us here at Stamina Products, thank you for your purchase. We know that you have big fitness goals in mind and we are here to help you along. Call us, email us, or send us a message on Facebook. Be sure to contact us if you have any questions on your new product. We look forward to hearing from you!

With your body in mind,  
***Stamina Customer Care***

**To enact your extended warranty and to help us better serve you, please go online and register your new product.**

**register.staminaproducts.com**

It is quick and easy to register online, but if you're a little old school or just need a reason to raise that little flag on your mailbox, fill out the info on the last page of this manual and mail it in.



**ONLINE**

customer.care@staminaproducts.com  
www.staminaproducts.com



**TELEPHONE**

1 (800) 375-7520



**FAX**

(417) 889-8064



**MAIL**

Stamina Products, Inc.  
ATTN: Customer Care  
2040 N Alliance Ave  
Springfield, MO 65803

 facebook.com/StaminaProducts  
facebook.com/AeroPilates

**CUSTOMER CARE HOURS:**  
Monday-Thursday, 7:30 AM-5:00 PM, Central Time  
Friday, 8:00 AM-3:00 PM, Central Time

## BEFORE YOU BEGIN

Thank you for choosing the Pilates Home Studio. We take great pride in this quality product and hope it will provide many hours of quality exercise to make you feel better, look better, and enjoy life to its fullest.

It's a proven fact that a regular exercise program can improve your physical and mental health. Too often, our busy lifestyles limit our time and opportunity to exercise. The Pilates Home Studio provides a convenient and simple method to begin your journey of getting your body in shape and achieving a happier and healthier lifestyle.

Before reading further, please review the drawing below and familiarize yourself with the parts that are labeled. Locate the serial decal on the product and write the serial number on the cover of the manual in the space provided. See the next page for an image of the serial decal. Model number and serial number are required when

calling for assistance.

Read this manual carefully before using the Pilates Home Studio.

Providing you with a quality product is Stamina's top priority. However, sometimes there could be a missing or incorrectly sized part. If you have any questions or problems with the parts included with your Pilates Home Studio, please do not return the product. Contact us **FIRST!**

If a part is missing or defective, please contact Customer Care for assistance. Call us toll free at 1-800-375-7520 (in the U.S.) or live chat on [staminaproducts.com](http://staminaproducts.com). Our Customer Care Staff is available to assist you from 7:30 A.M. to 5:00 P.M. (Central Time) Monday through Thursday and 8:00 A.M. to 3:00 P.M. (Central Time) on Friday.

Be sure to have the name and model number of the product available when you contact us.

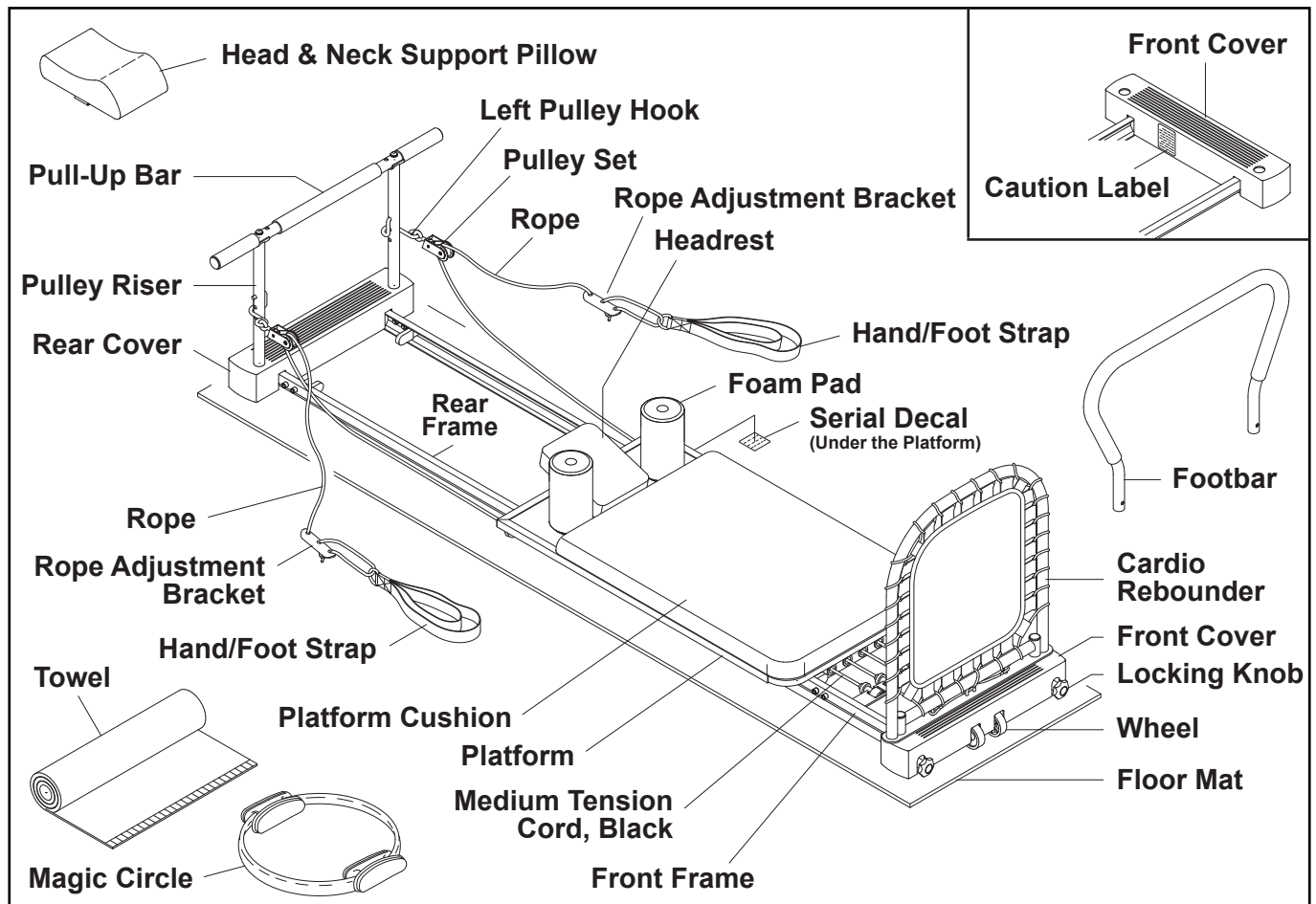

THE FOLLOWING TOOLS ARE INCLUDED FOR ASSEMBLY:

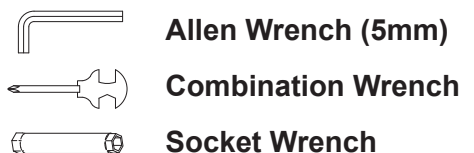

## EQUIPMENT WARNING, CAUTION & NOTICE LABELS

This chart is provided to help identify the warning, caution, and notice labels on the Pilates Home Studio. Please take a moment to familiarize yourself with all of the warning, caution, and notice labels.

### CAUTION LABEL(62)



### PINCH POINT CAUTION LABEL(18)



### SERIAL DECAL(63)



To best serve you, our Customer Care Representatives will need your serial number. For quick access, write in your serial number on the cover of the manual.





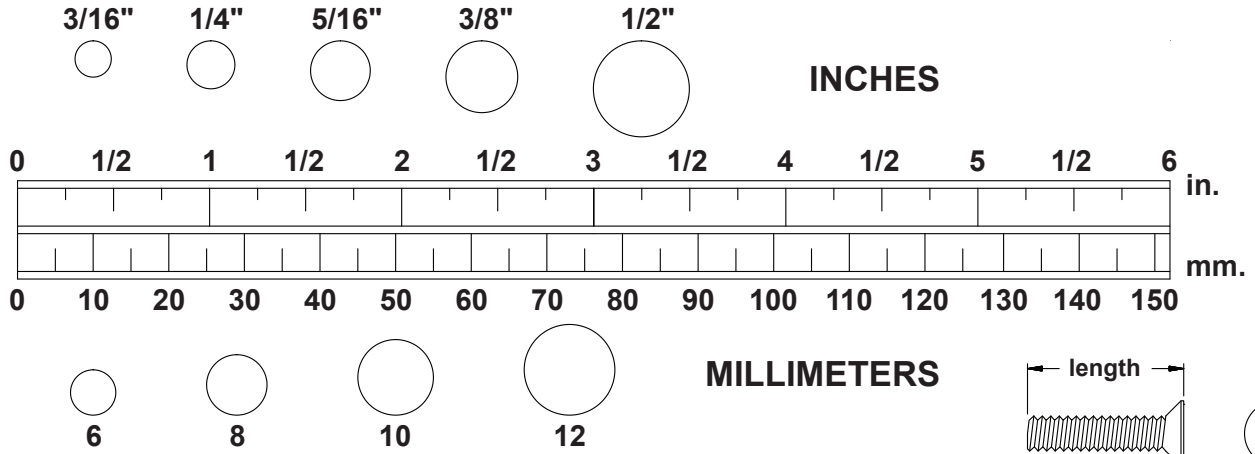

# HARDWARE IDENTIFICATION CHART

This chart is provided to help identify the hardware used in the assembly process. Place the washers or the ends of the bolts or screws on the circles to check for the correct diameter. Use the small scale to check the length of the bolts and screws.

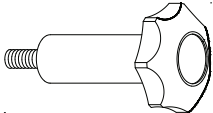
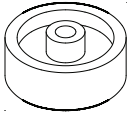

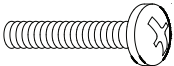
**NOTICE:** The length of all bolts and screws, except those with flat heads, is measured from below the head to the end of the bolt or screw. Flat head bolts and screws are measured from the top of the head to the end of the bolt or screw.

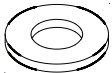
After unpacking the unit, open the hardware bag and make sure that you have all the following items. Some hardware may be already attached to the part.

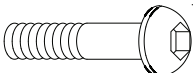
	Part Number and Description	Qty
	26 Locking Knob	4
	27 Wheel	2
	31 Rubber Foot	4
	38 Screw, Round Head (M5 x 0.8 x 35mm)	4
	42 Nylock Nut (M8 x 1.25)	2
	47 Washer (M8)	6
	57 Arc Washer (M8)	2
	58 Bolt, Button Head (M8 x 1.25 x 42mm)	2

## ASSEMBLY INSTRUCTIONS

Place all parts from the box in a cleared area and position them on the floor in front of you. Remove all packing materials from your area and place them back into the box. Do not dispose of the packing materials until assembly is completed. Read each step carefully before beginning. If you are missing a part, please go to [staminaproducts.com](http://staminaproducts.com) under the Customer Care section and order the part needed, e-mail us at [customer.care@staminaproducts.com](mailto:customer.care@staminaproducts.com), or call us toll free at 1-800-375-7520 (in the U.S.). Our Customer Care Staff is available to assist you from 7:30 A.M. to 5:00 P.M. (Central Time) Monday through Thursday and 8:00 A.M. to 3:00 P.M. (Central Time) on Friday.

**Some product parts are fit tested at the factory to ensure proper fit and alignment. Marks in the paint may be noticeable, but are not an indication of damage.**

### STEP 1

Remove your Pilates Home Studio from its packaging, placing the product on its side with the **LOCKING PIN(28)** side upward. Remove the **LOCKING PIN(28)** and unfold the **MAIN FRAME ASSEMBLY** separating the half that has the attached **LOCKING PIN(28)**. When completed, the frame should form a "V" with the frame ends separated approximately three feet.

### STEP 2

Attach the four **RUBBER FEET(31)** to the **FRONT FRAME(1)** and **REAR FRAME(2)** with **ROUND HEAD SCREWS(M5x0.8x35mm)(38)**. The **ROUND HEAD SCREWS(M5x0.8x35mm)(38)** are already in the **RUBBER FEET(31)**. Attach the **WHEELS(27)** to the **FRONT FRAME(1)** with **WASHERS (M8)(47)** and **NYLOCK NUTS(M8x1.25)(42)**.

### STEP 3

Unfold your Pilates Home Studio to a flat position by moving the **FRONT FRAME(1)** away from the platform end of the **REAR FRAME(2)** in a clockwise position until fully extended. Lower the Pilates Home Studio so all four **RUBBER FEET(31)** are flat on the floor.

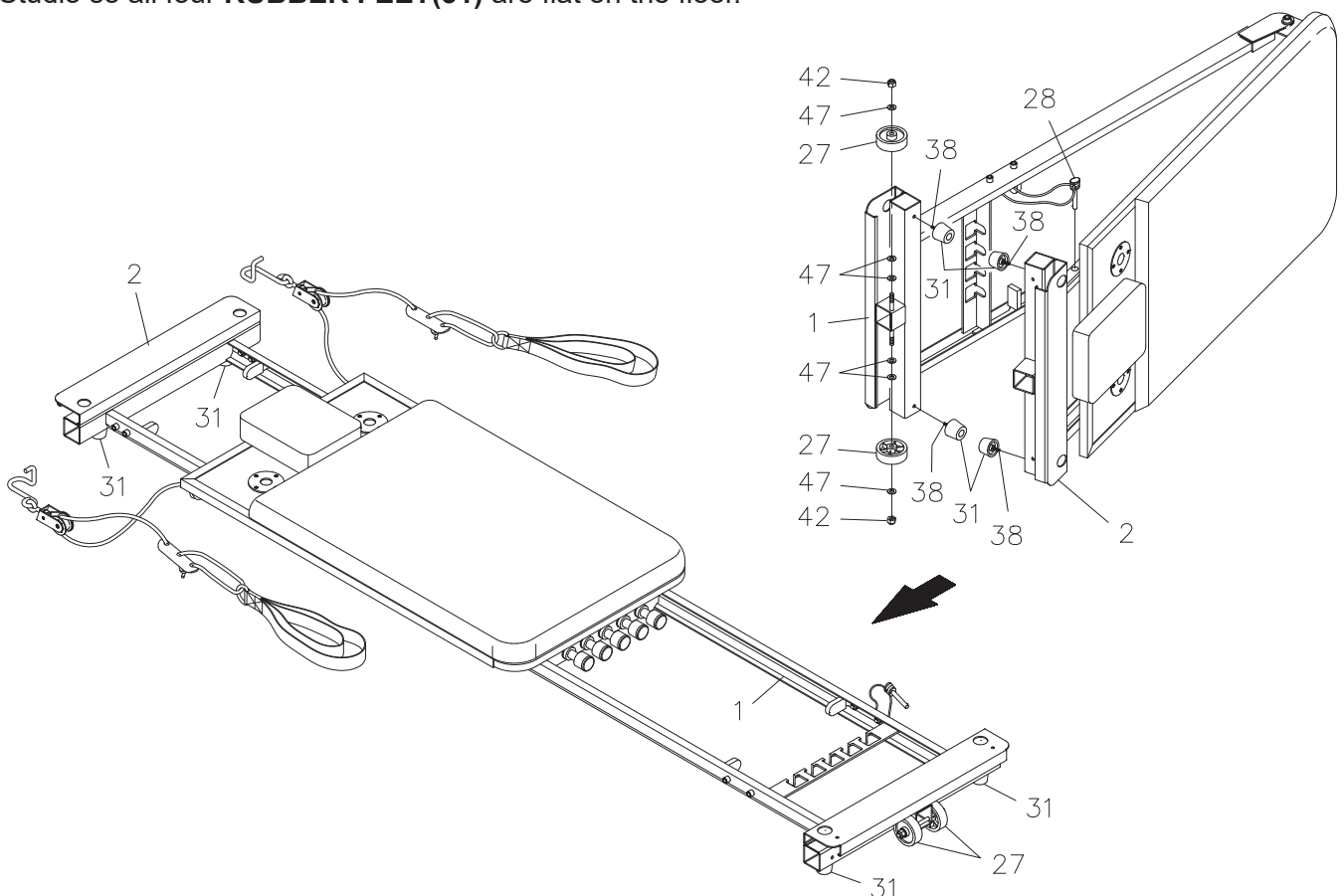



## ASSEMBLY INSTRUCTIONS

### STEP 4

Remove the paper covering from the foam tape inside the **FRONT COVER(3)**. Place the **FRONT COVER(3)** over the **FRONT FRAME(1)** and press the cover securely into place.

### STEP 5

Make sure that the threaded holes in the **FOOTBAR(5)** are facing toward the end of the Pilates Home Studio as shown in the illustration. Insert the **FOOTBAR(5)** into the mounting holes located in the **FRONT COVER(3)** and **FRONT FRAME(1)**. Insert the **FOOTBAR(5)** all the way to the bottom and lock it in place with the **LOCKING KNOBS(26)**.

**NOTE:** You can choose to insert the **CARDIO REBOUNDER(50)** into the **FRONT FRAME(1)** and lock in position with the **LOCKING KNOBS(26)**. Refer to the inset drawing.

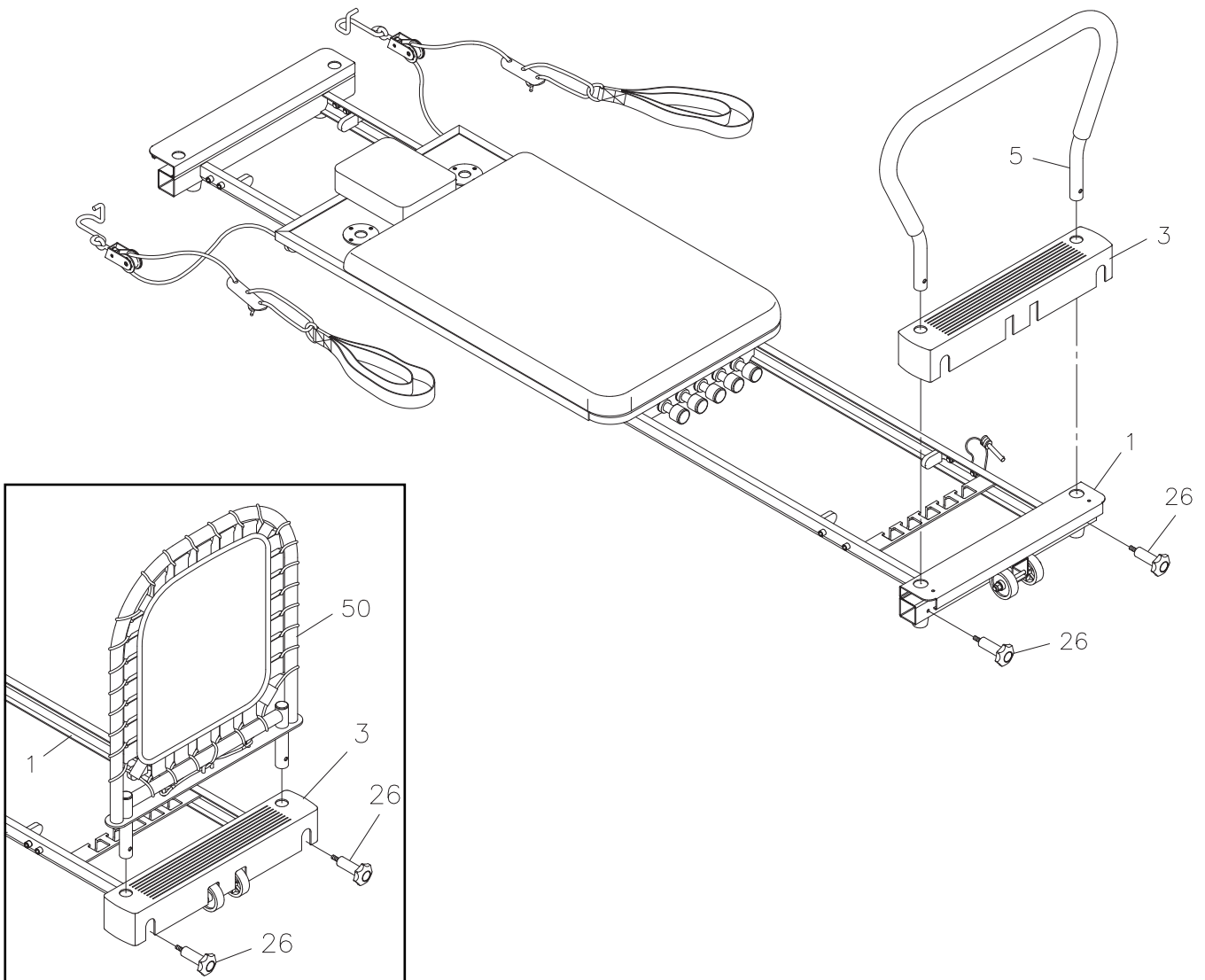

## ASSEMBLY INSTRUCTIONS

### STEP 6

Remove the paper covering from the foam tape inside the **REAR COVER(4)**. Place the **REAR COVER(4)** over the end of the **REAR FRAME(2)**. Press the cover securely in place.

### STEP 7

Insert the **PULLEY RISERS(25)** into the mounting holes in the **REAR COVER(4)** and **REAR FRAME(2)**. Insert the **PULLEY RISERS(25)** all the way to the bottom. Align the threaded holes in the **PULLEY RISERS(25)** with the holes in the **REAR FRAME(2)** and secure with the **LOCKING KNOBS(26)**, but don't tighten the knobs. Attach the **PULL-UP BAR(59)** to the **PULLEY RISERS(25)** with **BUTTON HEAD BOLTS(M8x1.25x42mm)(58)** and **ARC WASHERS(M8)(57)**. Tighten the **LOCKING KNOBS(26)**.

### STEP 8

Refer to the detail drawing below showing an enlarged view of the left **PULLEY RISER(25)** and the **LEFT PULLEY HOOK(23)**. With the pulley facing down, insert the **LEFT PULLEY HOOK(23)** into the left **PULLEY RISER(25)** from the inside as shown. Swing the pulley forward as shown and the **LEFT PULLEY HOOK(23)** will be in position for use. Use the same procedure to install the **RIGHT PULLEY HOOK(24)** on the right **PULLEY RISER(25)**.

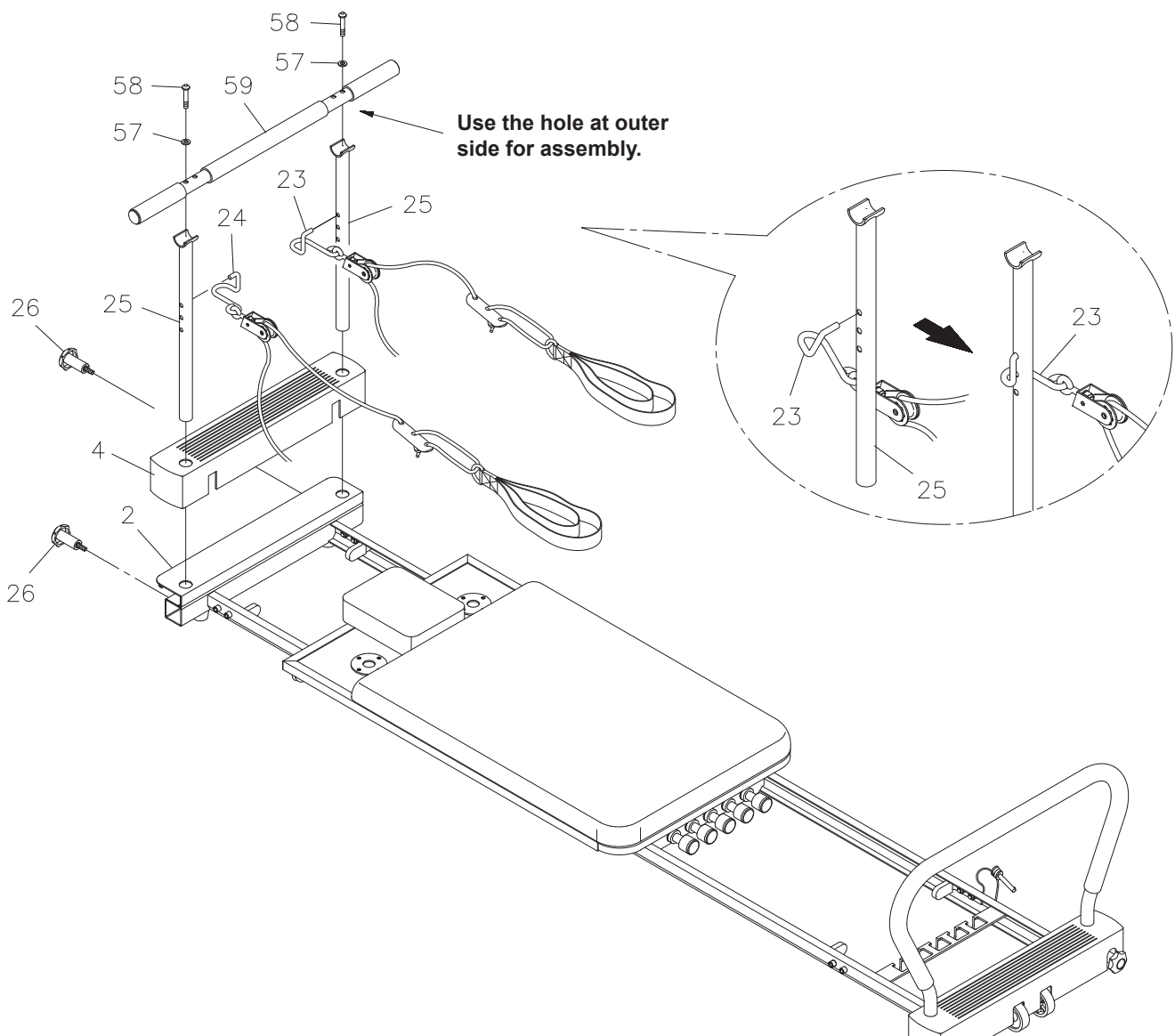

## ASSEMBLY INSTRUCTIONS

### STEP 9

Insert the **FOAM PAD ASSEMBLIES(16)** into the holes located on the **PLATFORM(7)**. Place the **HAND/ FOOT STRAPS(20)** onto the **FOAM PAD ASSEMBLIES(16)** for storage.

### STEP 10

Place the Pilates Home Studio onto the **FLOOR MAT(72)** as shown in the illustration. Refer to the inset drawing. To prevent the **PLATFORM(7)** from moving while placing the Pilates Home Studio onto the **FLOOR MAT(72)**, attach one of the **TENSION CORDS(8, 9, 10)** in the slot on the **FRONT FRAME(1)**.

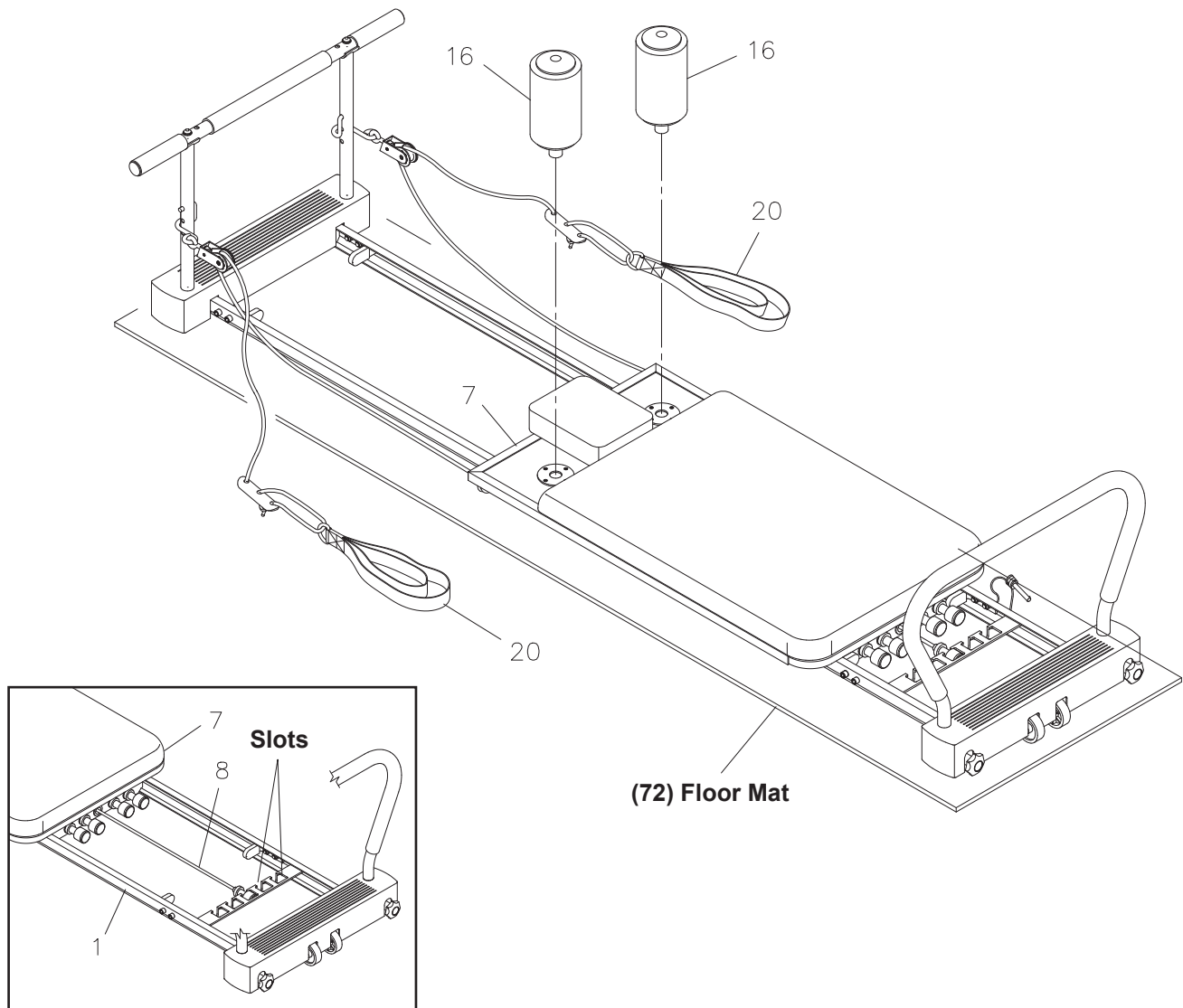

## OPERATIONAL INSTRUCTIONS

### LOAD ADJUSTMENT

There are three different tension levels for the tension cords.

- **LOW TENSION CORD, YELLOW(8)**
- **MEDIUM TENSION CORD, BLACK(9)**
- **HIGH TENSION CORD, RED(10)**

The resistance of the **PLATFORM(7)** can be adjusted by securing the **TENSION CORDS(8, 9, 10)** in the slots on the **FRONT FRAME(1)**. You can achieve various levels of resistance by securing different numbers of the **TENSION CORDS(8, 9, 10)** in the slots.

**NOTE:** Over time your **TENSION CORDS(8, 9, 10)** will relax. To increase resistance in the **TENSION CORDS(8, 9, 10)**, stretch and re-tie the tension cords in a more taut position.

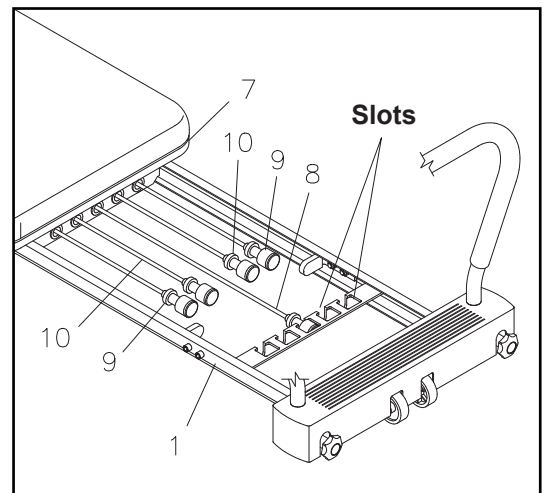

### HEADREST ADJUSTMENT

The **HEADREST(14)** on the **PLATFORM(7)** can be positioned at an incline by simply pivoting the **SUPPORT BRACKET** underneath the **HEADREST(14)**.

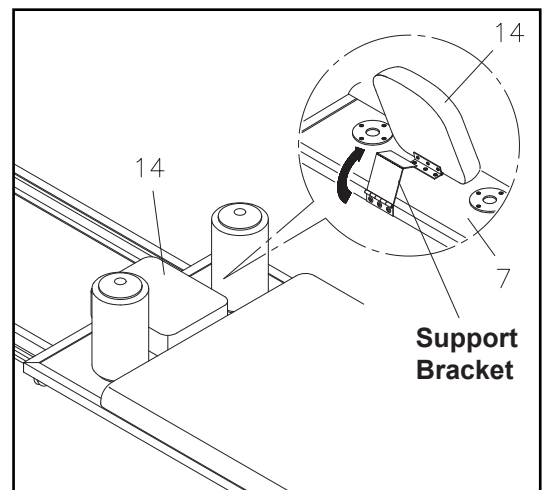

### HAND/FOOT STRAP ADJUSTMENT

The position of the **HAND/FOOT STRAP(20)** can be adjusted by pulling the **ROPE(19)** through the **ROPE ADJUSTMENT BRACKET(21)** as shown. Be sure to adjust both **HAND/FOOT STRAPS(20)** to the same position on both sides.

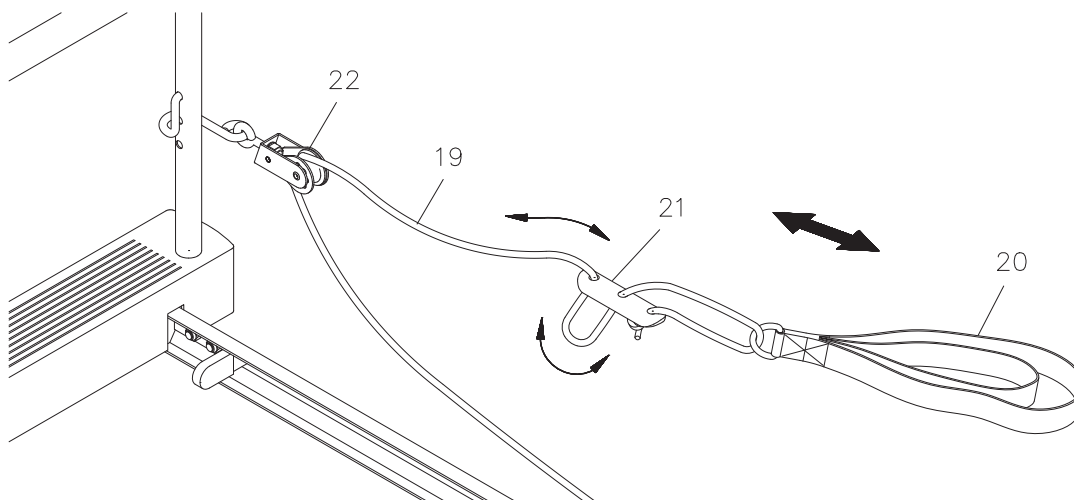

## OPERATIONAL INSTRUCTIONS

### PILLOW ADJUSTMENT AND USE

The **HEAD & NECK SUPPORT PILLOW(71)** is designed to support the natural curve of your neck. It can be used to provide comfort, support and postural alignment for reformer exercises that are performed while lying on your back. Do not use the **HEAD & NECK SUPPORT PILLOW(71)** for exercises that require you to lift your hips higher than your head.

With the **HEADREST(14)** in the flat position, place the **HEAD & NECK SUPPORT PILLOW(71)** on top of the **HEADREST(14)** with the thickest part of the **HEAD & NECK SUPPORT PILLOW(71)** under your neck. Make sure that the elastic strap on the **HEAD & NECK SUPPORT PILLOW(71)** is around the **HEADREST(14)**.

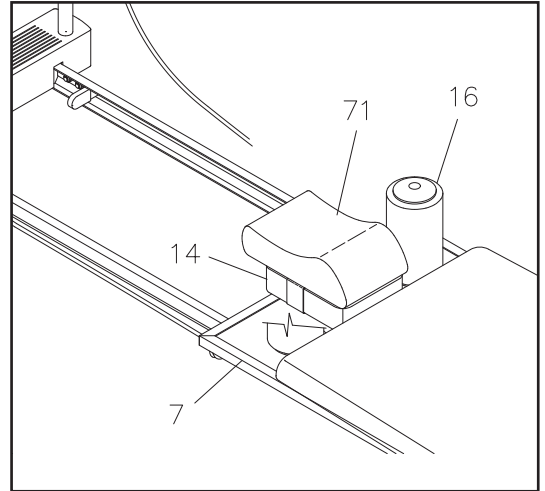

**Make sure that both FOAM PADS(16) are in the PLATFORM(7) when using the HEAD & NECK SUPPORT PILLOW(71) attached to the HEADREST(14).**

## OPERATIONAL INSTRUCTIONS

### CUSTOMIZING ROPE LENGTH

Ideal rope length will vary depending on your height and limb length. To determine your ideal rope length, begin by placing the hand/foot straps over the shoulder rests as shown below. Adjust the ropes so they are taut. For complete rope length adjustment instructions, see additional Rope Length Adjustment instructions in this Owner's Manual.



Next, lie on the reformer with your hands in the straps with shoulders against the shoulder rests. Reach your hands toward the ceiling until they are directly over the back edge of the reformer platform as shown below. In this position, the reformer platform should be at rest with no tension on the ropes. If there is still tension on the ropes in this position, lengthen the ropes. If you lose tension before reaching the arm position shown below, shorten the ropes.

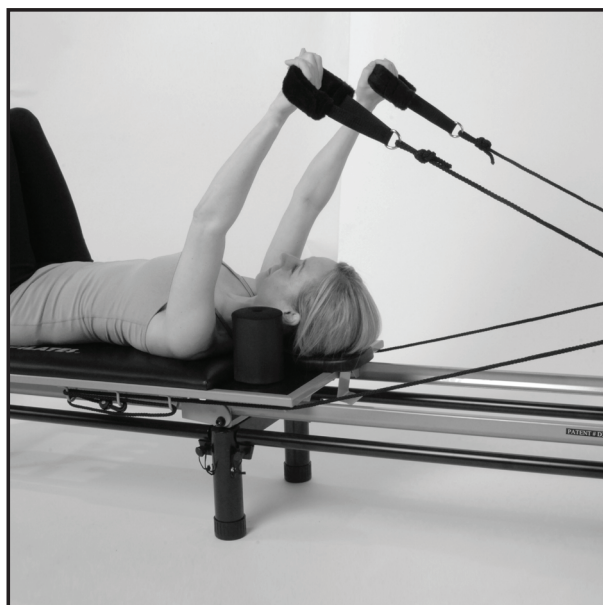

## OPERATIONAL INSTRUCTIONS

### PULLEY HEIGHT ADJUSTMENT

#### Standard Setting- the top hole

The standard height setting for the reformer pulleys is the top setting. At the top setting, the pull of the ropes provides the most support and feedback for the body. Place your pulleys at the top setting to most easily achieve proper form and to engage the core muscles.



#### Variable settings- lower holes

You can add variety to your routine by using different pulley settings. The lower you set the pulleys, the less guidance and support you receive from the ropes. By providing less guidance and support, the lower settings further challenge strength and coordination.



## OPERATIONAL INSTRUCTIONS

### RESISTANCE CORD STRENGTH

The approximate maximum resistance provided by each cord is outlined in the chart below. Frequency of use, type of use and user weight will have an effect on the strength of your cords. Over time cord strength will gradually decrease. If your reformer is under the 90 day warranty, replacement cords are available by contacting Stamina customer care at [customer.care@staminaproducts.com](mailto:customer.care@staminaproducts.com). If your reformer is not under warranty or you would like to add different tension cords, you can purchase new cords by visiting our website [www.aeropilates.com](http://www.aeropilates.com).

TENSION CORDS	CORD RESISTANCE
YELLOW	approximately 16 pounds
BLACK	approximately 24 pounds
RED	approximately 34 pounds

### TENSION CORD SELECTION

The **AeroPilates®** workout wall chart and workout DVDs indicate which cords to use for each exercise.

### TENSION CORD REPLACEMENT

To replace or add a tension cord, first carefully release the platform and tip your machine on its side. Untie the knot that secures the cord you are replacing and simply pull it out. Thread the new cord through the metal holes from the end of the platform to the other end.

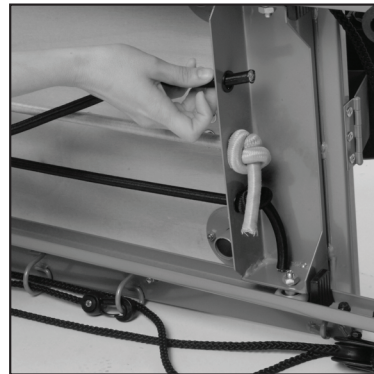

Pull tightly on the cord stretching it to the point that allows you to tie a double knot, and release the cord into place.

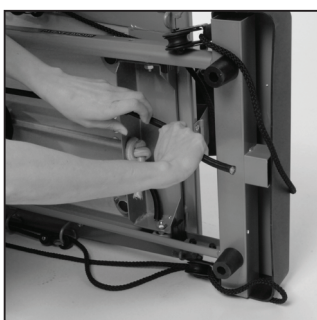

1

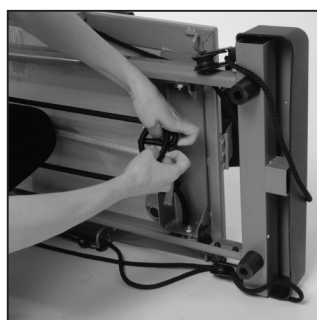

2

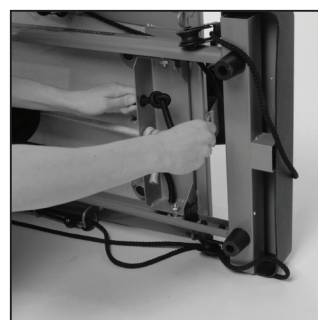

3



4



## OPERATIONAL INSTRUCTIONS

### PLATFORM ROLLER REPLACEMENT

To replace a platform roller, first remove the platform by releasing the cords and sliding the platform all the way back to the top end or rear frame of the machine. Tip your machine on its side, bend the machine at the hinge, and simply slide the platform off the frame.



Turn the platform upside down so it is cord side up. Using a crescent wrench and flat head screwdriver, remove the screw that is holding the roller in place. Replace the old roller with the new one, add the washer, push the screw through the roller and tighten with the nut. Do not overtighten the nut and make sure the roller turns easily.

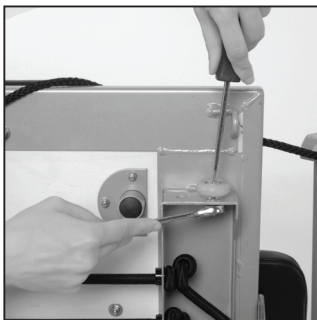

1



2



3

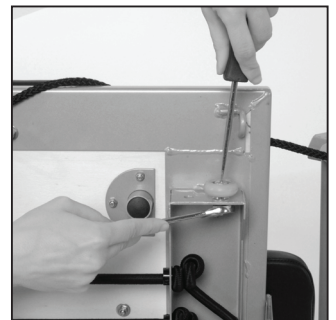

4

### WEBSITE RESOURCES

You can find use and maintenance instructional video clips at [www.staminaproducts.com](http://www.staminaproducts.com) and [www.aeropilates.com](http://www.aeropilates.com).

## STORAGE

- To store the Pilates Home Studio, simply keep it in a clean dry place.
- The **FRONT FRAME(1)** of the Pilates Home Studio has built-in **WHEELS(27)** for easy moving. To move, be sure at least one of the tension cords is attached to prevent the **PLATFORM(7)** from sliding, then lift from the end of the **REAR FRAME(2)** and roll.
- The Pilates Home Studio folds for storage. To fold, be sure no tension cords are attached and slide the **PLATFORM(7)** to the end of the **REAR FRAME(2)**. Remove the **FOOTBAR(5)**, **CARDIO REBOUNDER(50)**, **FOAM PAD ASSEMBLIES(16)**, and **PULLEY RISERS(25)**, then lift the Pilates Home Studio onto its side with the **LOCKING PIN(28)** side up. With the machine hinging in the middle, move the **FRONT FRAME(1)** toward the **REAR FRAME(2)** until the frame ends meet. Insert the **LOCKING PIN(28)** into the hole in the **REAR FRAME(2)**, and the Pilates Home Studio is ready to store.

**⚠ CAUTION** Keep hands clear of the hinge when folding and unfolding the unit.

## MAINTENANCE

The safety and integrity designed into the Pilates Home Studio can only be maintained when the Pilates Home Studio is regularly examined for damage and wear. Special attention should be given to the following:

- It is the sole responsibility of the user/owner to ensure that regular maintenance is performed.
- Worn or damaged components must be replaced immediately or the Pilates Home Studio should be removed from service until repair is made.
- Verify that the **CAUTION LABEL(62)** and **PINCH POINT CAUTION LABEL(18)** are in place and easy to read. Call Stamina Products immediately at 1-800-375-7520 for a replacement caution label if one is missing or damaged.
- Verify that the **ROPES(19)** are properly installed on the **PULLEY SETS(22)**.
- Check the condition of the **ROPES(19)** and replace if they are frayed or worn.
- Check the **TENSION CORDS(8, 9, 10)**. If any of the **TENSION CORDS(8, 9, 10)** are stretched and loose, re-tie the knot on the end of the cord. Replace **TENSION CORDS(8, 9, 10)** that are frayed or worn.
- Check the **BUNGEE CORD(52)** on the **CARDIO REBOUNDER(50)** for wear. Replace the **BUNGEE CORD(52)** if it is frayed or worn.
- Check the **PULLEY SETS(22)** for excessive wear. Replace worn **PULLEY SETS(22)**.
- Check the **HAND/FOOT STRAPS(20)** for damage. Replace damaged parts.
- Check the **FOAM SLEEVE(6)** and **FOAM PADS(16)** and replace if damaged or worn.
- Check the **STOP PLATES(29)** for looseness or damage and replace any damaged parts.
- Check the **PLATFORM CUSHION(13)** and replace if it is damaged or worn.
- Check and clean the **ROLLERS(32)** and the rolling surfaces on the rails. Clean by wiping with a dry cloth.
- Only Stamina Products supplied components should be used to maintain/repair the Pilates Home Studio.
- Keep your Pilates Home Studio clean by wiping it off with an absorbent cloth after use.

## CONDITIONING GUIDELINES

How you begin your exercise program depends on your physical condition. If you have been inactive for several years or are severely overweight, start slowly and increase your workout time gradually. Increase your workout intensity gradually by monitoring your heart rate while you exercise.

Remember to follow these essentials:

- Have your doctor review your training and diet programs.
- Begin your training program slowly with realistic goals that have been set by you and your physician.
- Warm up before you exercise and cool down after you work out.
- Take your pulse periodically during your workout and strive to stay within a range of 60% (lower intensity) to 90% (higher intensity) of your maximum heart rate zone. Start at the lower intensity, and build up to higher intensity as you become more aerobically fit.
- If you feel dizzy or lightheaded you should slow down or stop exercising.

Initially you may only be able to exercise within your target zone for a few minutes; however, your aerobic capacity will improve over the next six to eight weeks. It is important to pace yourself while you exercise so you don't tire too quickly.

To determine if you are working out at the correct intensity, use a heart rate monitor or use the table below. For effective aerobic exercise, your heart rate should be maintained at a level between 60% and 90% of your maximum heart rate. If just starting an exercise program, work out at the low end of your target heart rate zone. As your aerobic capacity improves, gradually increase the intensity of your workout by increasing your heart rate.

Measure your heart rate periodically during your workout by stopping the exercise but continuing to move your legs or walk around. Place two or three fingers on your wrist and take a six second heartbeat count. Multiply the results by ten to find your heart rate. For example, if your six second heartbeat count is 14, your heart rate is 140 beats per minute. A six second count is used because your heart rate will drop rapidly when you stop exercising. Adjust the intensity of your exercise until your heart rate is at the proper level.

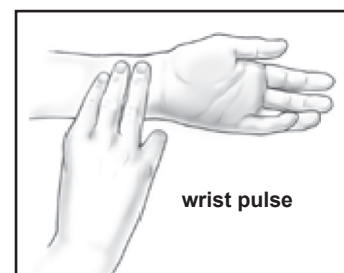

Target Heart Rate Zone Estimated by Age\*

Age	Target Heart Rate Zone (55%-90% of Maximum Heart Rate)	Average Maximum Heart Rate 100%
20 years	110-180 beats per minute	200 beats per minute
25 years	107-175 beats per minute	195 beats per minute
30 years	105-171 beats per minute	190 beats per minute
35 years	102-166 beats per minute	185 beats per minute
40 years	99-162 beats per minute	180 beats per minute
45 years	97-157 beats per minute	175 beats per minute
50 years	94-153 beats per minute	170 beats per minute
55 years	91-148 beats per minute	165 beats per minute
60 years	88-144 beats per minute	160 beats per minute
65 years	85-139 beats per minute	155 beats per minute
70 years	83-135 beats per minute	150 beats per minute

\* For cardiorespiratory training benefits, the American College of Sports Medicine recommends working out within a heart rate range of 55% to 90% of maximum heart rate. To predict the maximum heart rate, the following formula was used:  $220 - \text{Age} = \text{predicted maximum heart rate}$

## ***WARM-UP and COOL-DOWN***

**Warm-Up** The purpose of warming up is to prepare your body for exercise and to minimize injuries. Warm up for two to five minutes before strength training or aerobic exercising. Perform activities that raise your heart rate and warm the working muscles. Activities may include brisk walking, jogging, jumping jacks, jump rope, and running in place.

**Cool-Down** The purpose of cooling down is to return the body to its normal, or near normal, resting state at the end of each exercise session. A proper cool-down slowly lowers your heart rate and allows blood to return to the heart. Your cool down should be completed after each strength training session.

## LIMITED WARRANTY

MODEL 55-5107

### WARRANTY

Stamina Products, Inc. ("Stamina") warrants to the original purchaser that this product will be free from defects in materials and workmanship that arise under normal use, service, proper assembly and proper operation in accordance with product warnings/instructions for a period of 90 days on the parts and three years on the frame from the date of the original purchase from an authorized retailer. **THIS WARRANTY SHALL NOT APPLY TO ANY PRODUCT WHICH HAS BEEN SUBJECT TO COMMERCIAL USE, ABUSE, MISUSE, ALTERATION OF ANY KIND OR TO ANY DEFECT OR CHANGE CAUSED BY IMPROPER ASSEMBLY, REPAIR, REPLACEMENT, SUBSTITUTION OR USE WITH PARTS NOT PROVIDED BY STAMINA.** Commercial use includes use of product in athletic clubs, health clubs, spas, gyms, and all other public or semipublic facilities whether or not the product's use is in furtherance of a profit making enterprise, and all other use which is not for personal purposes.

To implement this limited warranty, send a written notice stating your name, date, and place of purchase and a brief description of the defect along with your receipt to Stamina Products, Inc. 2040 N Alliance Ave, Springfield, Missouri, USA, MO 65803, or email us at [customer.care@staminaproducts.com](mailto:customer.care@staminaproducts.com), or call us at 1-800-375-7520. If the defect is covered under this limited warranty, you will be requested to return the product or part to us for free repair or replacement at our option.

**NO ACTION FOR BREACH OF THIS LIMITED WARRANTY MAY BE COMMENCED MORE THAN ONE (1) YEAR AFTER THE DATE THE ALLEGED BREACH WAS OR SHOULD HAVE BEEN DISCOVERED. NO ACTION FOR BREACH OF ANY IMPLIED WARRANTY (INCLUDING MERCHANTABILITY AND FITNESS FOR A PARTICULAR PURPOSE) MAY BE COMMENCED MORE THAN ONE (1) YEAR AFTER DELIVERY OF THE PRODUCT TO THE PURCHASER.** These warranties are not transferable. **IF ANY PART OF THE PRODUCT IS NOT IN COMPLIANCE WITH THIS LIMITED WARRANTY OR ANY IMPLIED WARRANTY, THE REMEDY OF REPAIR OR REPLACEMENT IS THE EXCLUSIVE REMEDY.** If any claim is made under this limited warranty or any implied warranty, Stamina reserves the right to require the product to be returned for inspection, at the purchaser's expense, to Stamina's premises in Springfield, Missouri. Return of the enclosed warranty registration card is not required for warranty coverage, but is merely a way of establishing the date and place of purchase.

Stamina **SHALL NOT BE LIABLE FOR THE LOSS OF USE OF ANY PRODUCT, LOSS OF TIME, INCONVENIENCE, COMMERCIAL LOSS OR ANY OTHER INDIRECT, CONSEQUENTIAL, SPECIAL OR INCIDENTAL DAMAGES DUE TO BREACH OF THE ABOVE WARRANTY OR ANY IMPLIED WARRANTY.**

**THIS LIMITED WARRANTY IS THE ONLY EXPRESS WARRANTY. NO ORAL OR WRITTEN INFORMATION GIVEN BY STAMINA, ITS AGENTS OR EMPLOYEES, SHALL CREATE A WARRANTY OR IN ANY WAY INCREASE THE SCOPE OF THIS WARRANTY.** This warranty gives you specific legal rights, and you may also have other legal rights which vary from state to state. **ANY OTHER RIGHT WHICH YOU MAY HAVE, INCLUDING ANY IMPLIED WARRANTY OF MERCHANTABILITY OR FITNESS FOR A PARTICULAR PURPOSE, IS LIMITED IN DURATION TO THE DURATION OF THIS WARRANTY.**

The laws in some states affect the disclaimer or limitation of implied warranties and consequential and incidental damages. If any such law is found applicable, the foregoing disclaimers and limitations of and on implied warranties and consequential and incidental damages shall be deemed to be modified to the extent necessary to comply with applicable law.

# PRODUCT PARTS DRAWING

**BACK**

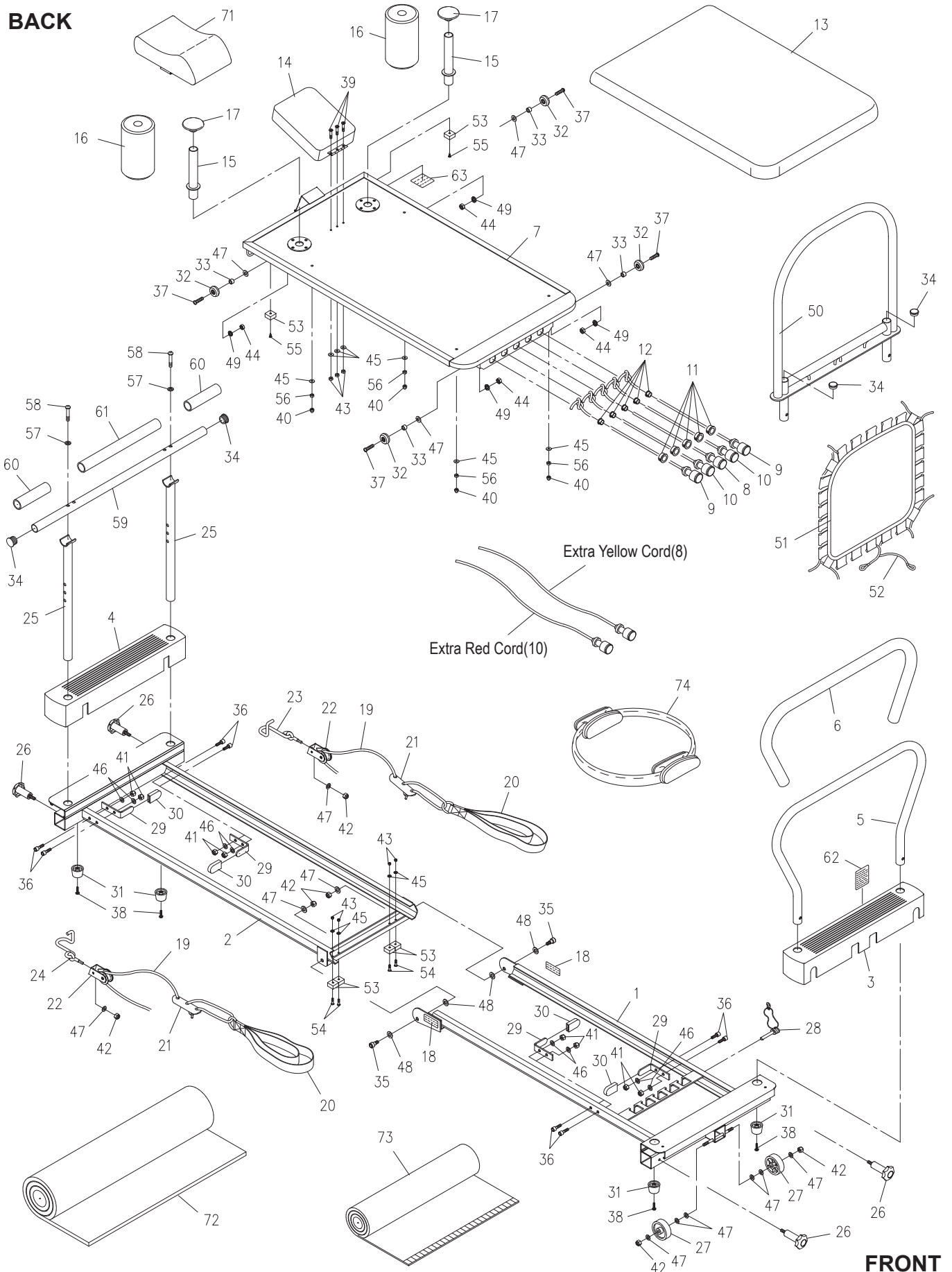

**FRONT**

## PARTS LIST

PART#	PART NAME	QTY
1	Front Frame	1
2	Rear Frame	1
3	Front Cover	1
4	Rear Cover	1
5	Footbar	1
6	Foam Sleeve	1
7	Platform	1
8	Low Tension Cord, Yellow Color	2
9	Medium Tension Cord, Black Color	2
10	High Tension Cord, Red Color	3
11	Support Bushing	5
12	Stop Bushing	5
13	Platform Cushion	1
14	Headrest	1
15	Foam Pad Tube	2
16	Foam Pad	2
17	Foam Cap	2
18	Pinch Point Caution Label	2
19	Rope	2
20	Hand/Foot Strap	2
21	Rope Adjustment Bracket	2
22	Pulley Set	2
23	Left Pulley Hook	1
24	Right Pulley Hook	1
25	Pulley Riser	2
26	Locking Knob	4
27	Wheel	2
28	Locking Pin	1
29	Stop Plate	4
30	Stop Pad	4
31	Rubber Foot	4
32	Roller	4
33	Roller Spacer	4
34	Round Plug (25mm)	4
35	Shaft Bolt, Socket Head (M8 x 1.25 x 20mm)	2
36	Bolt, Socket Head (M6 x 1 x 14mm)	8
37	Bolt, Round Head (M8 x 1.25 x 30mm)	4
38	Screw, Round Head (M5 x 0.8 x 35mm)	4
39	Screw, Flat Head (M5 x 0.8 x 25mm)	3
40	Acorn Nut (M5 x 0.8)	4
41	Nylock Nut (M6 x 1)	8
42	Nylock Nut (M8 x 1.25)	6
43	Nylock Nut (M5 x 0.8)	7
44	Nut (M8 x 1.25)	4
45	Washer (M5)	11
46	Washer (M6)	8
47	Washer (M8)	14

## **PARTS LIST**

<b>PART#</b>	<b>PART NAME</b>	<b>QTY</b>
48	Washer (M10)	4
49	Lock Washer (M8)	4
50	Cardio Rebounder	1
51	Mat	1
52	Bungee Cord	1
53	Rubber Stand	6
54	Screw, Flat Head (M5 x 0.8 x 16mm)	4
55	Screw, Round Head (M5 x 12mm)	2
56	Nut (M5 x 0.8)	4
57	Arc Washer (M8)	2
58	Bolt, Button Head (M8 x 1.25 x 42mm)	2
59	Pull-Up Bar	1
60	Foam Grip	2
61	Long Foam Grip	1
62	Caution Label	1
63	Serial Decal	1
71	Head & Neck Support Pillow	1
72	Floor Mat	1
73	Towel	1
74	Magic Circle	1
75	Allen Wrench (5mm)	1
76	Combination Wrench	1
77	Socket Wrench	1
78	AeroPilates® Primer (DVD)	1
79	AeroPilates® Basic Workout Package (DVD)	1
80	AeroPilates® Stretching (DVD)	1
81	AeroPilates® Strength and Stamina (DVD)	1
82	AeroPilates® Fat Burning Cardio (DVD)	1
83	AeroPilates® Total Body Tone and Lengthen (DVD)	1
84	Workout Chart	1
85	Manual	1



## TO CONTACT CUSTOMER CARE

For your convenience, Stamina's customer care representatives can be reached by email at [customer.care@staminaproducts.com](mailto:customer.care@staminaproducts.com) or by phone at 1-800-375-7520 (in the U.S.). Our customer care representatives are available Monday through Thursday from 7:30 a.m. until 5:00 p.m., and Friday 8:00 a.m. until 3 p.m. Central Time.



**ONLINE  
CUSTOMER CARE**  
customer.care@staminaproducts.com  
www.staminaproducts.com



**TELEPHONE  
CUSTOMER CARE**  
Tel: 1 (800) 375-7520



**FAX  
CUSTOMER CARE**  
Fax: (417) 889-8064



**MAIL**  
**STAMINA PRODUCTS, INC.**  
ATTN: Customer Care  
2040 N Alliance Ave, Springfield, MO 65803

Would you like to receive email information or special offers from Stamina Products? Register at [contact.staminaproducts.com](http://contact.staminaproducts.com)

## TO REGISTER YOUR PRODUCT

To enact your warranty, please register your product by going to [register.staminaproducts.com](http://register.staminaproducts.com). Please have your product model number (printed on the cover of this owner's manual) and the serial number (printed on the black and white sticker on your product) ready.

If you don't have internet access, you can call customer care at 1-800-375-7520, or fill out and mail the product registration form below to Stamina Products, Inc.; 2040 N Alliance Ave, Springfield, MO 65803.

<b>PRODUCT REGISTRATION FORM</b>		<b>Stamina Products, Inc.</b> 2040 N Alliance Ave, Springfield, MO 65803	
Model Number: .....		Serial Number: .....	
Product Name: .....			
Place Purchased: .....			
Date of Purchase: .....		Purchase Price: .....	
First Name: .....		Last Name: .....	
City: .....	State: .....	Phone #: (     ) .....	Zip Code: .....
Email Address: .....		Phone #: (     ) .....	
Would you like to receive email information or special offers from Stamina Products?* <input type="checkbox"/> Yes <input type="checkbox"/> No *If yes, be sure your email address is included above.			



Detach and Mail or Fax the Form Above



## TO ORDER PARTS

If there are missing or damaged parts, you can go to [parts.staminaproducts.com](http://parts.staminaproducts.com) and order those parts. If you have questions, please contact customer care. Do not return the product. To order parts by mail, fill out the sheet below and fax it to 417-889-8064. The part will be mailed to your address.



Detach and Mail or Fax the Form Below



<b>PARTS ORDER FORM</b>		<b>Stamina Products, Inc.</b> 2040 N Alliance Ave, Springfield, MO 65803	
Mr./Ms: .....			
Address: .....		Apt. #: .....	
City: .....	State: .....	Zip Code: .....	
<b>IMPORTANT : We require your phone number to process the order!</b>			
Phone #: (     ) .....		Work Phone #: (     ) .....	
Date of Purchase: .....			
Model #: .....			
Purchased From: .....			
<b>IMPORTANT: Before filling out the portion below, make sure you have the correct information. Refer to the parts list to make sure you're ordering the right parts!</b>			
PART #	DESCRIPTION	QUANTITY	
EXAMPLE: 1	Rear Unit Assembly	1	