

AVARI

PROGRAMMABLE MAGNETIC ROWER

Owner's Manual

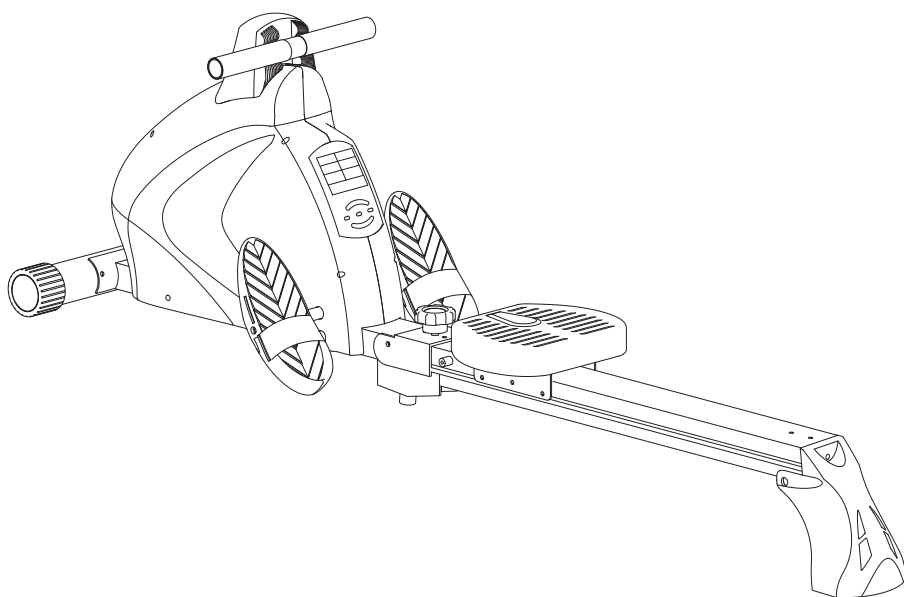

Product May Vary Slightly From Pictured.

CAUTION:

Weight on this product should not exceed 275 lbs.

⚠ WARNING

Exercise can present a health risk. Consult a physician before beginning any exercise program with this equipment. If you feel faint or dizzy, immediately discontinue use of this equipment. Serious bodily injury can occur if this equipment is not assembled and used correctly. Serious bodily injury can also occur if all instructions are not followed. Keep others and pets away from equipment when in use. Always make sure all bolts and nuts are securely tightened prior to each use. Follow all safety instructions in this manual.

When calling for parts or service, please specify the following numbers:

Model#: A350-700C

S/N: _____

This Product is Distributed Exclusively by



2040 N Alliance Ave, Springfield, MO 65803

Customer Care

1 (800) 375-7520

www.staminaproducts.com

STAMINA PRODUCTS
MADE IN TAIWAN

© 2021 Stamina Products, Inc.
2021, 05

müüv

Quickstart Guide

IMPORTANT

Smart Audio Workouts for Your Rower



Go to the App Store on your device or scan the QR Code for quick access.



Download the app and get moving!

Assembly video included in app.

TABLE OF CONTENTS

Safety Instructions	3	Maintenance	21
Before You Begin	5	Conditioning Guidelines	22
Equipment Warning, Caution & Notice Labels ...	6	Warm-Up and Cool-Down	23
Hardware Identification Chart	7	Product Parts Drawing	24
Assembly Instructions	8	Parts List	25
Operational Instructions	12	Warranty	27
Computer Instructions	14	Notes	28
Storage	21	Fax/Mail Ordering Form	30

SAFETY INSTRUCTIONS

⚠ WARNING Cancer and Reproductive Harm www.P65Warnings.ca.gov

⚠ WARNING Consult your physician before starting this or any exercise program. This is especially important if you are over the age of 35, have never exercised before, are pregnant, or suffer from any health problem. This product is for home use only. Do not use in institutional or commercial applications. Failure to follow all warnings and instructions could result in serious injury or death.

⚠ WARNING To reduce the risk of serious injury, read the following Safety Instructions before using the AVARI® Programmable Magnetic Rower.

1. Save these instructions and ensure that other exercisers read this manual prior to using the AVARI® Programmable Magnetic Rower for the first time.
2. Read all warnings and cautions posted on the AVARI® Programmable Magnetic Rower.
3. The AVARI® Programmable Magnetic Rower should only be used after a thorough review of the Owner's Manual. Make sure that it is properly assembled and tightened before use.
4. We recommend that two people be available for assembly of this product.
5. Keep children away from the AVARI® Programmable Magnetic Rower. Do not allow children to use or play on the AVARI® Programmable Magnetic Rower. Keep children and pets away from the AVARI® Programmable Magnetic Rower when it is in use.
6. It is recommended that you place this exercise equipment on an equipment mat.
7. Set up and operate the AVARI® Programmable Magnetic Rower on a solid level surface. Do not position the AVARI® Programmable Magnetic Rower on loose rugs or uneven surfaces.
8. Make sure that adequate space is available for access to and around the AVARI® Programmable Magnetic Rower.
9. Before using, inspect the AVARI® Programmable Magnetic Rower for worn or loose components, and securely tighten or replace any worn or loose components prior to use.
10. Before using, check the condition of the STRAP(27). Replace the STRAP(27) if it is cracked or broken.
11. Consult a physician prior to commencing an exercise program and follow his/her recommendations in developing your fitness program. If at any time during exercise you feel faint, dizzy, or experience pain, stop and consult your physician.
12. Always choose the workout which best fits your physical strength and flexibility level. Know your limits and train within them. Always use common sense when exercising.
13. Do not wear loose or dangling clothing while using the AVARI® Programmable Magnetic Rower.
14. Never exercise in bare feet or socks; always wear proper footwear such as running, walking, or cross training shoes that fit well, provide foot support, and feature non-skid rubber soles.
15. Be careful to maintain your balance while using, mounting, dismounting, or assembling the AVARI® Programmable Magnetic Rower, loss of balance may result in a fall and bodily injury.
16. Do not use the SEAT(20) to move the AVARI® Programmable Magnetic Rower. The SEAT(20) will move and the SEAT CARRIAGE(6) may pinch your hand or fingers. When folding or unfolding the unit, keep all children away and make sure your hands are clear of any folding or pinch point.
17. The AVARI® Programmable Magnetic Rower should not be used by persons weighing over 275 pounds.
18. The AVARI® Programmable Magnetic Rower should be used by only one person at a time.
19. The AVARI® Programmable Magnetic Rower is for consumer use only. It is not for use in public or semipublic facilities.

EXTEND YOUR PARTS WARRANTY TO 180 DAYS FROM THE DATE OF PURCHASE. REGISTER YOUR PRODUCT.



**NEED HELP?
CONTACT US FIRST
1 (800) 375-7520
customer.care@staminaproducts.com**

Hi! From all of us here at Stamina Products, thank you for your purchase. We know that you have big fitness goals in mind and we are here to help you along. Call us, email us, or send us a message on Facebook. Be sure to contact us if you have any questions on your new product. We look forward to hearing from you!

With your body in mind,
Stamina Customer Care

To enact your extended warranty and to help us better serve you, please go online and register your new product.

register.staminaproducts.com

It is quick and easy to register online, but if you're a little old school or just need a reason to raise that little flag on your mailbox, fill out the info on the last page of this manual and mail it in.



ONLINE

customer.care@staminaproducts.com
www.staminaproducts.com



TELEPHONE

1 (800) 375-7520



FAX

(417) 889-8064



MAIL

Stamina Products, Inc.
ATTN: Customer Care
2040 N Alliance Ave
Springfield, MO 65803

 facebook.com/StaminaProducts
facebook.com/AeroPilates

CUSTOMER CARE HOURS:
Monday-Thursday, 7:30 AM-5:00 PM, Central Time
Friday, 8:00 AM-3:00 PM, Central Time

BEFORE YOU BEGIN

Thank you for choosing the **AVARI® Programmable Magnetic Rower**. We take great pride in this quality product and hope it will provide many hours of quality exercise to make you feel better, look better, and enjoy life to its fullest.

It's a proven fact that a regular exercise program can improve your physical and mental health. Too often, our busy lifestyles limit our time and opportunity to exercise. The **AVARI® Programmable Magnetic Rower** provides a convenient and simple method to begin your journey of getting your body in shape and achieving a happier and healthier lifestyle.

Before reading further, please review the drawing below and familiarize yourself with the parts that are labeled. Locate the serial decal on the product and write the serial number on the cover of the manual in the space provided. See the next page for an image of the serial decal. Model number and serial number are required when

calling for assistance.

Read this manual carefully before using the **AVARI® Programmable Magnetic Rower**.

Providing you with a quality product is Stamina's top priority. However, sometimes there could be a missing or incorrectly sized part. If you have any questions or problems with the parts included with your **AVARI® Programmable Magnetic Rower**, please do not return the product. Contact us **FIRST!**

If a part is missing or defective, please contact Customer Care for assistance. Call us toll free at 1-800-375-7520 (in the U.S.) or live chat on staminaproducts.com. Our Customer Care Staff is available to assist you from 7:30 A.M. to 5:00 P.M. (Central Time) Monday through Thursday and 8:00 A.M. to 3:00 P.M. (Central Time) on Friday.

Be sure to have the name and model number of the product available when you contact us.

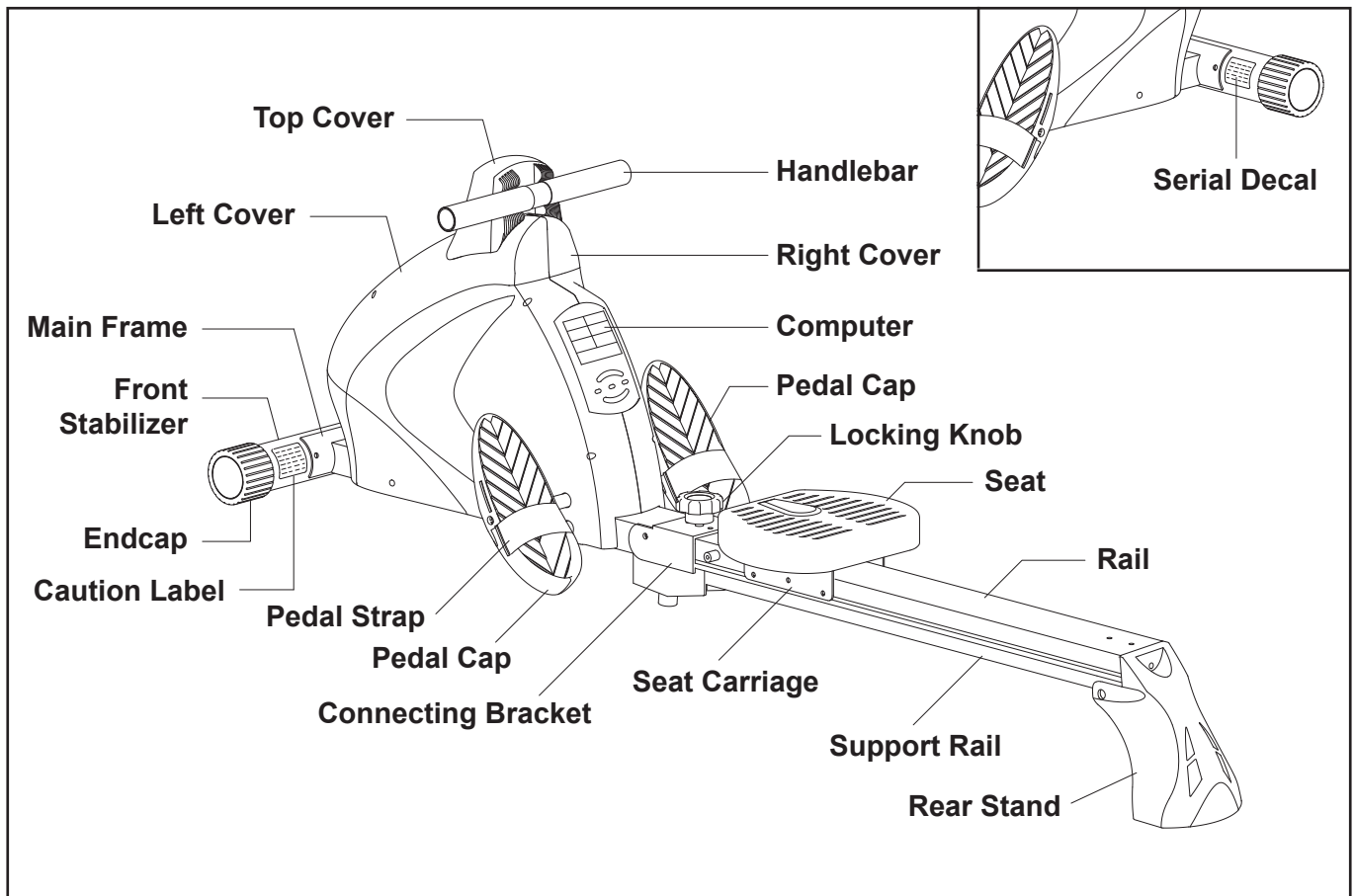

THE FOLLOWING TOOLS ARE INCLUDED FOR ASSEMBLY :

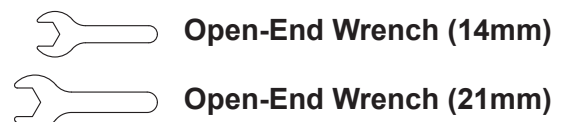

EQUIPMENT WARNING, CAUTION & NOTICE LABELS

This chart is provided to help identify the warning, caution, and notice labels on the **AVARI® Programmable Magnetic Rower**. Please take a moment to familiarize yourself with all of the warning, caution, and notice labels.

CAUTION LABEL(86)



PINCH POINT CAUTION LABEL(87)



SERIAL DECAL(93)



To best serve you, our Customer Care Representatives will need your serial number. For quick access, write in your serial number on the cover of the manual.

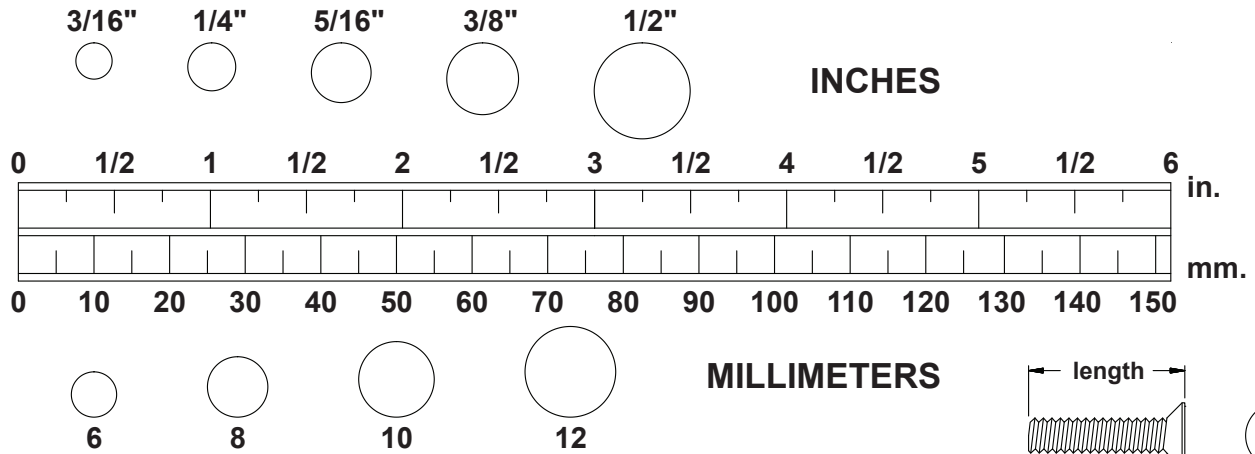

HARDWARE IDENTIFICATION CHART

This chart is provided to help identify the hardware used in the assembly process. Place the washers or the ends of the bolts or screws on the circles to check for the correct diameter. Use the small scale to check the length of the bolts and screws.

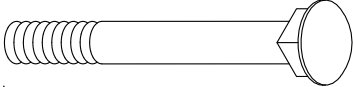
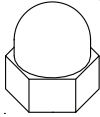
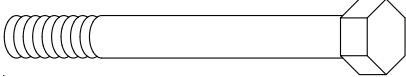
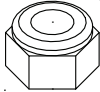
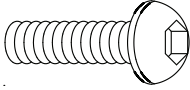

NOTICE: The length of all bolts and screws, except those with flat heads, is measured from below the head to the end of the bolt or screw. Flat head bolts and screws are measured from the top of the head to the end of the bolt or screw.

After unpacking the unit, open the hardware bag and make sure that you have all the following items. Some hardware may be already attached to the part.

	Part Number and Description	Qty
	39 Carriage Bolt (M8 x 1.25 x 90mm)	2
	40 Acorn Nut (M8 x 1.25)	2
	48 Shaft Bolt	4
	49 Bolt, Hex Head (3/8"-16 x 4.7")	1
	50 Nylock Nut (3/8"-16)	1
	62 Bolt, Button Head (M8 x 1.25 x 35mm)	1
	65 Washer (M8)	2
	78 Large Washer (ø13 x ø25 x 2mm thick)	1

ASSEMBLY INSTRUCTIONS

Place all parts from the box in a cleared area and position them on the floor in front of you. Remove all packing materials from your area and place them back into the box. Do not dispose of the packing materials until assembly is completed. Read each step carefully before beginning. If you are missing a part, please go to staminaproducts.com under the Customer Care section and order the part needed, e-mail us at customer.care@staminaproducts.com, or call us toll free at 1-800-375-7520 (in the U.S.). Our Customer Care Staff is available to assist you from 7:30 A.M. to 5:00 P.M. (Central Time) Monday through Thursday and 8:00 A.M. to 3:00 P.M. (Central Time) on Friday.

Some product parts are fit tested at the factory to ensure proper fit and alignment. Marks in the paint may be noticeable, but are not an indication of damage.

STEP 1

Remove your **AVARI® Programmable Magnetic Rower** from its packaging, placing the **HANDLEBAR (32)** on the **HANDLEBAR HOLDER (16)**.

STEP 2

Position the **FRONT STABILIZER (2)** as the illustration below shown so the **CAUTION LABEL (86)** is on the left side. Attach the **FRONT STABILIZER (2)** to the **MAIN FRAME (1)** with **CARRIAGE BOLTS (M8x1.25x90mm) (39)**, **WASHERS (M8) (65)**, and **ACORN NUTS (M8x1.25) (40)**.

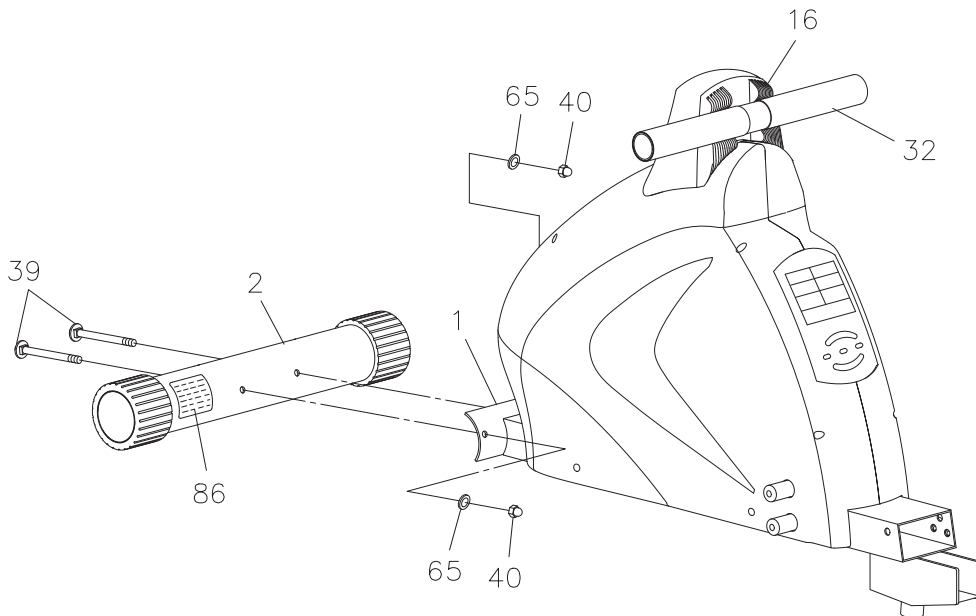

ASSEMBLY INSTRUCTIONS

STEP 3

Install the **RAIL(4)** by attaching the **CONNECTING BRACKET(5)** to the **MAIN FRAME(1)** with **HEX BOLT (3/8"-16 x 4.7")(49)** and **NYLOCK NUT(3/8"-16)(50)**. Do not over-tighten. The **RAIL(4)** should be able to rotate on the **HEX BOLT(3/8"-16 x 4.7")(49)**.

STEP 4

Lock the **RAIL(4)** in place by screwing the **SPRING PIN(23)** into the **CONNECTING BRACKET(5)**. The pin of the **SPRING PIN(23)** must go through the hole in the **MAIN FRAME(1)** to properly lock the **RAIL(4)**.

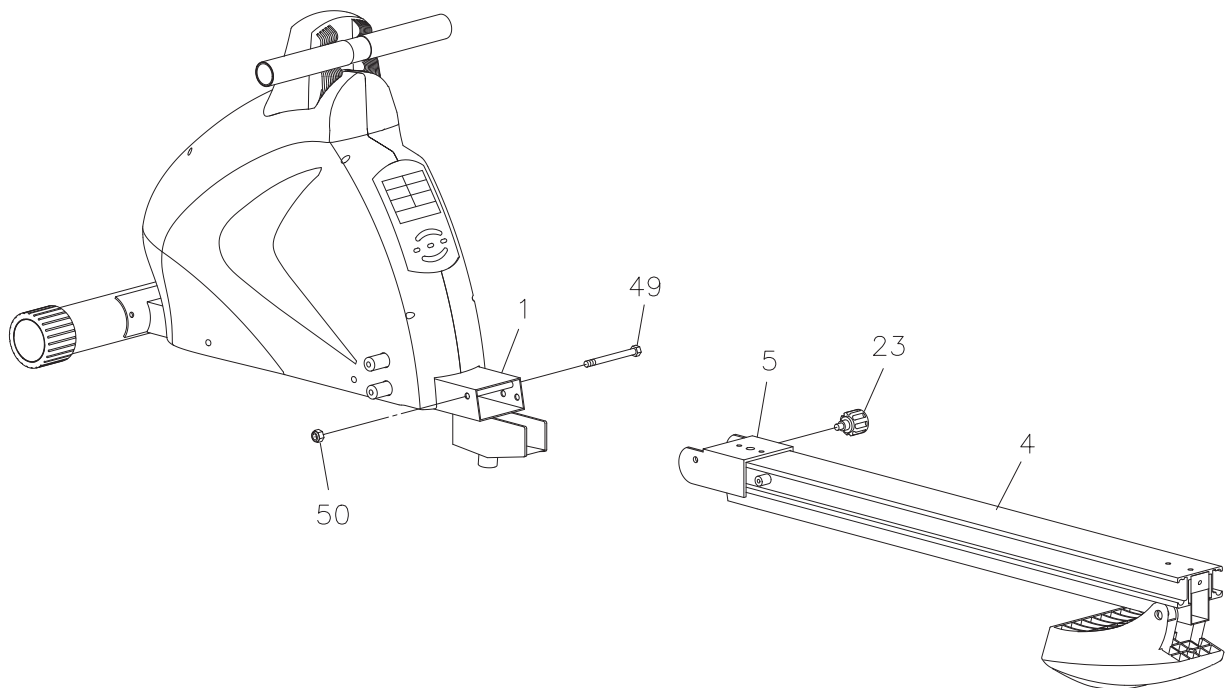

ASSEMBLY INSTRUCTIONS

STEP 5

Secure the **RAIL(4)** to the **MAIN FRAME(1)** by inserting the **LOCKING KNOB(22)** through the **LARGE WASHER(78)** and the **CONNECTING BRACKET(5)**, and screwing it securely into the **MAIN FRAME(1)**.

STEP 6

Refer to the illustration below. Slide the **SEAT ASSEMBLY(20)** onto the **RAIL(4)**. Unfold the **REAR STAND(18)** and secure with **BUTTON HEAD BOLT(M8X1.25x35mm)(62)**.

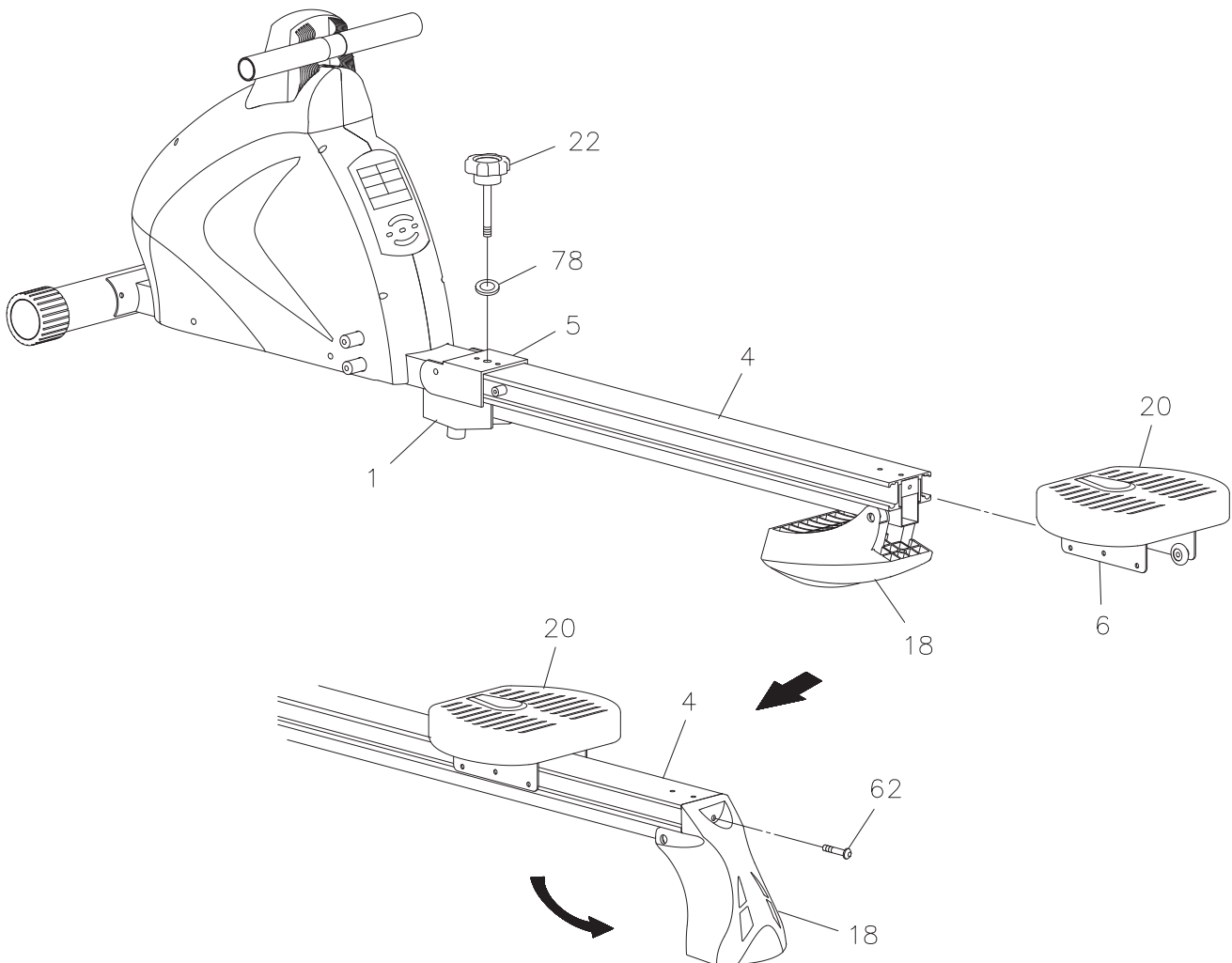

ASSEMBLY INSTRUCTIONS

STEP 7

Thread and tighten the **SHAFT BOLTS(48)** into the lower threaded receptacles on the **MAIN FRAME(1)** on both sides to serve as the stopper for the **PEDAL CAPS(13)**.

STEP 8

Attach the **PEDAL CAPS(13)** to the **MAIN FRAME(1)** with the **SHAFT BOLTS(48)** on both sides.

STEP 9

Refer to illustration A. Plug the **ADAPTER(101)** into the **SOCKET** of the **POWER WIRE(99)** located on the front of the rower. Plug the **ADAPTER(101)** into an electrical outlet.

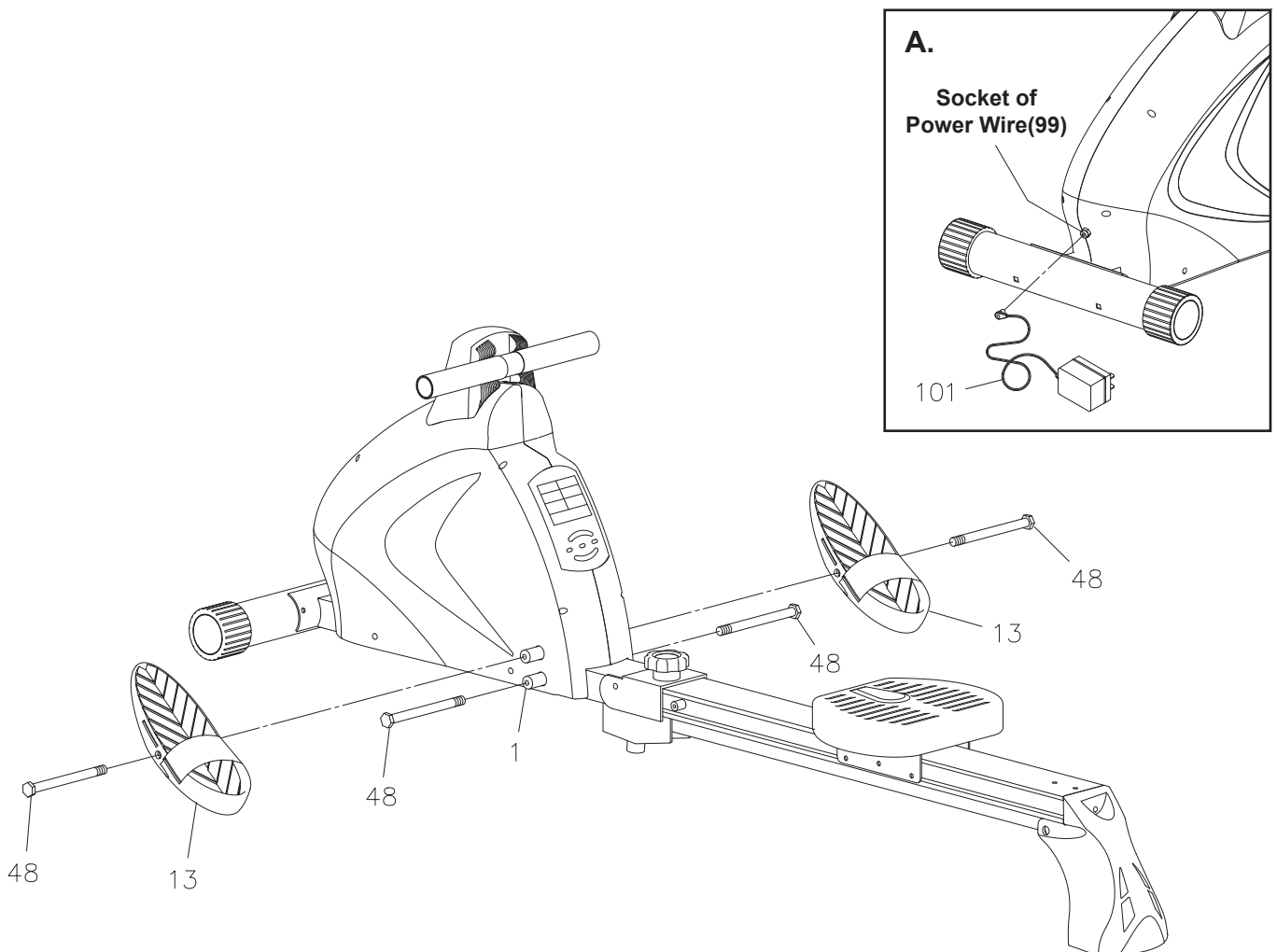

OPERATIONAL INSTRUCTIONS

HEART RATE TRANSMITTER

The **AVARI® Programmable Magnetic Rower** can measure how hard you are exercising by monitoring your heart rate with the **HEART RATE TRANSMITTER(81)**. Your heart rate reading gives you a snapshot of how hard your heart is working at that point in your workout by measuring the number of heart beats per minute.

The **HEART RATE TRANSMITTER(81)** worn around your chest sends your heart rate information to a receiver inside the **COMPUTER(15)** so your heart rate is tracked while you exercise. This is the most reliable way to measure your heart rate to make sure you are exercising within your target heart rate zone so you get the most out of your workout time.

Using the Heart Rate Transmitter Chest Strap

The **HEART RATE TRANSMITTER(81)** worn around the chest is powered by a **BUTTON BATTERY (CR2032)(85)** located in the center of the strap. Two electrodes on either side of the battery monitor your heartbeat, and an adjustable **ELASTIC STRAP(82)** holds the transmitter in place. The receiver built into the **AVARI® Programmable Magnetic Rower** picks up your heart rate from the **HEART RATE TRANSMITTER(81)** and displays it on the monitor during your workout.

To assemble the **HEART RATE TRANSMITTER(81)**, insert the **BUTTON BATTERY(CR2032)(85)** as shown in the illustration. Place the **BATTERY RUBBER RING(83)** on the edge of the opening and place the **BATTERY COVER(84)** over the **BUTTON BATTERY(CR2032)(85)**. Using a coin or similar object, press down on the **BATTERY COVER(84)** and turn to securely close the cover.

- NOTE:** 1. Make sure to close the **BATTERY COVER(84)** very tightly as illustrated to prevent sweat and moisture from damaging the battery.
2. The **HEART RATE TRANSMITTER(81)** is latex free and its material is appropriate for human contact.

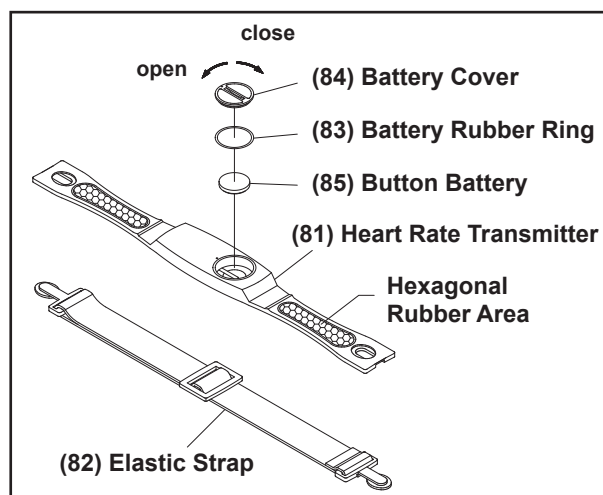

Attach the **ELASTIC STRAP(82)** by inserting the oval-shaped tabs through the openings in the transmitter and twisting. Adjust the **ELASTIC STRAP(82)** to fit your chest snugly as shown in the illustration below.

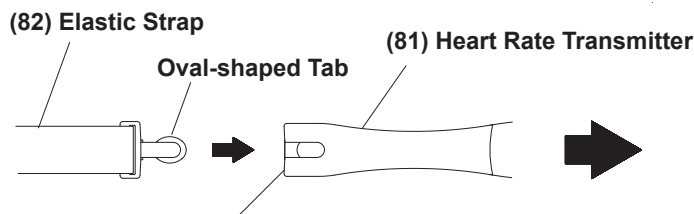

To ensure a secure connection above, be sure that the front edge of the oval-shaped tab is completely inside of the oval-shaped opening on the **HEART RATE TRANSMITTER(81)**.

NOTE: Apply water or conductive gel to moisten the rubber area where with hexagons covering the electrodes. This rubber area must be wet and in contact with your chest skin to properly detect your heart rate.

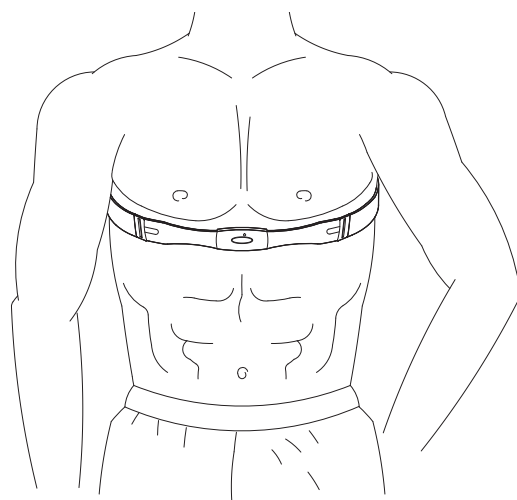

OPERATIONAL INSTRUCTIONS

Transmission LED Indicator

For checking operation of transmitter, the red LED indicator will flash indicating the transmitter is in operation. Adjust the transmitter position to keep the LED indicator flashing consistently for accurate readings. (See illustration below.)

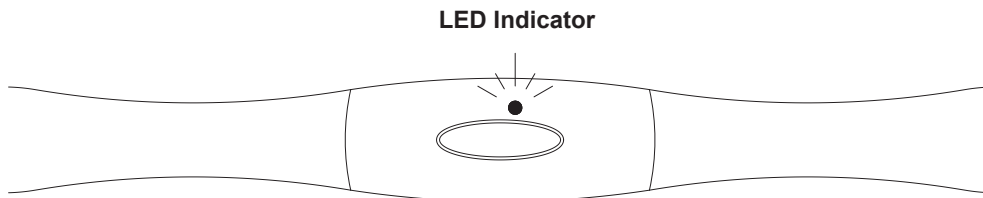

NOTE: If your heart rate is inconsistent or not tracking on your workout console, do the following:

- Moisten the hexagonal rubber areas covering the electrodes on the back of the chest strap and make sure they are in contact with the skin. Your skin may be dry when you begin your workout and the moisture is necessary to ensure contact. As you sweat, contact will improve.
- Tighten the elastic strap so it remains in place as you exercise. Movement of the electrodes will result in inaccurate or erratic signal and readings.
- Clean the electrodes as dirt can interfere with transmission. Use a mild soap and water and dry with a soft towel.

Transmitter Care and Maintenance

- Wash regularly with mild soap and water solution and dry with a soft towel being careful not to abrade the electrodes.
- Store in a cool, dry place. Make sure the electrodes aren't stored with any wet material and never store a wet transmitter in non-breathable material like a plastic bag or sports bag.
- Do not bend or stretch the transmitter.

NOTE: The frequency of the receiver built into the **AVARI® Programmable Magnetic Rower** is 5 kHz. All compatible heart rate transmitters from other companies are allowed for use with the **AVARI® Programmable Magnetic Rower**.

COMPUTER INSTRUCTIONS

Your **AVARI® Programmable Magnetic Rower** utilizes a magnetic braking system to create resistance for your workout. You control the amount and pattern of this resistance by means of the advanced computer console built into the **AVARI® Programmable Magnetic Rower**. We recommend that you use this computer console to vary your workout from session to session and note your progress toward your fitness goals. When used regularly in this way, the computer console can become an important source of motivation and interest which will help keep you on track.

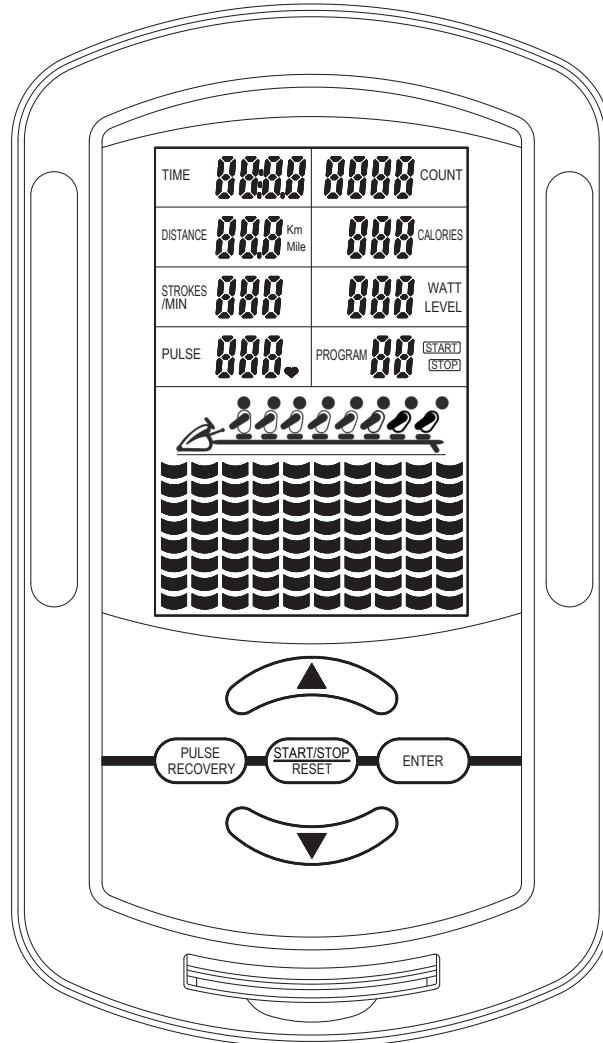

FUNCTION BUTTONS:

ENTER: Press to confirm the selected Program 1 to Program 12 and the preset values.

START/STOP/RESET: Press to start the selected program. Press the **START/STOP/RESET** button to stop the program. You can press the **START/STOP/RESET** button again to continue to run the current program, or use “▲/▼” buttons to select a new program.

Press and hold the button down for two seconds to reset all of the function values to zero.

▲ (UP): Press to select Program 1 to Program 12. Press to increase the preset values. Press to increase the level of the workload when running a program.

▼ (DOWN): Press to select Program 1 to Program 12. Press to decrease the preset values. Press to decrease the level of the workload when running a program.

PULSE RECOVERY: Press to activate the pulse recovery function after training. You must wear the **HEART RATE TRANSMITTER(81)** around your chest to measure your heart rate.

COMPUTER INSTRUCTIONS

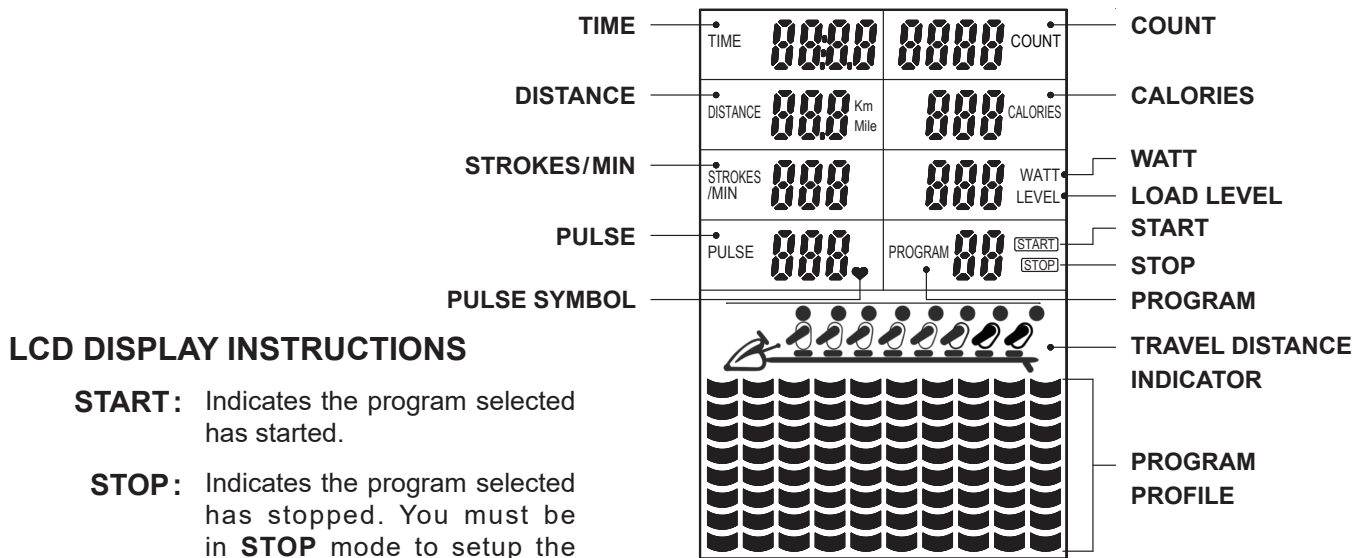

LCD DISPLAY INSTRUCTIONS

START: Indicates the program selected has started.

STOP: Indicates the program selected has stopped. You must be in **STOP** mode to setup the programs.

PROGRAM: Displays a flashing “1” during setup to select from Program 1 to Program 12. Displays the selected program during exercise.

TIME: Displays a flashing “0:00” during setup to preset the program from 1:00 to 99:00 for Program 1 (manual program) or from 5:00 to 99:00 for Program 2 to Program 12, and counts down from the preset value. If no value is preset, displays the time during exercise, from 1 second up to 99:59 minutes.

COUNT: Displays a flashing “0” during setup to preset the number of rows you want to complete, from zero to 9990, and counts down from the preset value. If no value is preset, displays the total number of rows you have completed during exercise, from zero up to 9999 rows.

DISTANCE: Displays a flashing “0” during setup to preset the distance, from 100 meter to 99.9 Km, and counts down from the preset value. The display will show “meters” from 1 meter to 999 meters, then it will change to “Km” and change after each 0.1 Km (100 meters). If no value is preset, displays the distance you have travelled during exercise, from zero up to 99.9 km.

CALORIES: Displays a flashing “0.0” during setup to preset calorie consumption, from zero to 999 Kcal, and counts down from the preset value.

Displays the calories consumed, from zero up to 999 Kcal.

NOTE: The calorie readouts are an estimate for an average user. It should be used only as a comparison between workouts on this unit.

STROKES/MIN: Displays the current strokes per minute during exercise, from zero to 999 strokes per minute.

WATT: Displays the amount of power being exerted, from zero to 999 watt.

LEVEL: Displays the level of the workload when running a program. Use the “▲/▼” buttons to adjust the workload, from 1 to 16 level.

Displays the workload level when presetting each of the 10 intervals for Program 9 to Program 12.

PULSE: Displays the heart rate, from 40 to 240 beats per minute. To use this function, you must wear the **HEART RATE TRANSMITTER(81)** around your chest so the receiver that is built into the rower registers your heart rate from the **HEART RATE TRANSMITTER(81)** to display it. Each heart rate signal will be accompanied with one “♥” symbol flash. If you do not wear the **HEART RATE TRANSMITTER(81)** around your chest correctly, a “P” mark will be displayed.

NOTE: The **HEART RATE TRANSMITTER(81)** is not a medical device. Maintaining a consistent signal can be difficult due to the varying distances experienced during the rowing stroke. The pulse function is a great tool to optimize your workout, but should be used as a reference only.



TRAVEL DISTANCE INDICATOR:

Indicates the travel distance on the rower during exercise.

COMPUTER INSTRUCTIONS

PROGRAM DESCRIPTIONS

This computer contains 12 different programs. You can preset the program time and the computer will divide the time into 10 intervals. If you do not set the program time in advance, the computer will use the preset value of 30 minutes for Program 1 to Program 12 and cycle run the program profile.

(PROGRAM 1) MANUAL

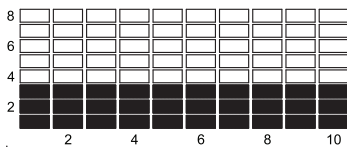

MANUAL PROGRAM: Program 1 is a manual program allowing the user to have full manual control of the workload. Use the “▲” button to increase the load. Use the “▼” button to decrease the load.

PRESET PROGRAMS: Program 2 to Program 7 are preset automatic programs. The profiles are shown on the face of the computer. Use the “▲” button to increase the load level of the program. Use the “▼” button to decrease the load level of the program.

(PROGRAM 2) ROLLING

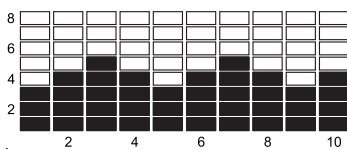

(PROGRAM 3) VALLEY

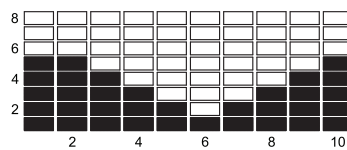

(PROGRAM 4) FAT BURN

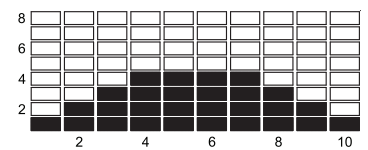

(PROGRAM 5) RAMP

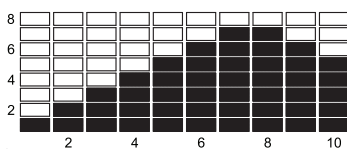

(PROGRAM 6) MOUNTAIN

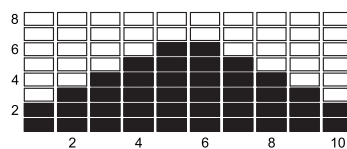

(PROGRAM 7) INTERVALS

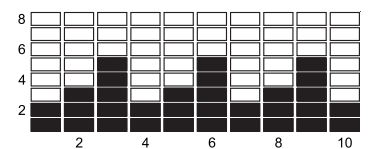

(PROGRAM 8) Target Heart Rate

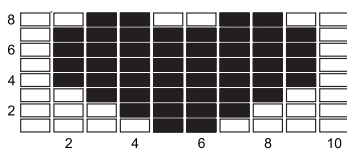

TARGET HEART RATE CONTROL PROGRAM: To use this program, you must wear the **HEART RATE TRANSMITTER(81)** around your chest so the receiver which is built into the rower registers your heart rate from the **HEART RATE TRANSMITTER(81)** for working with this program.

Once Program 8 is selected, the **PULSE** window displays flashing “90” for you to input desired target heart rate, from 90 to 220. The program will monitor your heart rate and adjust the workload automatically during exercise to keep your heart rate within the zone which is plus & minus 5 Heart Beats from the target heart rate you setup.

COMPUTER INSTRUCTIONS

HEART RATE MONITORING

To get the maximum benefit from your **AVARI® Programmable Magnetic Rower** workout it is important that you exercise within your target heart rate zone for at least 20 minutes. Research has shown that working out below your target heart rate zone won't burn fat or improve your cardiovascular fitness, and working above your target heart rate zone is also counter productive.

Everyone has their own target heart rate zone and exercising within that zone should be your goal every time you work out. Finding your personal target heart rate zone is calculated by:

STEP 1: Find your maximum heart rate with this simple formula:

$220 - \text{Age} = \text{predicted maximum heart rate}$

Example: A 40-year-old would have a predicted maximum heart rate of 180 beats per minute, $220 - 40 = 180$.

STEP 2: Your target heart rate zone is a range that is 55% to 90% of your maximum heart rate.*

Predicted Maximum Heart Rate x .55 = lower end of target heart rate zone

Predicted Maximum Heart Rate x .90 = upper end of target heart rate zone

Example: A 40-year-old would have a Target Heart Rate Zone of 99 to 162 beats per minute; $180 \times .55 = 99$. $180 \times .90 = 162$.

For more conditioning guidelines to set up the target heart rate for the program, the chart at the right shows the Target Heart Rate Zones estimated by Age.

* For cardiorespiratory training benefits, the American College of Sports Medicine recommends working out within a heart rate range of 55% to 90% of maximum heart rate.

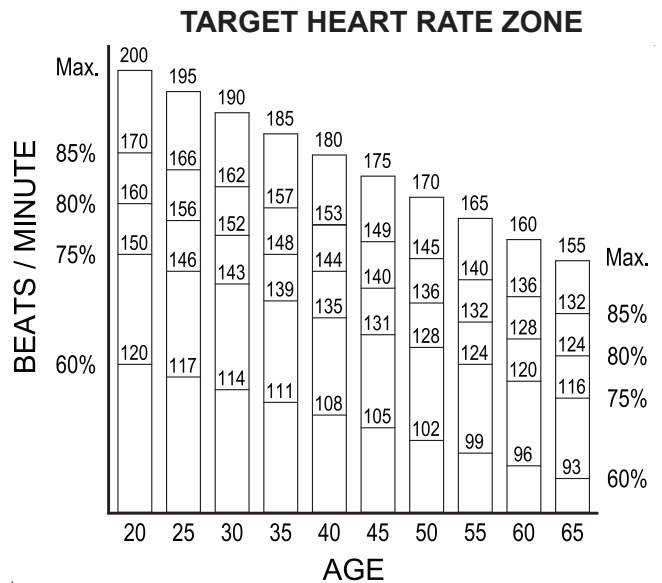

USER SETTING PROGRAMS: Program 9 to Program 12 are the automatic programs that allow the user to manually preset each of the 10 intervals. Under **STOP** mode, use “▲/▼” and “**ENTER**” buttons to edit the program profile. The program profile will be stored in the memory after setup. You can modify the profile anytime under the **STOP** mode. **NOTE: The changes can be stored only under STOP mode.**

When running a program, you still can use the “▲” button to increase the load level of the program. Use the “▼” button to decrease the load level of the program. These changes will not be stored in memory.

(PROGRAM 9 to 12)

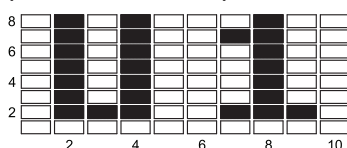

PROGRAM 9: U1
PROGRAM 10: U2
PROGRAM 11: U3
PROGRAM 12: U4

NOTE: Display U1 to U4 for Program 9 to 12.

COMPUTER INSTRUCTIONS

OPERATION INSTRUCTIONS

A. MANUAL AND PRESET PROGRAMS (PROGRAM 1 to PROGRAM 7)

STEP 1: POWER ON

Handlebar Pulling or press any button.

STEP 2 : SELECT PROGRAM

The Program 1 (Manual Program) is always displayed first when you turn on the computer. Press the **ENTER** button to select the Program 1 (Manual Program). Or press the “▲/▼” buttons to select other programs.

STEP 3: SET THE PROGRAM TIME or DISTANCE, COUNT, and CALORIES

Press the **ENTER** button to select the desired program. The computer will go through the input items as follows and allow you to set the function values. Use “▲/▼” and **ENTER** buttons to input the values. Or press the **ENTER** button to pass some of the inputs.

Time (5:00* to 99:00) → Count (0 to 9990 rows) → Distance (100 meter to 99.9 km) → Calories (0 to 999 Kcal)

**For program 1 (Manual Program), the preset program time is from 1:00 to 99:00 minutes.*

STEP 4 : START TO WORKOUT

Now you are ready to begin exercising. The program will not start until you press the **START/STOP/RESET** button.

B. HEART RATE CONTROL PROGRAMS (PROGRAM 8)

NOTE: To use this program, you must wear the **HEART RATE TRANSMITTER(81)** around your chest.

STEP 1: POWER ON

Handlebar Pulling or press any button.

STEP 2 : SELECT PROGRAM

Press “▲/▼” buttons until Program 8 is displayed.

STEP 3: SET THE PROGRAM TIME or DISTANCE, COUNT, CALORIES, and PULSE

Press the **ENTER** button to select the program. The computer will go through the input items as follows and allow you to set the function values. Use “▲/▼” and **ENTER** buttons to input the values. Or press the **ENTER** button to pass some of the inputs.

Time (5:00 to 99:00) → Count (0 to 9990 rows) → Distance (100 meter to 99.9 km) → Calories (0 to 999 Kcal)
→ Pulse (90 to 220 beats per minute)

STEP 4 : START TO WORKOUT

Press the **START/STOP/RESET** button to start to workout.

COMPUTER INSTRUCTIONS

C. USER SETTING PROGRAMS (PROGRAM 9 to 12)

STEP 1: POWER ON

Handlebar Pulling or press any button.

STEP 2 : SELECT PROGRAM

Press “▲/▼” buttons until the desired program is displayed.

STEP 3: SET THE PROGRAM TIME or DISTANCE, COUNT, and CALORIES

Press the **ENTER** button to select the desired program. The computer will go through the input items as follows and allow you to set the function values. Use “▲/▼” and **ENTER** buttons to input the values. Or press the **ENTER** button to pass some of the inputs.

Time (5:00 to 99:00) → Count (0 to 9990 rows) → Distance (100 meter to 99.9 km) → Calories (0 to 999 Kcal)

STEP 4 : EDIT THE PROGRAM PROFILE

Press the **ENTER** button, interval 1 will begin flashing. Use “▲/▼” buttons to set the load level, from 1 to 16, for interval 1. Press the **ENTER** button to proceed to the next interval. Use “▲/▼” buttons to set the load for each interval.

STEP 5 : START TO WORKOUT

Press the **START/STOP/RESET** button to start to workout.

OPERATION DESCRIPTIONS

1. You may preset values for several functions. The preset function values will start to count down once you press the **START/STOP/RESET** button to start exercising. Preset values will only count down, they will not count up. When you complete one of the preset functions, the computer will remind you with an audible alarm for five seconds and stops running the program. Press any button to stop the audible alarm. Two possible options follow: Option A: press the **START/STOP/RESET** button to continue to run the current program. The value of this completed function will start to count up, while the other preset functions will continue to count down until you reach the next preset function. Option B: press **ENTER** button and use “▲/▼” buttons to select a new program.
2. To stop a running program, press the **START/STOP/RESET** button. In this mode, you can press the **START/STOP/RESET** button again to continue to run the current program. Or, you can use “▲/▼” buttons to select a new program.
3. If you want to restart with a new program, press and hold the **START/STOP/RESET** button down for two seconds to reset all of the function values to zero. Use “▲/▼” buttons to select a new program.
4. The computer will shut off automatically after 4 minutes of inactivity and all function values will be reset to zero.

5. You can change the unit of distance from Kilometers to Miles. Press **ENTER** and **PULSE RECOVERY** buttons at the same time and hold the buttons down for six seconds. The computer will turn off the display for four seconds, and then restart the display into the programming mode during these six seconds. Refer to the illustration for the programming mode.

Press **ENTER** button, nine times, to pass the settings until the “Km” is flashing. Use the “▲/▼” buttons to select “Mile”, then press **ENTER** button, three times, to confirm the change and skip out of the programming mode.

Select one of the desired units, Km or Mile.

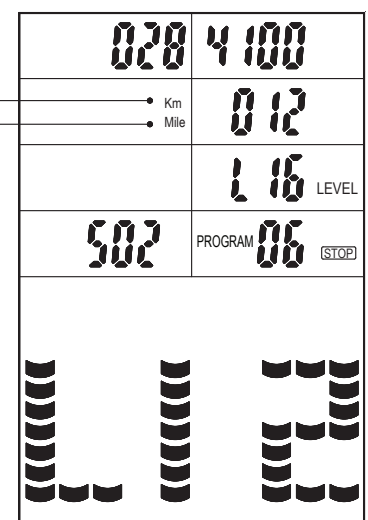

COMPUTER INSTRUCTIONS

D. PULSE RECOVERY FUNCTION

NOTE: To use this program, you must wear the **HEART RATE TRANSMITTER(81)** around your chest.

The **PULSE RECOVERY** function measures how quickly you return to a resting heart rate after exercising. You can use this function to measure improvement as you get into shape. The computer will monitor your heart rate for 60 seconds and calculate a Pulse Recovery value from F1 to F6.

F1.0 = Excellent
F4.0 = Below Average

F2.0 = Good
F5.0 = Not Good

F3.0 = Fair
F6.0 = Poor

The readout should only be used as a comparison between workouts. It can be used right after any aerobic exercise. Stop exercising before starting this function.

To start the pulse recovery function, your heart rate will be displayed approximately five (5) seconds after the heart symbol is displayed. Then press the **PULSE RECOVERY** button. During the pulse recovery function, only **PULSE** and **TIME** are working and the display will be as shown in illustration A. **TIME** will count down from 0:60 and the heart symbol will be blinking. When the **TIME** reaches 0, the computer will show your pulse recovery condition from **F1.0** to **F6.0**. See illustration B. Press any button to exit the pulse recovery function to skip to **STOP** mode.

- NOTE:**
1. You can press the **PULSE RECOVERY** button in any time to run pulse recovery program, even during your exercising and running other program.
 2. Once the pulse recovery function starts, the **TIME** will count down from 60 seconds to zero. You can press and hold the **START/STOP/RESET** button down for two seconds to quit the pulse recovery function. If no heart rate signal is available, a "P" mark will display in **PULSE** window.

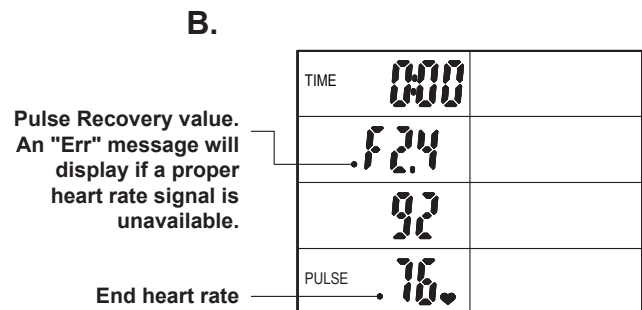
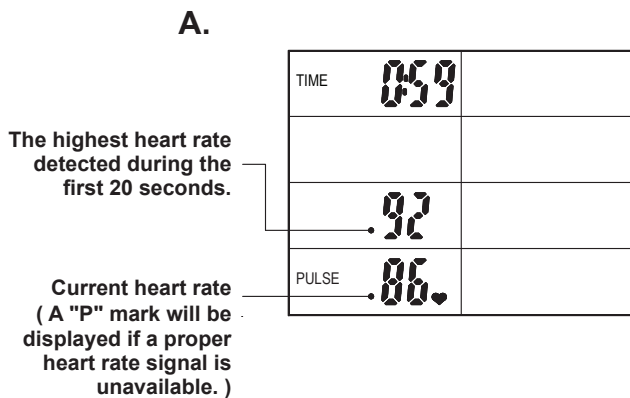

POWER SOURCE:

The computer uses the **ADAPTER(101)** as a power source. Use the **AVARI® Programmable Magnetic Rower** with the **ADAPTER(101)** plugged into an electrical outlet.

STORAGE

1. To store the **AVARI® Programmable Magnetic Rower**, simply keep it in a clean dry place.
2. Move the **AVARI® Programmable Magnetic Rower** with the moving wheels on the **FRONT STABILIZER(2)**. Lift the **REAR STAND(18)** to move the **AVARI® Programmable Magnetic Rower**. Do not use the **SEAT(20)** to move the **AVARI® Programmable Magnetic Rower**. The **SEAT(20)** will move and the **SEAT CARRIAGE(6)** may pinch your hand or fingers.
3. Follow the following process to fold The **AVARI® Programmable Magnetic Rower** as illustrated for easy storage.
 - a. Remove the **LOCKING KNOB(22)** and **LARGE WASHER(78)** from the **CONNECTING BRACKET(5)**.
 - b. Pull out the **SPRING KNOB(23)** and fold up the **RAIL(4)**. Make sure the **RAIL(4)** is locked securely in the folded position by the **SPRING KNOB(23)**.
 - c. Store the **LOCKING KNOB(22)** and **LARGE WASHER(78)** by inserting the **LOCKING KNOB(22)** through the **LARGE WASHER(78)** and slide it into the **SUPPORT RAIL(3)**.

⚠ CAUTION Keep hands clear of the hinge when folding and unfolding the unit.

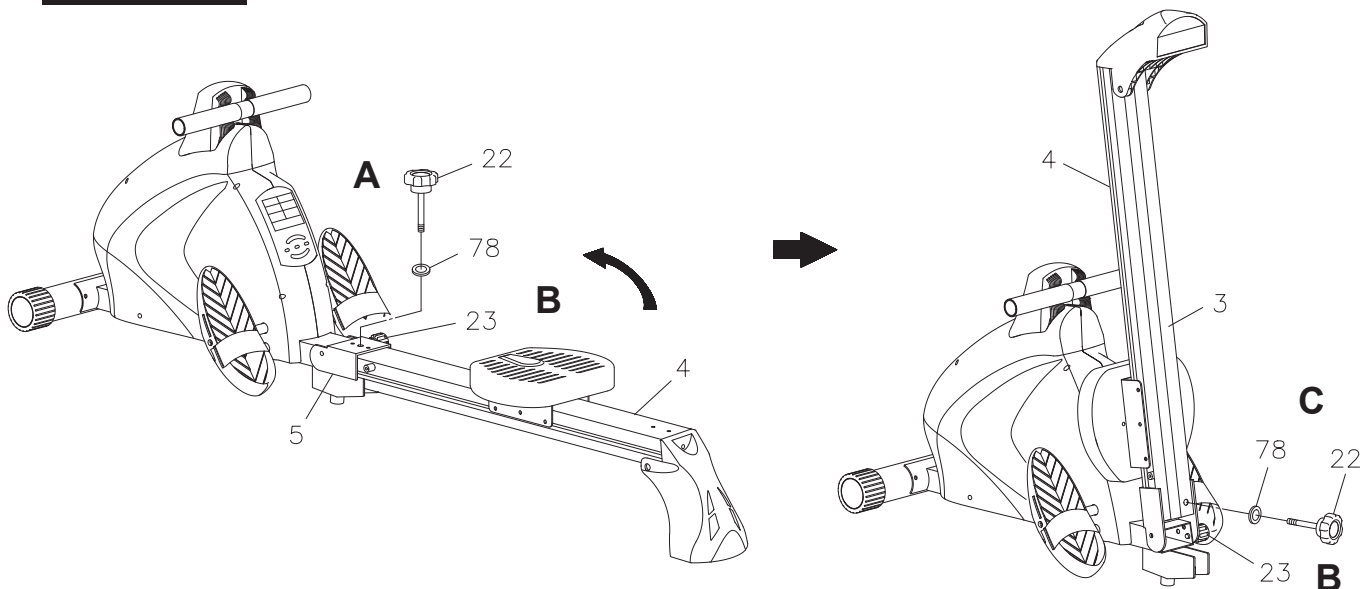

MAINTENANCE

The safety and integrity designed into the **AVARI® Programmable Magnetic Rower** can only be maintained when the **AVARI® Programmable Magnetic Rower** is regularly examined for damage and wear. Special attention should be given to the following:

1. Pull on the **HANDLEBAR(32)** and verify that the Magnetic System provides tension. The Magnetic System should provide many years of use.
2. Clean the roller tracks in the **RAIL(4)** with an absorbent cloth.
3. Verify that all nuts and bolts are present and properly tightened. Replace missing nuts and bolts. Tighten loose nuts and bolts.
4. Verify that the **CAUTION LABEL(86)** is in place and easy to read. Call Stamina Products immediately at **1-800-375-7520** for a replacement **CAUTION LABEL(86)** if it is missing or damaged.
5. It is the sole responsibility of the user/owner to ensure that regular maintenance is performed.
6. Worn or damaged components must be replaced immediately or the **AVARI® Programmable Magnetic Rower** removed from service until repair is made.
7. Only Stamina Products supplied components should be used to maintain/repair the **AVARI® Programmable Magnetic Rower**.
8. Keep your **AVARI® Programmable Magnetic Rower** clean by wiping it off with an absorbent cloth after use.
9. Check the condition of the **STRAP(27)**. Replace the **STRAP(27)** if it is cracked or broken.

CONDITIONING GUIDELINES

How you begin your exercise program depends on your physical condition. If you have been inactive for several years or are severely overweight, start slowly and increase your workout time gradually. Increase your workout intensity gradually by monitoring your heart rate while you exercise.

Remember to follow these essentials:

- Have your doctor review your training and diet programs.
- Begin your training program slowly with realistic goals that have been set by you and your physician.
- Warm up before you exercise and cool down after you work out.
- Take your pulse periodically during your workout and strive to stay within a range of 60% (lower intensity) to 90% (higher intensity) of your maximum heart rate zone. Start at the lower intensity, and build up to higher intensity as you become more aerobically fit.
- If you feel dizzy or lightheaded you should slow down or stop exercising.

Initially you may only be able to exercise within your target zone for a few minutes; however, your aerobic capacity will improve over the next six to eight weeks. It is important to pace yourself while you exercise so you don't tire too quickly.

To determine if you are working out at the correct intensity, use a heart rate monitor or use the table below. For effective aerobic exercise, your heart rate should be maintained at a level between 60% and 90% of your maximum heart rate. If just starting an exercise program, work out at the low end of your target heart rate zone. As your aerobic capacity improves, gradually increase the intensity of your workout by increasing your heart rate.

Measure your heart rate periodically during your workout by stopping the exercise but continuing to move your legs or walk around. Place two or three fingers on your wrist and take a six second heartbeat count. Multiply the results by ten to find your heart rate. For example, if your six second heartbeat count is 14, your heart rate is 140 beats per minute. A six second count is used because your heart rate will drop rapidly when you stop exercising. Adjust the intensity of your exercise until your heart rate is at the proper level.

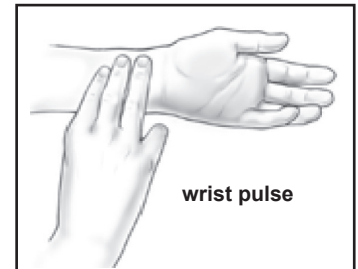

Target Heart Rate Zone Estimated by Age*

Age	Target Heart Rate Zone (55%-90% of Maximum Heart Rate)	Average Maximum Heart Rate 100%
20 years	110-180 beats per minute	200 beats per minute
25 years	107-175 beats per minute	195 beats per minute
30 years	105-171 beats per minute	190 beats per minute
35 years	102-166 beats per minute	185 beats per minute
40 years	99-162 beats per minute	180 beats per minute
45 years	97-157 beats per minute	175 beats per minute
50 years	94-153 beats per minute	170 beats per minute
55 years	91-148 beats per minute	165 beats per minute
60 years	88-144 beats per minute	160 beats per minute
65 years	85-139 beats per minute	155 beats per minute
70 years	83-135 beats per minute	150 beats per minute

* For cardiorespiratory training benefits, the American College of Sports Medicine recommends working out within a heart rate range of 55% to 90% of maximum heart rate. To predict the maximum heart rate, the following formula was used: $220 - \text{Age} = \text{predicted maximum heart rate}$

WARM-UP and COOL-DOWN

Warm-Up The purpose of warming up is to prepare your body for exercise and to minimize injuries. Warm up for two to five minutes before strength training or aerobic exercising. Perform activities that raise your heart rate and warm the working muscles. Activities may include brisk walking, jogging, jumping jacks, jump rope, and running in place

Stretching Stretching while your muscles are warm after a proper warm-up and again after your strength or aerobic training session is very important. Muscles stretch more easily at these times because of their elevated temperature, which greatly reduces the risk of injury. Stretches should be held for 15 to 30 seconds. Do not bounce.

Suggested Stretching Exercises

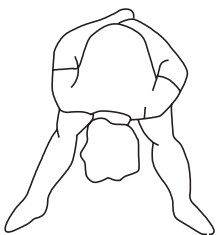

Lower Body Stretch

Place feet shoulder-width apart and lean forward. Keep this position for 30 seconds using the body as a natural weight to stretch the backs of the legs.

DO NOT BOUNCE!

When the pull on the back of the legs lessens, gradually try a lower position.



Floor Stretch

While sitting on the floor, open the legs as wide as possible. Stretch the upper body toward the knee on the right leg by using your arms to pull your chest to your thighs. Hold this stretch 10 to 30 seconds.

DO NOT BOUNCE!

Do this stretch 10 times. Repeat the stretch with the left leg.

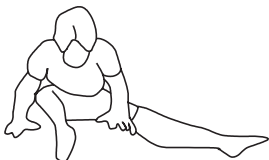

Bent Torso Pulls

While sitting on the floor, have legs apart, one leg straight and one knee bent. Pull the chest down to touch the thigh on the leg that is bent, and twist at the waist. Hold this position at least 10 seconds. Repeat 10 times on each side.



Bent Over Leg Stretch

Stand with feet shoulder-width apart and lean forward as illustrated. Using the arms, **gently** pull the upper body towards the right leg. Let the head hang down. **DO NOT BOUNCE!**

Hold the position a minimum of 10 seconds. Repeat pulling the upper body to the left leg. Do this stretch several times slowly.

Remember to always check with your physician before starting any exercise program.

Cool-Down The purpose of cooling down is to return the body to its normal, or near normal, resting state at the end of each exercise session. A proper cool-down slowly lowers your heart rate and allows blood to return to the heart. Your cool-down should include the stretches listed above and should be completed after each strength training session.

PRODUCT PARTS DRAWING

FRONT

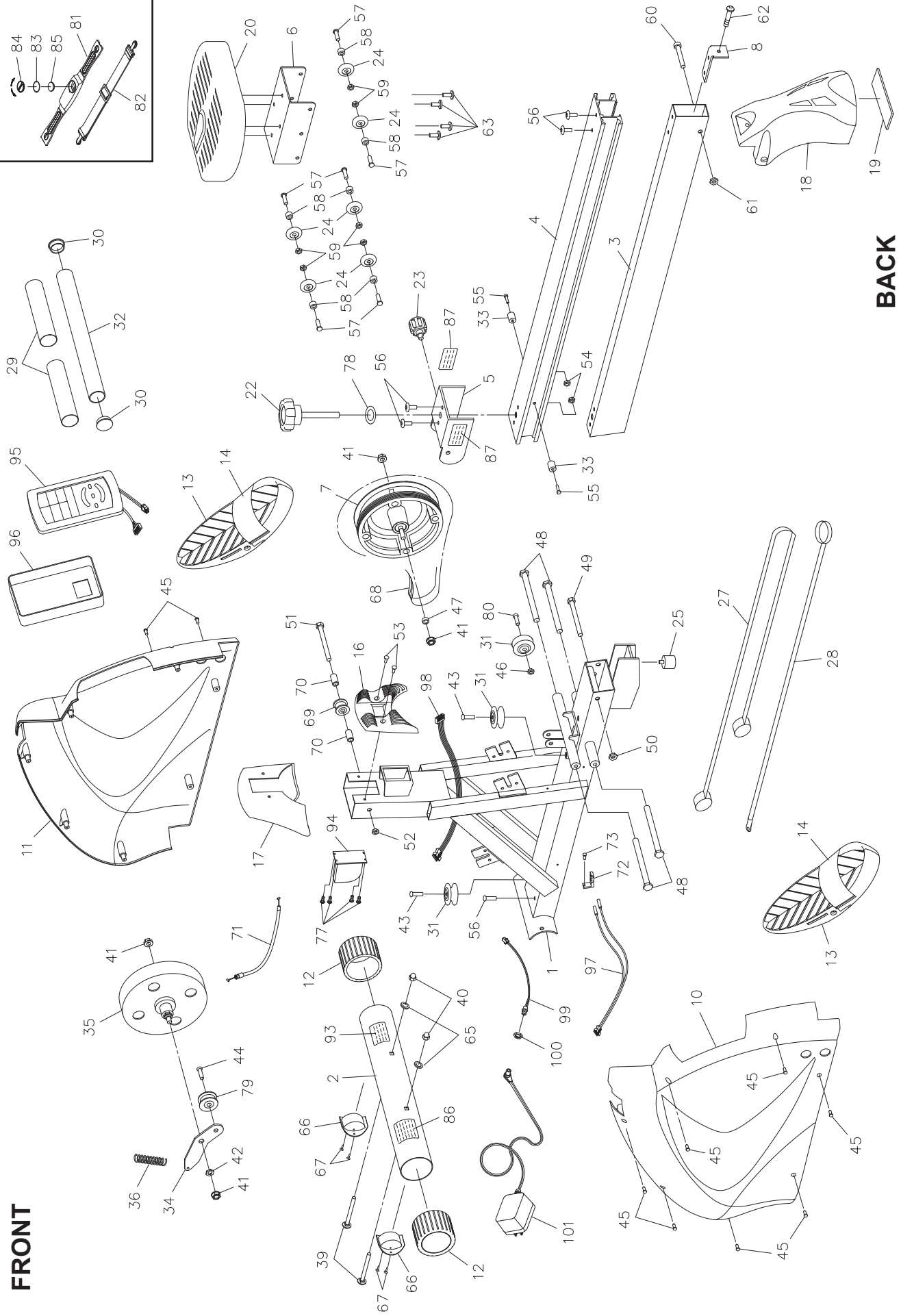
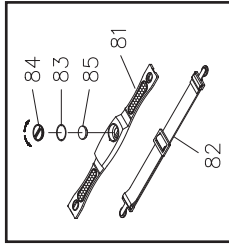

BACK

PARTS LIST

PART#	PART NAME	QTY
1	Main Frame	1
2	Front Stabilizer	1
3	Support Rail	1
4	Rail	1
5	Connecting Bracket	1
6	Seat Carriage	1
7	Pulley	1
8	Fixing Bracket	1
10	Left Cover	1
11	Right Cover	1
12	Endcap (76mm)	2
13	Pedal Cap	2
14	Pedal Strap	2
16	Handlebar Holder	1
17	Top Cover	1
18	Rear Stand	1
19	Stand Pad	1
20	Seat	1
22	Locking Knob	1
23	Spring Knob	1
24	Roller	6
25	Rubber Stand	1
27	Strap	1
28	Bungee Cord	1
29	Foam Grip	2
30	Round Plug (38mm)	2
31	Bungee Wheel	3
32	Handlebar	1
33	Stopper	2
34	Idler Arm	1
35	Magnetic System	1
36	Tension Spring	1
39	Carriage Bolt (M8 x 1.25 x 90mm)	2
40	Acorn Nut (M8 x 1.25)	2
41	Flange Nut (3/8" - 26)	4
42	Thin Nut (3/8"-26, 0.13" thick)	1
43	Bolt, Hex Head (M8 x 1.25 x 35mm)	2
44	Bolt, Button Head (M10 x 1.5 x 20mm)	1
45	Screw, Round Head (M4 x 16mm)	9
46	Nylock Nut (M8 x 1.25)	1
47	Thin Nut (3/8"-26, 0.16" thick)	1
48	Shaft Bolt	4
49	Bolt, Hex Head (3/8"-16 x 4.7")	1
50	Nylock Nut (3/8"-16)	1
51	Bolt, Hex Head (3/8"-16 x 4.13")	1
52	Thin Nylock Nut (3/8"-16 x 0.28" thick)	1
53	Screw, Round Head (M5 x 0.8 x 20mm)	2
54	Nylock Nut (M6 x 1)	2

PARTS LIST

PART#	PART NAME	QTY
55	Bolt, Round Head (M6 x 1 x 25mm)	2
56	Bolt, Button Head (M8 x 1.25 x 20mm)	5
57	Bolt, Button Head (M8 x 1.25 x 27mm)	6
58	Roller Spacer	6
59	Thin Nylock Nut (M8 x 1.25 x 6mm thick)	6
60	Bolt, Button Head (3/8"-16 x 3.54")	1
61	Thin Nylock Nut (3/8"-16 x 0.28" thick, Black Color)	1
62	Bolt, Button Head (M8 x 1.25 x 35mm)	1
63	Bolt, Round Head (M6 x 1 x 12mm)	4
65	Washer (M8)	2
66	Moving Wheel	2
67	Screw, Round Head (M4 x 12mm)	4
68	V-Ribbed Belt	1
69	Strap Roller	1
70	Strap Roller Spacer	2
71	Magnetic Control Cable	1
72	Sensor Holder	1
73	Screw, Round Head (M4 x 16mm)	1
77	Screw, Round Head (M4 x 12mm, Black Color)	4
78	Large Washer (ø13 x ø25 x 2mm thick)	1
79	Idler Wheel	1
80	Bolt, Button Head (M8 x 1.25 x 40mm)	2
81	Heart Rate Transmitter	1
82	Elastic Strap	1
83	Battery Rubber Ring	1
84	Battery Cover	1
85	Button Battery (CR2032)	1
86	Caution Label	1
87	Pinch Point Caution Label	2
88	Allen Wrench (6mm)	1
89	Wrench (14mm)	1
90	Open-End Wrench (14mm)	1
91	Open-End Wrench (21mm)	1
92	Manual	1
93	Serial Decal	1
94	Control Motor	1
95	Computer	1
96	Computer Bottom Cover	1
97	Sensor Wire	1
98	Power Control Cable	1
99	Power Wire	1
100	Plug Nut	1
101	Adapter, Output 9V DC, 500mA	1

LIMITED WARRANTY

MODEL A350-700C

WARRANTY

Stamina Products, Inc. ("Stamina") warrants to the original purchaser that this product will be free from defects in materials and workmanship that arise under normal use, service, proper assembly and proper operation in accordance with product warnings/instructions for a period of 90 days on the parts and three years on the frame from the date of the original purchase from an authorized retailer. **THIS WARRANTY SHALL NOT APPLY TO ANY PRODUCT WHICH HAS BEEN SUBJECT TO COMMERCIAL USE, ABUSE, MISUSE, ALTERATION OF ANY KIND OR TO ANY DEFECT OR CHANGE CAUSED BY IMPROPER ASSEMBLY, REPAIR, REPLACEMENT, SUBSTITUTION OR USE WITH PARTS NOT PROVIDED BY STAMINA.** Commercial use includes use of product in athletic clubs, health clubs, spas, gyms, and all other public or semipublic facilities whether or not the product's use is in furtherance of a profit making enterprise, and all other use which is not for personal purposes.

To implement this limited warranty, send a written notice stating your name, date, and place of purchase and a brief description of the defect along with your receipt to Stamina Products, Inc. 2040 N Alliance Ave, Springfield, Missouri, USA, MO 65803, or email us at customer.care@staminaproducts.com, or call us at 1-800-375-7520. If the defect is covered under this limited warranty, you will be requested to return the product or part to us for free repair or replacement at our option.

NO ACTION FOR BREACH OF THIS LIMITED WARRANTY MAY BE COMMENCED MORE THAN ONE (1) YEAR AFTER THE DATE THE ALLEGED BREACH WAS OR SHOULD HAVE BEEN DISCOVERED. NO ACTION FOR BREACH OF ANY IMPLIED WARRANTY (INCLUDING MERCHANTABILITY AND FITNESS FOR A PARTICULAR PURPOSE) MAY BE COMMENCED MORE THAN ONE (1) YEAR AFTER DELIVERY OF THE PRODUCT TO THE PURCHASER. These warranties are not transferable. **IF ANY PART OF THE PRODUCT IS NOT IN COMPLIANCE WITH THIS LIMITED WARRANTY OR ANY IMPLIED WARRANTY, THE REMEDY OF REPAIR OR REPLACEMENT IS THE EXCLUSIVE REMEDY.** If any claim is made under this limited warranty or any implied warranty, Stamina reserves the right to require the product to be returned for inspection, at the purchaser's expense, to Stamina's premises in Springfield, Missouri. Return of the enclosed warranty registration card is not required for warranty coverage, but is merely a way of establishing the date and place of purchase.

Stamina **SHALL NOT BE LIABLE FOR THE LOSS OF USE OF ANY PRODUCT, LOSS OF TIME, INCONVENIENCE, COMMERCIAL LOSS OR ANY OTHER INDIRECT, CONSEQUENTIAL, SPECIAL OR INCIDENTAL DAMAGES DUE TO BREACH OF THE ABOVE WARRANTY OR ANY IMPLIED WARRANTY.**

THIS LIMITED WARRANTY IS THE ONLY EXPRESS WARRANTY. NO ORAL OR WRITTEN INFORMATION GIVEN BY STAMINA, ITS AGENTS OR EMPLOYEES, SHALL CREATE A WARRANTY OR IN ANY WAY INCREASE THE SCOPE OF THIS WARRANTY. This warranty gives you specific legal rights, and you may also have other legal rights which vary from state to state. **ANY OTHER RIGHT WHICH YOU MAY HAVE, INCLUDING ANY IMPLIED WARRANTY OF MERCHANTABILITY OR FITNESS FOR A PARTICULAR PURPOSE, IS LIMITED IN DURATION TO THE DURATION OF THIS WARRANTY.**

The laws in some states affect the disclaimer or limitation of implied warranties and consequential and incidental damages. If any such law is found applicable, the foregoing disclaimers and limitations of and on implied warranties and consequential and incidental damages shall be deemed to be modified to the extent necessary to comply with applicable law.

NOTES

NOTES

TO CONTACT CUSTOMER CARE

For your convenience, Stamina's customer care representatives can be reached by email at customer.care@staminaproducts.com or by phone at 1-800-375-7520 (in the U.S.). Our customer care representatives are available Monday through Thursday from 7:30 a.m. until 5:00 p.m., and Friday 8:00 a.m. until 3 p.m. Central Time.



**ONLINE
CUSTOMER CARE**
customer.care@staminaproducts.com
www.staminaproducts.com



**TELEPHONE
CUSTOMER CARE**
Tel: 1 (800) 375-7520



**FAX
CUSTOMER CARE**
Fax: (417) 889-8064



MAIL
STAMINA PRODUCTS, INC.
ATTN: Customer Care
2040 N Alliance Ave, Springfield, MO 65803

Would you like to receive email information or special offers from Stamina Products? Register at contact.staminaproducts.com

TO REGISTER YOUR PRODUCT

To enact your warranty, please register your product by going to register.staminaproducts.com. Please have your product model number (printed on the cover of this owner's manual) and the serial number (printed on the black and white sticker on your product) ready.

If you don't have internet access, you can call customer care at 1-800-375-7520, or fill out and mail the product registration form below to Stamina Products, Inc.; 2040 N Alliance Ave, Springfield, MO 65803.

PRODUCT REGISTRATION FORM		Stamina Products, Inc. 2040 N Alliance Ave, Springfield, MO 65803	
Model Number:		Serial Number:	
Product Name:			
Place Purchased:			
Date of Purchase:		Purchase Price:	
First Name:		Last Name:	
City:	State:	Phone #: ()	Zip Code:
Email Address:		Phone #: ()	
Would you like to receive email information or special offers from Stamina Products?* <input type="checkbox"/> Yes <input type="checkbox"/> No *If yes, be sure your email address is included above.			



Detach and Mail or Fax the Form Above



TO ORDER PARTS

If there are missing or damaged parts, you can go to parts.staminaproducts.com and order those parts. If you have questions, please contact customer care. Do not return the product. To order parts by mail, fill out the sheet below and fax it to 417-889-8064. The part will be mailed to your address.



Detach and Mail or Fax the Form Below



PARTS ORDER FORM		Stamina Products, Inc. 2040 N Alliance Ave, Springfield, MO 65803	
Mr./Ms:			
Address:		Apt. #:	
City:	State:	Zip Code:	
IMPORTANT : We require your phone number to process the order!			
Phone #: ()		Work Phone #: ()	
Date of Purchase:			
Model #:			
Purchased From:			
IMPORTANT: Before filling out the portion below, make sure you have the correct information. Refer to the parts list to make sure you're ordering the right parts!			
PART #	DESCRIPTION	QUANTITY	
EXAMPLE: 1	Rear Unit Assembly	1	