

AeroPilates

LESS STRESS | MORE HEART

Precision Pilates Chair

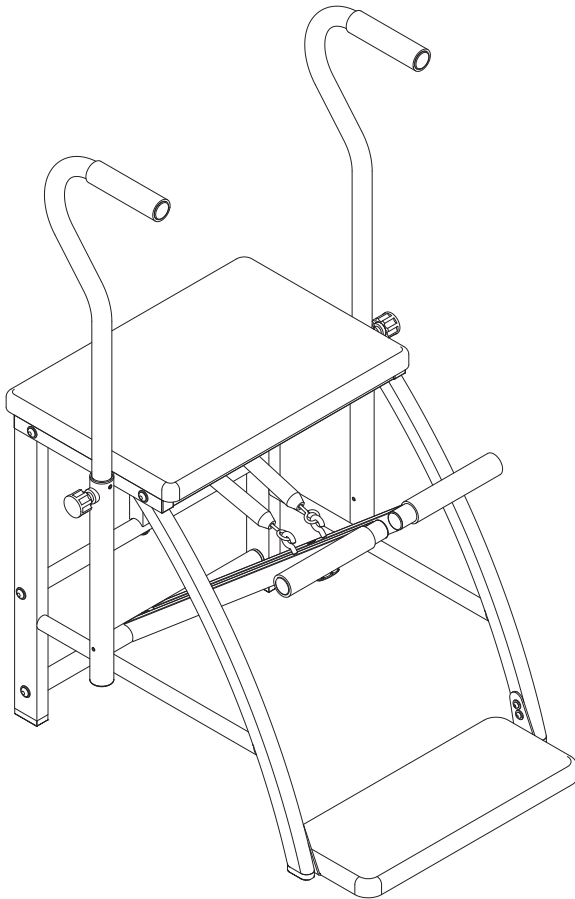

Product May Vary Slightly From Pictured.

CAUTION:

Weight on this product should not exceed 300 lbs.

This Product is Distributed Exclusively by



2040 N Alliance Ave, Springfield, MO 65803

Customer Care

1 (800) 375-7520

www.staminaproducts.com

Owner's Manual

⚠ WARNING

Exercise can present a health risk. Consult a physician before beginning any exercise program with this equipment. If you feel faint or dizzy, immediately discontinue use of this equipment. Serious bodily injury can occur if this equipment is not assembled and used correctly. Serious bodily injury can also occur if all instructions are not followed. Keep others and pets away from equipment when in use. Always make sure all bolts and nuts are securely tightened prior to each use. Follow all safety instructions in this manual.

When calling for parts or service, please specify the following numbers:

Model#: 55-4215

S/N: _____

**STAMINA PRODUCTS
MADE IN CHINA**

© 2019 Stamina Products, Inc.
2020, 01

ACCESS YOUR ONLINE WORKOUT VIDEOS!

How to Access Your Videos

1. Go to video.staminaproducts.com
2. Click 
3. Enter your product VIDEO CODE

*Your **video code** is the model number + serial number. This info can be found on the serial decal.*

**EXAMPLE ONLY. USE MODEL NUMBER + SERIAL NUMBER FROM THE DECAL ON YOUR PRODUCT.*



Coupon Code*

15-033601JAN351450

 REDEEM

Digital product only. No physical DVD will be shipped.

TABLE OF CONTENTS

Safety Instructions	3	Conditioning Guidelines	15
Before You Begin	5	Warm-Up and Cool-Down	16
Equipment Warning, Caution & Notice Labels ...	6	Warranty	17
Hardware Identification Chart	7	Product Parts Drawing	18
Assembly Instructions	8	Parts List	19
Operational Instructions	13	Notes	20
Storage	14	Fax/Mail Ordering Form	22
Maintenance	14		

SAFETY INSTRUCTIONS

⚠ WARNING Cancer and Reproductive Harm www.P65Warnings.ca.gov

⚠ WARNING Consult your physician before starting this or any exercise program. This is especially important if you are over the age of 35, have never exercised before, are pregnant, or suffer from any health problem. Failure to follow all warnings and instructions could result in serious injury or death.

⚠ WARNING To reduce the risk of serious injury, read the following Safety Instructions before using the AeroPilates® Precision Pilates Chair.

1. Save these instructions and ensure that other exercisers read this manual prior to using the **AeroPilates® Precision Pilates Chair** for the first time.
2. Read all warnings and cautions posted on the **AeroPilates® Precision Pilates Chair**.
3. The **AeroPilates® Precision Pilates Chair** should only be used after a thorough review of the Owner's Manual. Make sure that it is properly assembled and tightened before use.
4. We recommend that two people be available for assembly of this product.
5. Keep children away from the **AeroPilates® Precision Pilates Chair**. Do not allow children to use or play on the **AeroPilates® Precision Pilates Chair**. Keep children and pets away from the **AeroPilates® Precision Pilates Chair** at all times.
6. It is recommended that you place this product on an equipment mat.
7. Set up and operate the **AeroPilates® Precision Pilates Chair** on a solid level surface. Do not position the **AeroPilates® Precision Pilates Chair** on loose rugs or uneven surfaces.
8. Make sure that adequate space is available for access to and around the **AeroPilates® Precision Pilates Chair**.
9. Before using, inspect the **AeroPilates® Precision Pilates Chair** for worn or loose components, and securely tighten or replace any worn or loose components prior to use.
10. Consult your physician before using this product. If you feel faint, dizzy, or experience pain during use, stop immediately and consult with your physician.
11. Choose the intensity that fits your strength and flexibility level. Know your body's limits and use this product within them. Use common sense when using this product.
12. Do not wear loose or dangling clothing while using the **AeroPilates® Precision Pilates Chair**.
13. Be careful to maintain your balance while using, mounting, dismounting, or assembling the **AeroPilates® Precision Pilates Chair**, loss of balance may result in a fall and serious bodily injury.
14. The **AeroPilates® Precision Pilates Chair** should not be used by persons weighing over 250 pounds.
15. The **AeroPilates® Precision Pilates Chair** should be used by only one person at a time.

EXTEND YOUR PARTS WARRANTY TO 180 DAYS FROM THE DATE OF PURCHASE. REGISTER YOUR PRODUCT.



**NEED HELP?
CONTACT US FIRST
1 (800) 375-7520
customer.care@staminaproducts.com**

Hi! From all of us here at Stamina Products, thank you for your purchase. We know that you have big fitness goals in mind and we are here to help you along. Call us, email us, or send us a message on Facebook. Be sure to contact us if you have any questions on your new product. We look forward to hearing from you!

With your body in mind,
Stamina Customer Care

To enact your extended warranty and to help us better serve you, please go online and register your new product.

register.staminaproducts.com

It is quick and easy to register online, but if you're a little old school or just need a reason to raise that little flag on your mailbox, fill out the info on the last page of this manual and mail it in.



ONLINE

customer.care@staminaproducts.com
www.staminaproducts.com



TELEPHONE

1 (800) 375-7520



FAX

(417) 889-8064



MAIL

Stamina Products, Inc.
ATTN: Customer Care
2040 N Alliance Ave
Springfield, MO 65803

 facebook.com/StaminaProducts
facebook.com/AeroPilates

CUSTOMER CARE HOURS:
Monday-Thursday, 7:30 AM-5:00 PM, Central Time
Friday, 8:00 AM-3:00 PM, Central Time

BEFORE YOU BEGIN

Thank you for choosing the **AeroPilates® Precision Pilates Chair**. We take great pride in this quality product and hope it will provide many hours of quality exercise to make you feel better, look better, and enjoy life to its fullest.

It's a proven fact that a regular exercise program can improve your physical and mental health. Too often, our busy lifestyles limit our time and opportunity to exercise. The **AeroPilates® Precision Pilates Chair** provides a convenient and simple method to begin your journey of getting your body in shape and achieving a happier and healthier lifestyle.

Before reading further, please review the drawing below and familiarize yourself with the parts that are labeled. Locate the serial decal on the product and write the serial number on the cover of the manual in the space provided. See page 6 for an image of the serial decal. Model number and serial number are required when

calling for assistance.

Read this manual carefully before using the **AeroPilates® Precision Pilates Chair**.

Providing you with a quality product is Stamina's top priority. However, sometimes there could be a missing or incorrectly sized part. If you have any questions or problems with the parts included with your **AeroPilates® Precision Pilates Chair**, please do not return the product. Contact us **FIRST!**

If a part is missing or defective, please contact Customer Care for assistance. Call us toll free at 1-800-375-7520 (in the U.S.) or live chat on staminaproducts.com. Our Customer Care Staff is available to assist you from 7:30 A.M. to 5:00 P.M. (Central Time) Monday through Thursday and 8:00 A.M. to 3:00 P.M. (Central Time) on Friday.

Be sure to have the name and model number of the product available when you contact us.

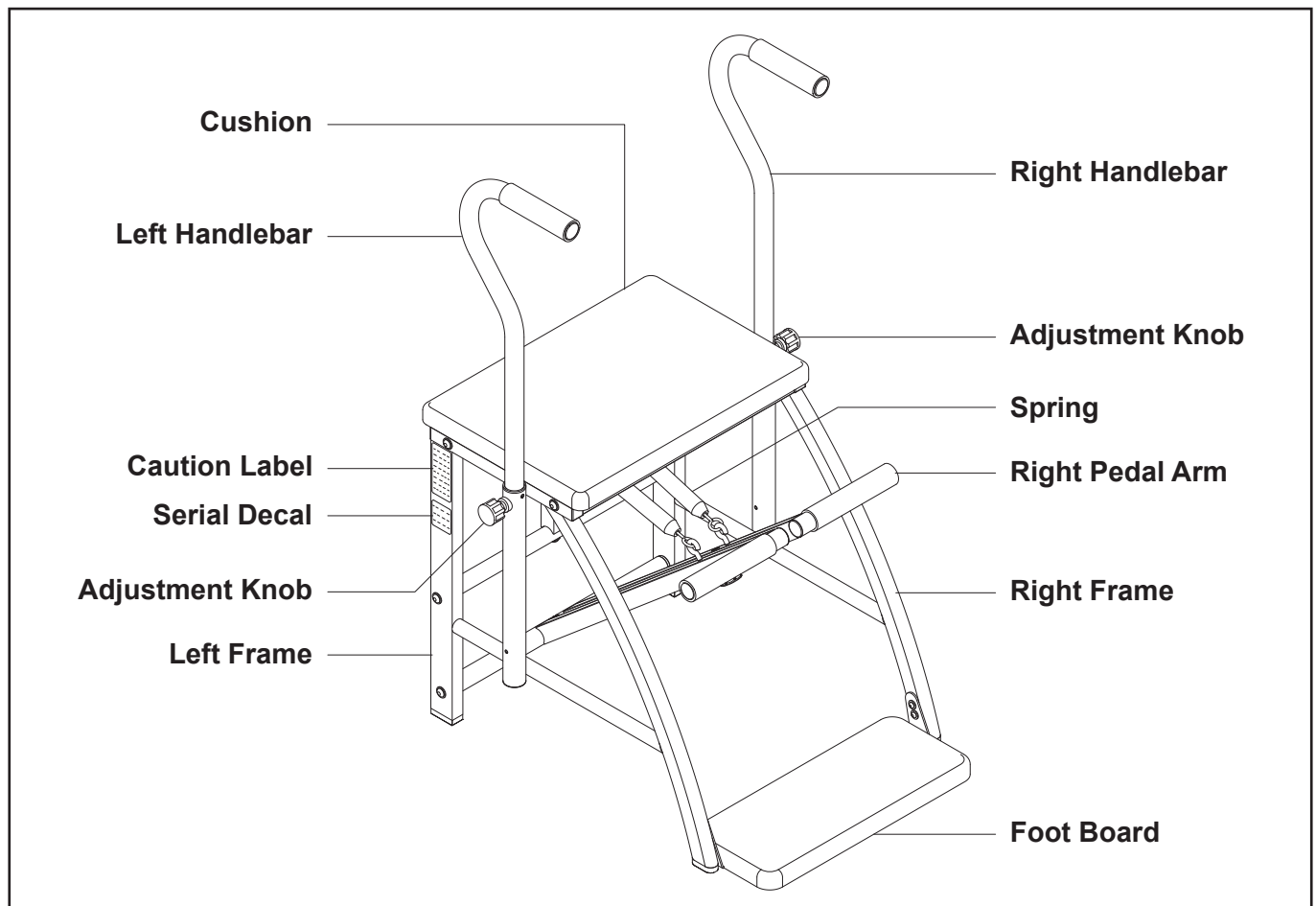

THE FOLLOWING TOOLS ARE INCLUDED FOR ASSEMBLY:

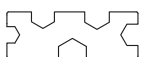

Wrench

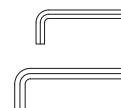

Allen Wrench (4mm)

Allen Wrench (6mm)

EQUIPMENT WARNING, CAUTION & NOTICE LABELS

This chart is provided to help identify the warning, caution, and notice labels on the **AeroPilates® Precision Pilates Chair**. Please take a moment to familiarize yourself with all of the warning, caution, and notice labels.

CAUTION LABEL(41)

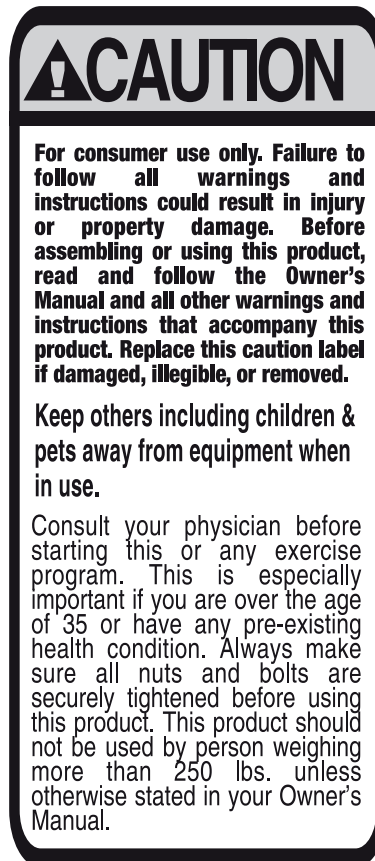

SERIAL DECAL(42)



To best serve you, our Customer Care Representatives will need your serial number. For quick access, write in your serial number on the cover of the manual.

HARDWARE IDENTIFICATION CHART

This chart is provided to help identify the fasteners used in the assembly process. Place the washers or the ends of the bolts or screws on the circles to check for the correct diameter. Use the small scale to check the length of the bolts and screws.

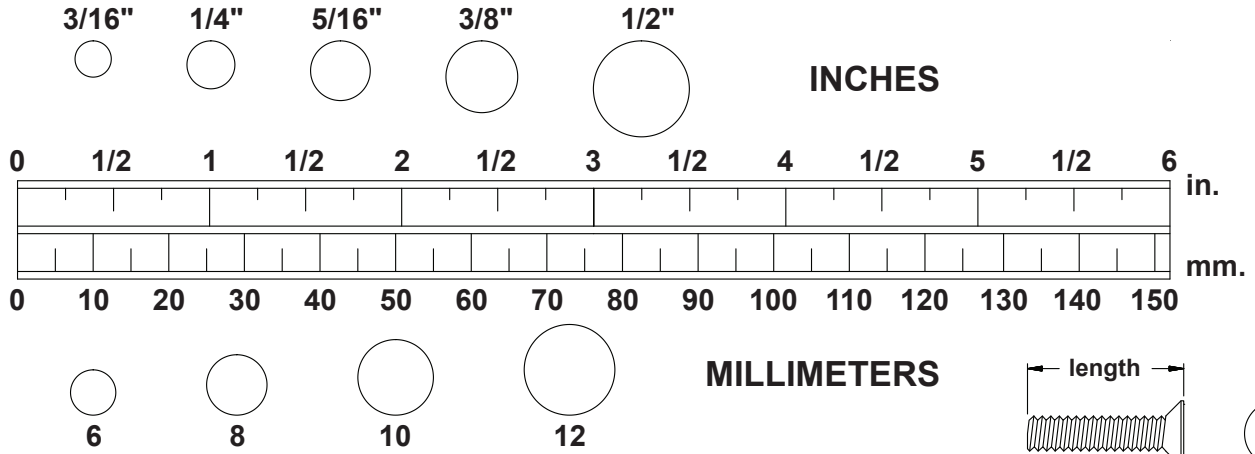

NOTICE: The length of all bolts and screws, except those with flat heads, is measured from below the head to the end of the bolt or screw. Flat head bolts and screws are measured from the top of the head to the end of the bolt or screw.

After unpacking the unit, open the hardware bag and make sure that you have all the following fasteners. Some fasteners may be already attached to the parts.

	Part Number and Description	Qty
	11 Washer (M8)	20
	19 Washer (M6)	4
	34 Plastic Washer (ø32.5 x ø45 x 2mm thick)	1
	12 Arc Washer (M8)	1
	13 Bolt, Button Head (M8 x 1.25 x 70mm)	4
	16 Bolt, Button Head (M8 x 1.25 x 40mm)	4
	17 Bolt, Button Head (M8 x 1.25 x 45mm)	5
	14 Bolt, Button Head (M8 x 1.25 x 20mm)	2
	29 Bolt, Button Head (M6 x 1 x 15mm)	4
	15 Nylock Nut (M8)	6
	18 Bolt, Flat Socket Head (M6 x 1 x 10mm)	4

ASSEMBLY INSTRUCTIONS

Place all parts from the box in a cleared area and position them on the floor in front of you. Remove all packing materials from your area and place them back into the box. Do not dispose of the packing materials until assembly is completed. Read each step carefully before beginning. If you are missing a part, please go to staminaproducts.com under the Customer Care section and order the part needed, e-mail us at customer.care@staminaproducts.com, or call us toll free at 1-800-375-7520 (in the U.S.). Our Customer Care Staff is available to assist you from 7:30 A.M. to 5:00 P.M. (Central Time) Monday through Thursday and 8:00 A.M. to 3:00 P.M. (Central Time) on Friday.

Some product parts are fit tested at the factory to ensure proper fit and alignment. Marks in the paint may be noticeable, but are not an indication of damage.

NOTE: DO NOT SECURELY TIGHTEN ALL BOLTS UNTIL STEP 7.

STEP 1

Attach the **CUSHION FRAME(1)** to the **LEFT FRAME(2)** with **BUTTON HEAD BOLTS(M8x1.25x70mm) (13)**, **NYLOCK NUTS(M8x1.25)(15)**, and **WASHERS(M8)(11)**.

STEP 2

Attach the **PEDAL SHAFT(4)** to the **LEFT FRAME(2)** with **BUTTON HEAD BOLT(M8x1.25x20mm)(14)** and **WASHER(M8)(11)**.

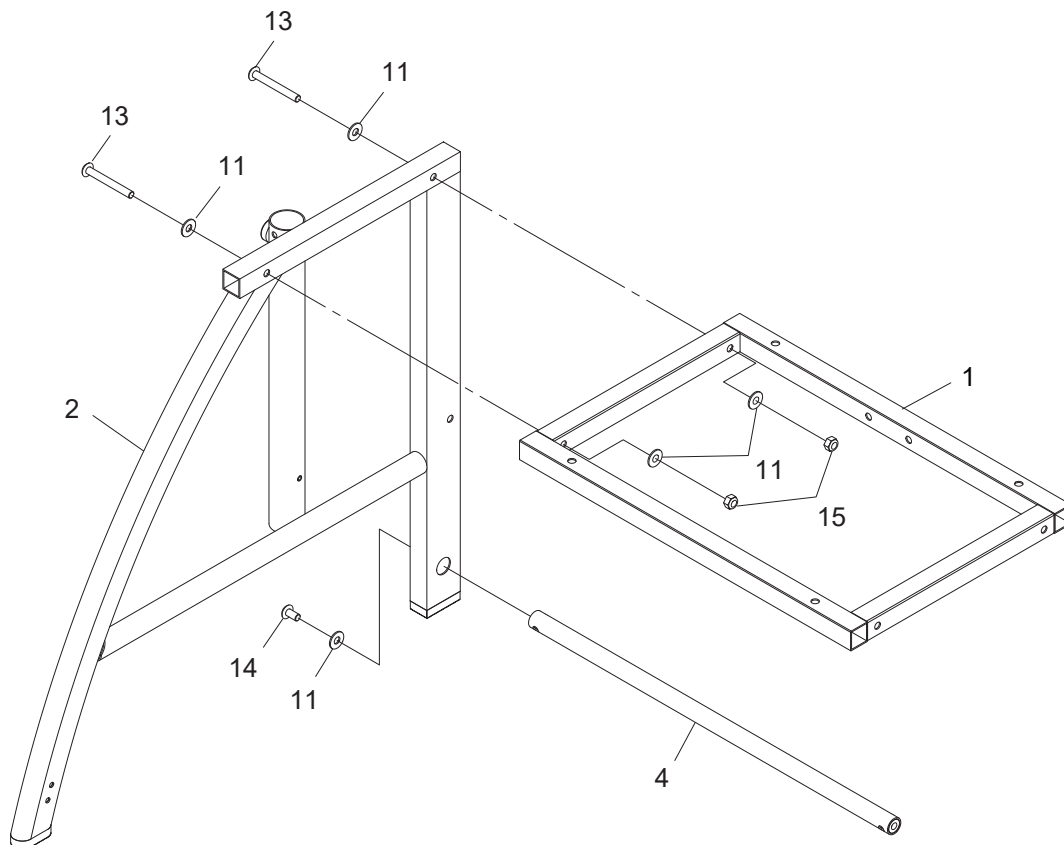

ASSEMBLY INSTRUCTIONS

STEP 3

Insert the **LATCH(37)** into the bracket on the **LEFT PEDAL ARM(33)** and lock in position with the **LOCKING KNOB(36)**. Refer to the illustration. Slide the **LEFT PEDAL ARM(33)**, **PLASTIC WASHER(34)**, and **RIGHT PEDAL ARM(32)** onto the **PEDAL SHAFT(4)**.

STEP 4

Attach the **CUSHION FRAME(1)** to the **RIGHT FRAME(20)** with **BUTTON HEAD BOLTS(M8x1.25x70mm)(13)**, **NYLOCK NUTS(M8x1.25)(15)**, and **WASHERS(M8)(11)**. Attach the **PEDAL SHAFT(4)** to the **RIGHT FRAME(20)** with **BUTTON HEAD BOLT(M8x1.25x20mm)(14)** and **WASHER(M8)(11)**.

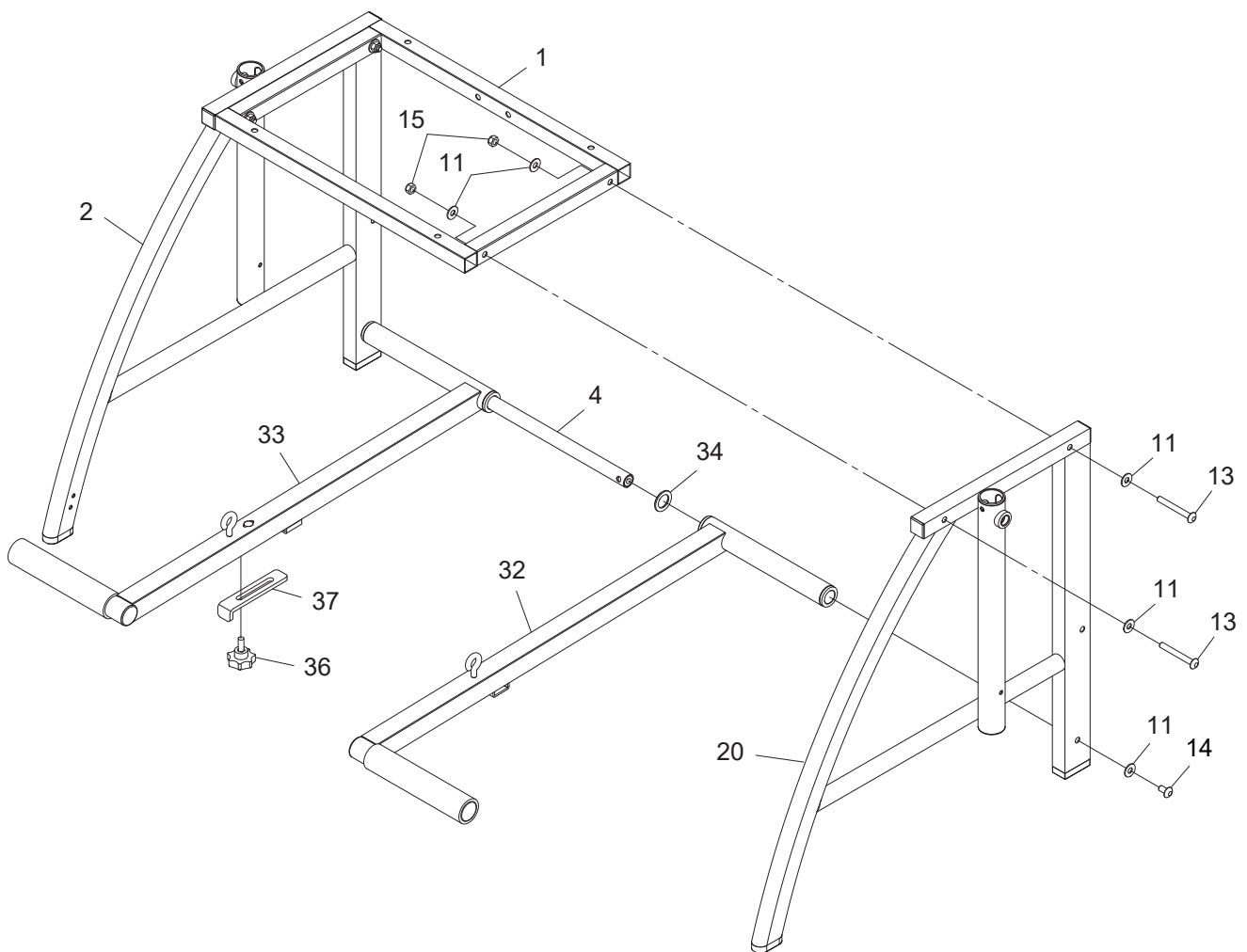

ASSEMBLY INSTRUCTIONS

STEP 5

Slide the **SLIDER(5)** onto the **SPRING SUPPORT(6)** and lock in position with the **ADJUSTMENT KNOB(26)**. Make sure the pin of the **ADJUSTMENT KNOB(26)** catches in one of the adjustment holes of the **SPRING SUPPORT(6)** and tighten the **ADJUSTMENT KNOB(26)**.

STEP 6

Attach the **SPRING SUPPORT(6)** to the **CUSHION FRAME(1)** with **BUTTON HEAD BOLTS (M8x1.25x45mm)(17)**, **NYLOCK NUTS(M8x1.25)(15)**, and **WASHERS(M8)(11)**.

STEP 7

Refer to the illustration. Attach the **CROSSING BAR(7)** to the bottom of the **SPRING SUPPORT(6)** with **BUTTON HEAD BOLT(M8x1.25x45mm)(17)** and **ARC WASHER(M8)(12)**. Attach both ends of the **CROSSING BAR(7)** to the **LEFT** and **RIGHT FRAME(2, 20)** with **BUTTON HEAD BOLTS(M8x1.25x45mm)(17)** and **WASHERS(M8)(11)**.

Securely tighten all of the bolts from STEP 1 to STEP 7.

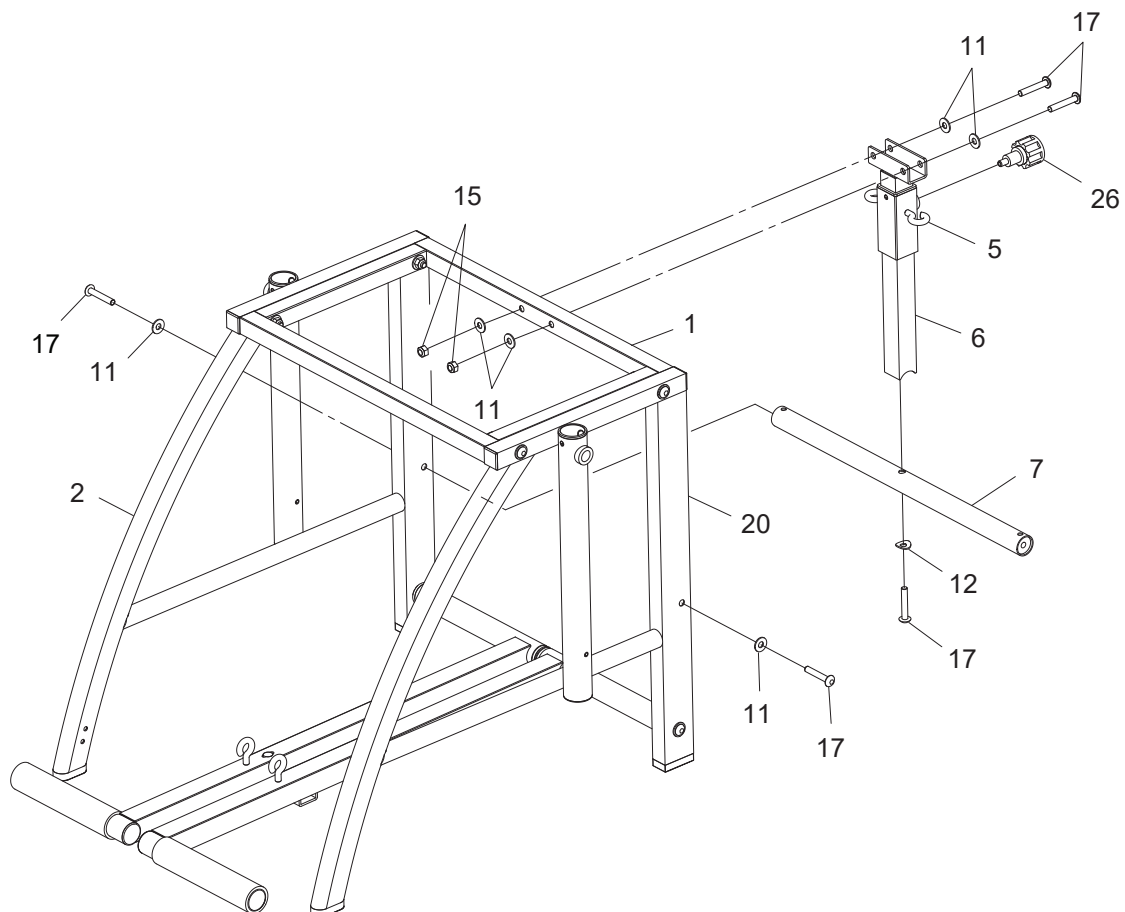

ASSEMBLY INSTRUCTIONS

STEP 8

Attach the **CUSHION(10)** to the **CUSHION FRAME(1)** with **BUTTON HEAD BOLTS(M8x1.25x40mm)(16)** and **WASHERS(M8)(11)**.

STEP 9

Hook a **SPRING(3)** to the hooks on the **RIGHT PEDAL ARM(32)** and the **SLIDER(5)**. Repeat on the left side.

STEP 10

Attach the **LEFT** and **RIGHT BRACKETS(8, 21)** to the bottom of the **FOOT BOARD(9)** with **FLAT SOCKET HEAD BOLTS(M6x1x10mm)(18)**. Install the **FOOT BOARD(9)** by attaching the **LEFT** and **RIGHT BRACKETS(8, 21)** to the **LEFT** and **RIGHT FRAME(2, 20)** with **BUTTON HEAD BOLTS (M6x1x15mm)(29)** and **WASHERS(M6)(19)**.

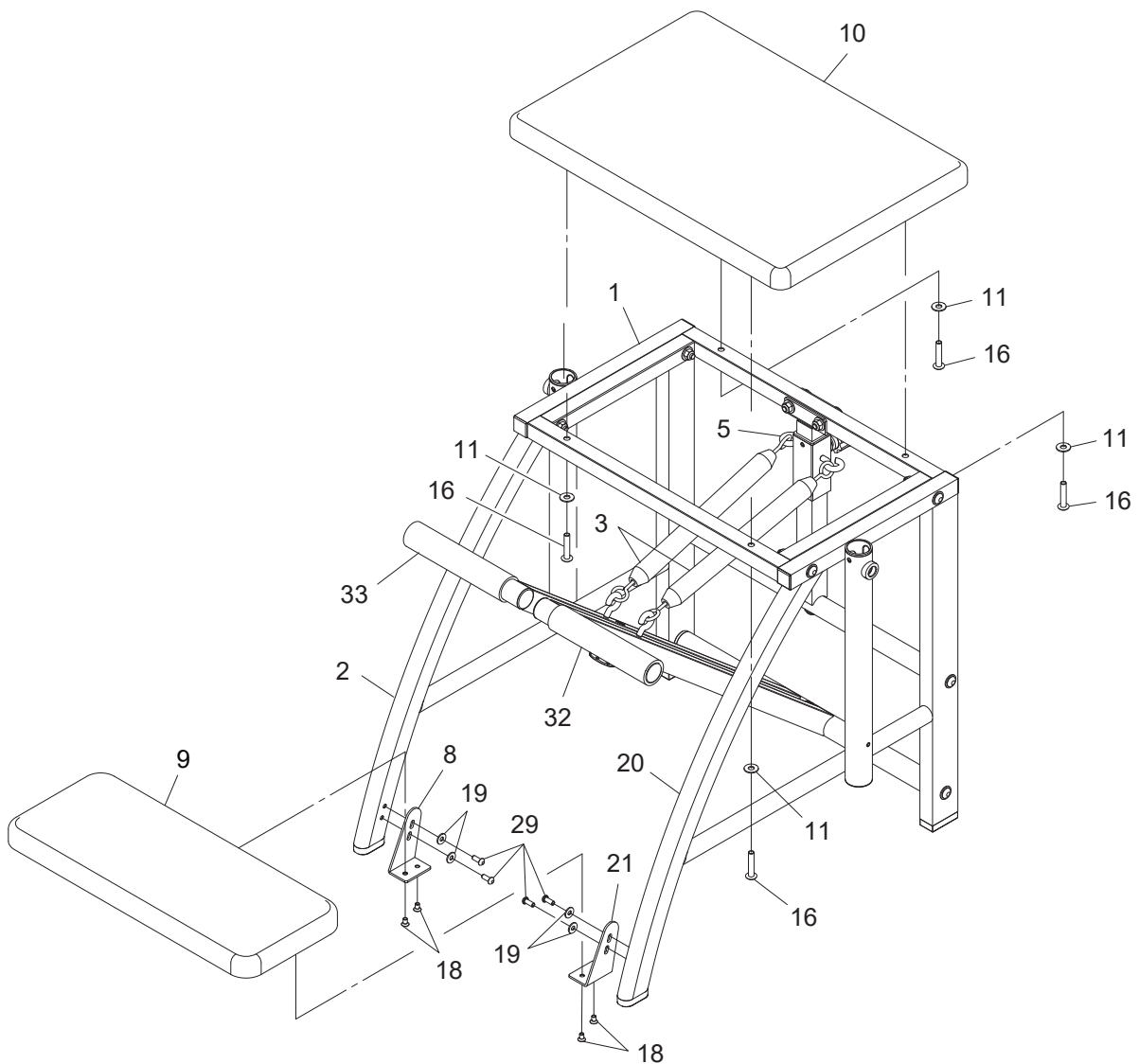

ASSEMBLY INSTRUCTIONS

STEP 11

Insert the **RIGHT HANDLEBAR(31)** into the **RIGHT FRAME(20)** and lock in position with the **ADJUSTMENT KNOB(26)**. Make sure the pin of the **ADJUSTMENT KNOB(26)** catches in one of the adjustment holes of the **RIGHT HANDLEBAR(31)** and tighten the **ADJUSTMENT KNOB(26)**. Repeat on the left side.

To adjust the height of the **HANDLEBARS(30, 31)**, loosen the **ADJUSTMENT KNOB(26)** on the right side, but do not remove, then pull the **ADJUSTMENT KNOB(26)** to release the pin. Slide the **RIGHT HANDLEBAR(31)** up or down to the desired position. Release the **ADJUSTMENT KNOB(26)** making sure the pin catches in one of the holes of the **RIGHT HANDLEBAR(31)**. Always tighten the **ADJUSTMENT KNOB(26)** after adjusting the **RIGHT HANDLEBARS(31)** to a new position. Repeat on the left side, and make both **HANDLEBARS(30, 31)** the same height.

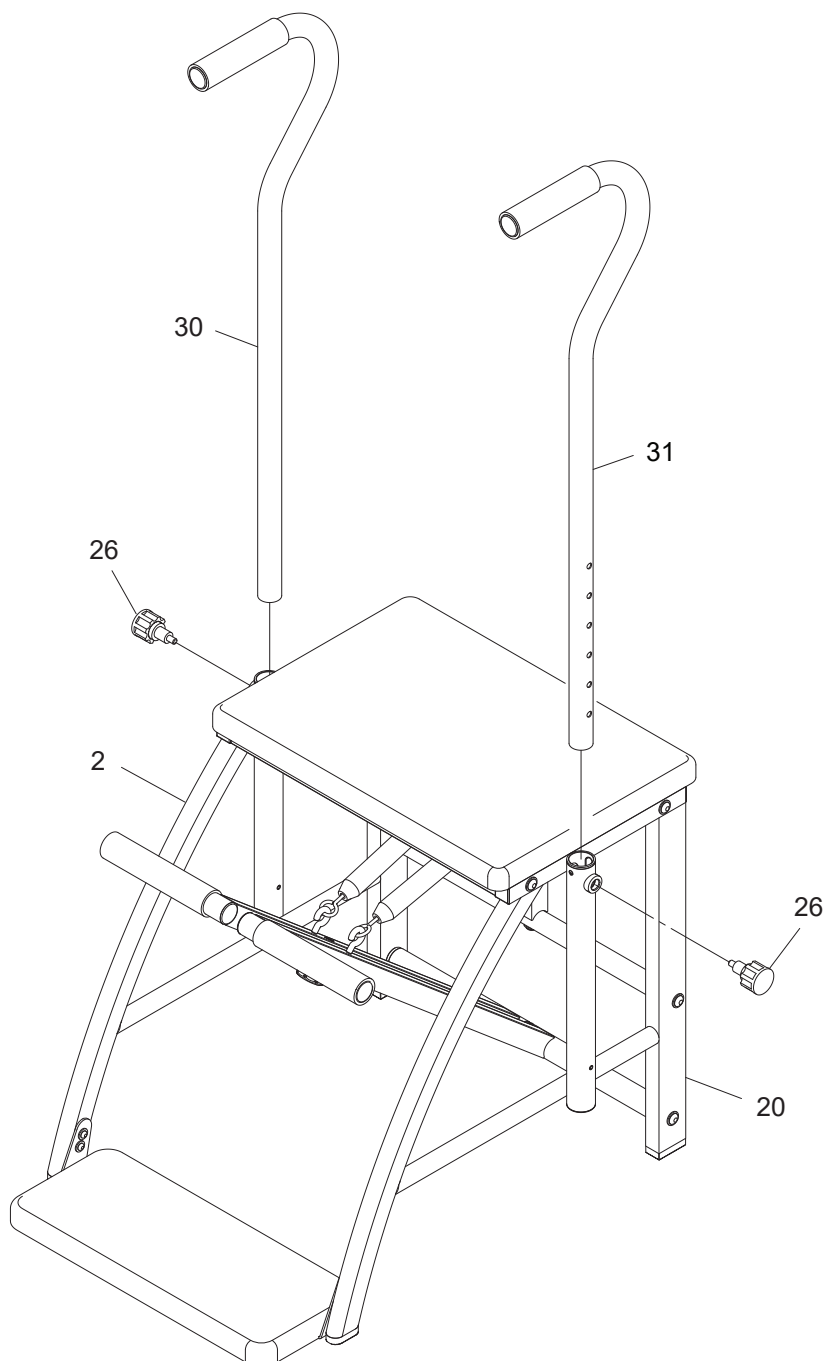

OPERATIONAL INSTRUCTIONS

USING THE AeroPilates® Precision Pilates Chair

The AeroPilates® Precision Pilates Chair can be used without the **HANDLEBARS(30, 31)**. Loosen the **ADJUSTMENT KNOB(26)** on the right side, but do not remove, then pull the **ADJUSTMENT KNOB(26)** to release the pin for removing the **RIGHT HANDLEBAR(31)**. Tighten the **ADJUSTMENT KNOB(26)**. Repeat on the left side.

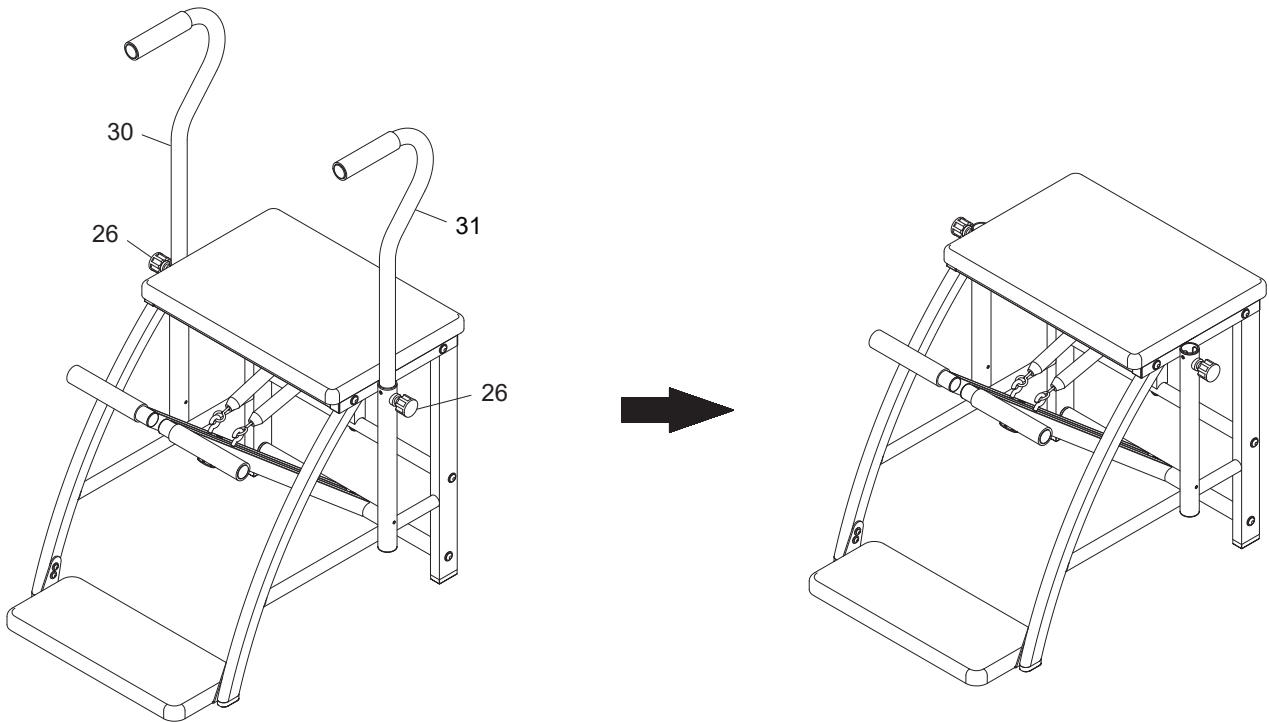

CONNECTING THE PEDAL ARMS

Loosen the **LOCKING KNOB(36)**, but do not remove, then pull the **LATCH(37)** out from the **LEFT PEDAL ARM(33)**. Turn the **LATCH(37)** 90 degrees and insert it into the bracket on the **RIGHT PEDAL ARM(32)**. Tighten the **LOCKING KNOB(36)** to lock the **LATCH(37)** in position. Refer to the detailed view.

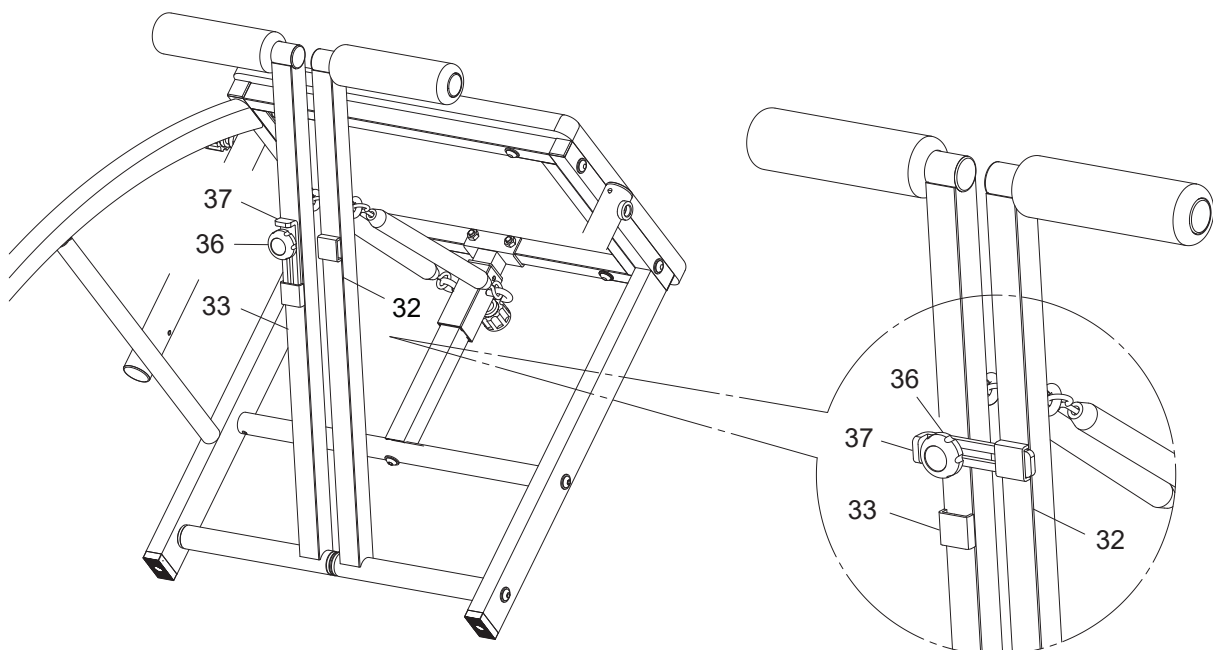

OPERATIONAL INSTRUCTIONS

PEDAL ARM RESISTANCE ADJUSTMENT

Loosen the **ADJUSTMENT KNOB(26)**, but do not remove, then pull the **ADJUSTMENT KNOB(26)** to release the pin. Slide the **SLIDER(5)** up or down to desired position. Release the **ADJUSTMENT KNOB(26)** making sure the pin catches in one of the holes of the **SPRING SUPPORT(6)**. Always tighten the **ADJUSTMENT KNOB(26)** after adjusting the **SLIDER(5)** to a new position.

Move the **SLIDER(5)** to higher position for more spring tension resistance. Move the **SLIDER(5)** to lower position for less spring tension resistance. When the **PEDAL ARMS(32, 33)** are connected you may choose to use only one **SPRING(3)** if less resistance is desired.

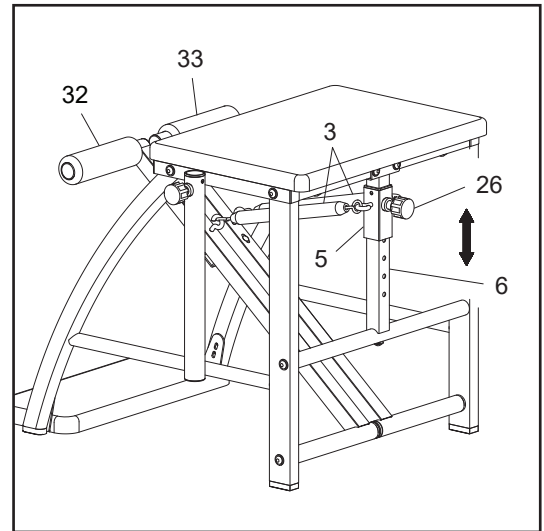

STORAGE

1. To store the **AeroPilates® Precision Pilates Chair**, simply keep it in a clean dry place.
2. It is recommended that two people be available to move the **AeroPilates® Precision Pilates Chair**.
3. Lift from the **LEFT** and **RIGHT FRAMES(2, 20)** to move.

MAINTENANCE

The safety and integrity designed into the **AeroPilates® Precision Pilates Chair** can only be maintained when the **AeroPilates® Precision Pilates Chair** is regularly examined for damage and wear. Special attention should be given to the following:

1. It is the sole responsibility of the user/owner to ensure that regular maintenance is performed.
2. Worn or damaged components must be replaced immediately or the **AeroPilates® Precision Pilates Chair** removed from service until repair is made.
3. Verify that the **CAUTION LABEL(41)** is present and legible. Replace the **CAUTION LABEL(41)** if it is missing or damaged.
4. Check the condition of the **SPRINGS(3)**. Replace the springs that are damaged.
5. Check the **FOAM GRIP(38)** and **HAND GRIP(39)**. Replace if damaged or worn.
6. Check the **CUSHIONS(10)**, replace if any of them is damaged or worn.
7. Only Stamina Products supplied components should be used to maintain/repair the **AeroPilates® Precision Pilates Chair**.
8. Keep your **AeroPilates® Precision Pilates Chair** clean by wiping with an absorbent cloth after use.

CONDITIONING GUIDELINES

How you begin your exercise program depends on your physical condition. If you have been inactive for several years or are severely overweight, start slowly and increase your workout time gradually. Increase your workout intensity gradually by monitoring your heart rate while you exercise.

Remember to follow these essentials:

- Have your doctor review your training and diet programs.
- Begin your training program slowly with realistic goals that have been set by you and your physician.
- Warm up before you exercise and cool down after you work out.
- Take your pulse periodically during your workout and strive to stay within a range of 60% (lower intensity) to 90% (higher intensity) of your maximum heart rate zone. Start at the lower intensity, and build up to higher intensity as you become more aerobically fit.
- If you feel dizzy or lightheaded you should slow down or stop exercising.

Initially you may only be able to exercise within your target zone for a few minutes; however, your aerobic capacity will improve over the next six to eight weeks. It is important to pace yourself while you exercise so you don't tire too quickly.

To determine if you are working out at the correct intensity, use a heart rate monitor or use the table below. For effective aerobic exercise, your heart rate should be maintained at a level between 60% and 90% of your maximum heart rate. If just starting an exercise program, work out at the low end of your target heart rate zone. As your aerobic capacity improves, gradually increase the intensity of your workout by increasing your heart rate.

Measure your heart rate periodically during your workout by stopping the exercise but continuing to move your legs or walk around. Place two or three fingers on your wrist and take a six second heartbeat count. Multiply the results by ten to find your heart rate. For example, if your six second heartbeat count is 14, your heart rate is 140 beats per minute. A six second count is used because your heart rate will drop rapidly when you stop exercising. Adjust the intensity of your exercise until your heart rate is at the proper level.

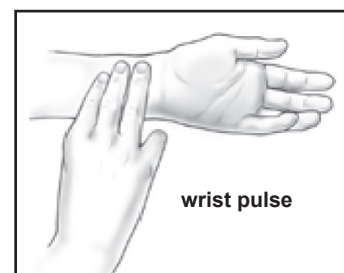

Target Heart Rate Zone Estimated by Age*

Age	Target Heart Rate Zone (55%-90% of Maximum Heart Rate)	Average Maximum Heart Rate 100%
20 years	110-180 beats per minute	200 beats per minute
25 years	107-175 beats per minute	195 beats per minute
30 years	105-171 beats per minute	190 beats per minute
35 years	102-166 beats per minute	185 beats per minute
40 years	99-162 beats per minute	180 beats per minute
45 years	97-157 beats per minute	175 beats per minute
50 years	94-153 beats per minute	170 beats per minute
55 years	91-148 beats per minute	165 beats per minute
60 years	88-144 beats per minute	160 beats per minute
65 years	85-139 beats per minute	155 beats per minute
70 years	83-135 beats per minute	150 beats per minute

* For cardiorespiratory training benefits, the American College of Sports Medicine recommends working out within a heart rate range of 55% to 90% of maximum heart rate. To predict the maximum heart rate, the following formula was used: $220 - \text{Age} = \text{predicted maximum heart rate}$

WARM-UP and COOL-DOWN

Warm-Up The purpose of warming up is to prepare your body for exercise and to minimize injuries. Warm up for two to five minutes before strength training or aerobic exercising. Perform activities that raise your heart rate and warm the working muscles. Activities may include brisk walking, jogging, jumping jacks, jump rope, and running in place.

Stretching Stretching while your muscles are warm after a proper warm-up and again after your strength or aerobic training session is very important. Muscles stretch more easily at these times because of their elevated temperature, which greatly reduces the risk of injury. Stretches should be held for 15 to 30 seconds. Do not bounce.

Suggested Stretching Exercises

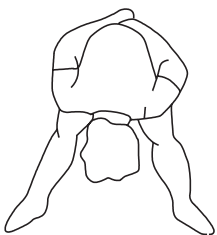

Lower Body Stretch

Place feet shoulder-width apart and lean forward. Keep this position for 30 seconds using the body as a natural weight to stretch the backs of the legs. **DO NOT BOUNCE!** When the pull on the back of the legs lessens, gradually try a lower position.

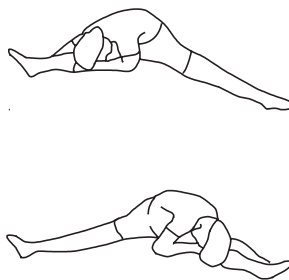

Floor Stretch

While sitting on the floor, open the legs as wide as possible. Stretch the upper body toward the knee on the right leg by using your arms to pull your chest to your thighs. Hold this stretch 10 to 30 seconds. **DO NOT BOUNCE!** Do this stretch 10 times. Repeat the stretch with the left leg.

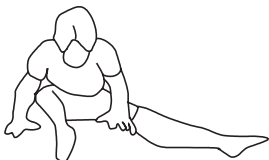

Bent Torso Pulls

While sitting on the floor, have legs apart, one leg straight and one knee bent. Pull the chest down to touch the thigh on the leg that is bent, and twist at the waist. Hold this position at least 10 seconds. Repeat 10 times on each side.

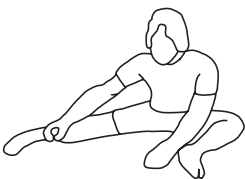

Bent Over Leg Stretch

Stand with feet shoulder-width apart and lean forward as illustrated. Using the arms, **gently** pull the upper body towards the right leg. Let the head hang down. **DO NOT BOUNCE!** Hold the position a minimum of 10 seconds. Repeat pulling the upper body to the left leg. Do this stretch several times slowly.

Remember to always check with your physician before starting any exercise program.

Cool-Down The purpose of cooling down is to return the body to its normal, or near normal, resting state at the end of each exercise session. A proper cool-down slowly lowers your heart rate and allows blood to return to the heart. Your cool-down should include the stretches listed above and should be completed after each strength training session.

LIMITED WARRANTY

MODEL 55-4215

WARRANTY

Stamina Products, Inc. (“Stamina”) warrants to the original purchaser that this product will be free from defects in materials and workmanship that arise under normal use, service, proper assembly and proper operation in accordance with product warnings/instructions for a period of 90 days on the parts and three years on the frame from the date of the original purchase from an authorized retailer. **THIS WARRANTY SHALL NOT APPLY TO ANY PRODUCT WHICH HAS BEEN SUBJECT TO ABUSE, MISUSE, ALTERATION OF ANY KIND OR TO ANY DEFECT OR CHANGE CAUSED BY IMPROPER ASSEMBLY, REPAIR, REPLACEMENT, SUBSTITUTION OR USE WITH PARTS NOT PROVIDED BY STAMINA.**

To implement this limited warranty, send a written notice stating your name, date, and place of purchase and a brief description of the defect along with your receipt to Stamina Products, Inc. 2040 N Alliance Ave, Springfield, Missouri, USA, MO 65803, or email us at customer.care@staminaproducts.com, or call us at 1-800-375-7520. If the defect is covered under this limited warranty, you will be requested to return the product or part to us for free repair or replacement at our option.

NO ACTION FOR BREACH OF THIS LIMITED WARRANTY MAY BE COMMENCED MORE THAN ONE (1) YEAR AFTER THE DATE THE ALLEGED BREACH WAS OR SHOULD HAVE BEEN DISCOVERED. NO ACTION FOR BREACH OF ANY IMPLIED WARRANTY (INCLUDING MERCHANTABILITY AND FITNESS FOR A PARTICULAR PURPOSE) MAY BE COMMENCED MORE THAN ONE (1) YEAR AFTER DELIVERY OF THE PRODUCT TO THE PURCHASER. These warranties are not transferable. **IF ANY PART OF THE PRODUCT IS NOT IN COMPLIANCE WITH THIS LIMITED WARRANTY OR ANY IMPLIED WARRANTY, THE REMEDY OF REPAIR OR REPLACEMENT IS THE EXCLUSIVE REMEDY.** If any claim is made under this limited warranty or any implied warranty, Stamina reserves the right to require the product to be returned for inspection, at the purchaser’s expense, to Stamina’s premises in Springfield, Missouri. Return of the enclosed warranty registration card is not required for warranty coverage, but is merely a way of establishing the date and place of purchase.

Stamina **SHALL NOT BE LIABLE FOR THE LOSS OF USE OF ANY PRODUCT, LOSS OF TIME, INCONVENIENCE, COMMERCIAL LOSS OR ANY OTHER INDIRECT, CONSEQUENTIAL, SPECIAL OR INCIDENTAL DAMAGES DUE TO BREACH OF THE ABOVE WARRANTY OR ANY IMPLIED WARRANTY.**

THIS LIMITED WARRANTY IS THE ONLY EXPRESS WARRANTY. NO ORAL OR WRITTEN INFORMATION GIVEN BY STAMINA, ITS AGENTS OR EMPLOYEES, SHALL CREATE A WARRANTY OR IN ANY WAY INCREASE THE SCOPE OF THIS WARRANTY. This warranty gives you specific legal rights, and you may also have other legal rights which vary from state to state. **ANY OTHER RIGHT WHICH YOU MAY HAVE, INCLUDING ANY IMPLIED WARRANTY OF MERCHANTABILITY OR FITNESS FOR A PARTICULAR PURPOSE, IS LIMITED IN DURATION TO THE DURATION OF THIS WARRANTY.**

The laws in some states affect the disclaimer or limitation of implied warranties and consequential and incidental damages. If any such law is found applicable, the foregoing disclaimers and limitations of and on implied warranties and consequential and incidental damages shall be deemed to be modified to the extent necessary to comply with applicable law.

PRODUCT PARTS DRAWING

FRONT

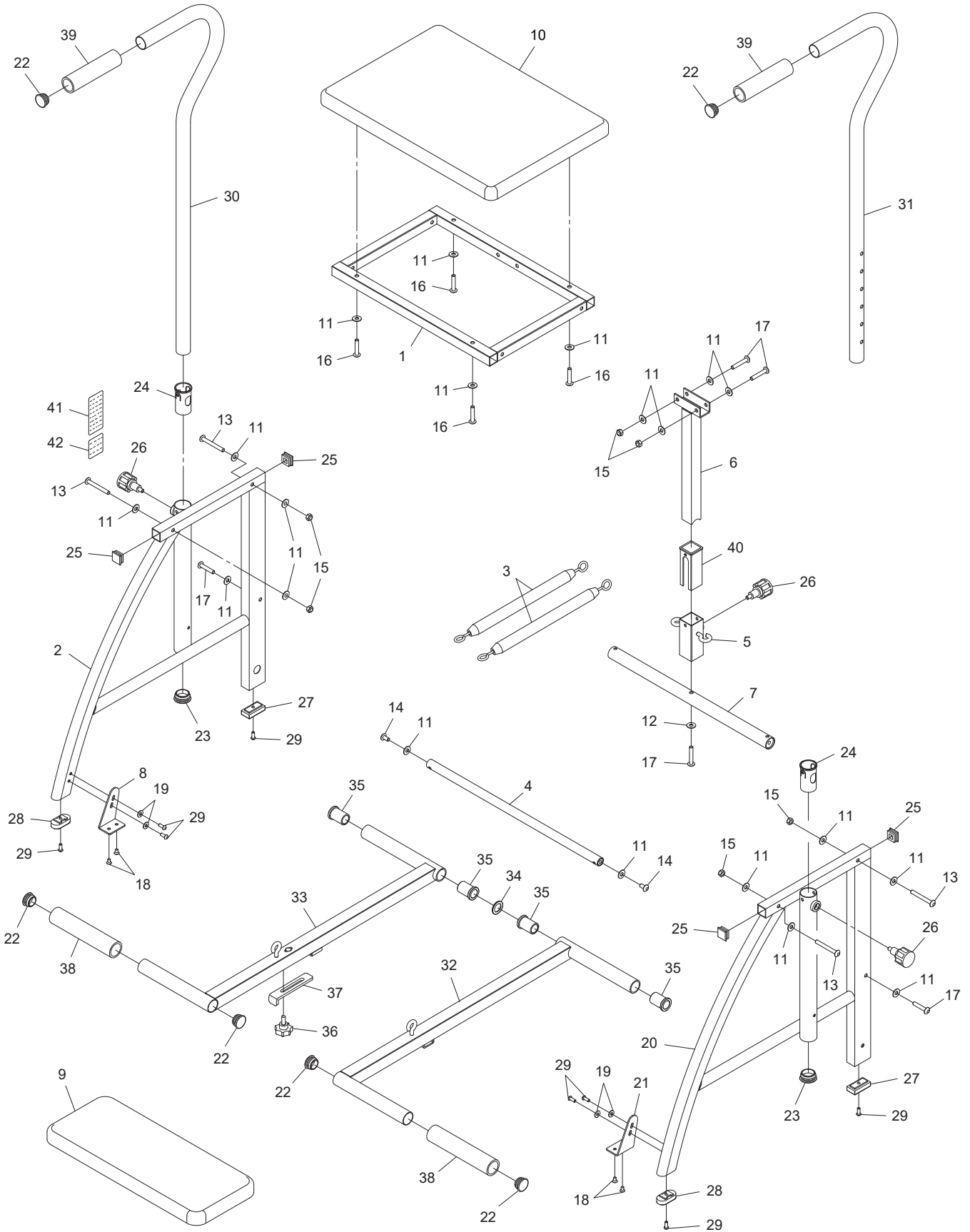

BACK

PARTS LIST

PART#	PART NAME	QTY
1	Cushion Frame	1
2	Left Frame	1
3	Spring	2
4	Pedal Shaft	1
5	Slider	1
6	Spring Support	1
7	Crossing Bar	1
8	Left Bracket	1
9	Foot Board	1
10	Cushion	1
11	Washer (M8)	20
12	Arc Washer (M8)	1
13	Bolt, Button Head (M8 x 1.25 x 70mm)	4
14	Bolt, Button Head (M8 x 1.25 x 20mm)	2
15	Nylock Nut (M8 x 1.25)	6
16	Bolt, Button Head (M8 x 1.25 x 40mm)	4
17	Bolt, Button Head (M8 x 1.25 x 45mm)	5
18	Bolt, Flat Socket Head (M6 x 1 x 10mm)	4
19	Washer (M6)	4
20	Right Frame	1
21	Right Bracket	1
22	Round Plug (31.8mm)	6
23	Round Plug (38.1mm)	2
24	Bushing	2
25	Square Plug (25.4mm x 25.4mm)	4
26	Adjustment Knob	3
27	Stand	2
28	Oval Stand	2
29	Bolt, Button Head (M6 x 1 x 15mm)	8
30	Left Handlebar	1
31	Right Handlebar	1
32	Right Pedal Arm	1
33	Left Pedal Arm	1
34	Plastic Washer (ø32.5 x ø45 x 2mm thick)	1
35	Pedal Arm Bushing	4
36	Locking Knob	1
37	Latch	1
38	Foam Grip (ø31 x ø39 x 189mm)	2
39	Hand Grip (ø31 x ø39 x 150mm)	2
40	Sleeve	1
41	Caution Label	1
42	Serial Decal	1
43	Wrench	1
44	Allen Wrench(4mm)	1
45	Allen Wrench(6mm)	1
46	Manual	1

NOTES

NOTES

TO CONTACT CUSTOMER CARE

For your convenience, Stamina's customer care representatives can be reached by email at customer.care@staminaproducts.com or by phone at 1-800-375-7520 (in the U.S.). Our customer care representatives are available Monday through Thursday from 7:30 a.m. until 5:00 p.m., and Friday 8:00 a.m. until 3 p.m. Central Time.



**ONLINE
CUSTOMER CARE**
customer.care@staminaproducts.com
www.staminaproducts.com



**TELEPHONE
CUSTOMER CARE**
Tel: 1 (800) 375-7520



**FAX
CUSTOMER CARE**
Fax: (417) 889-8064



MAIL
STAMINA PRODUCTS, INC.
ATTN: Customer Care
2040 N Alliance Ave, Springfield, MO 65803

Would you like to receive email information or special offers from Stamina Products? Register at contact.staminaproducts.com

TO REGISTER YOUR PRODUCT

To enact your warranty, please register your product by going to register.staminaproducts.com. Please have your product model number (printed on the cover of this owner's manual) and the serial number (printed on the black and white sticker on your product) ready.

If you don't have internet access, you can call customer care at 1-800-375-7520, or fill out and mail the product registration form below to Stamina Products, Inc.; 2040 N Alliance Ave, Springfield, MO 65803.

PRODUCT REGISTRATION FORM		Stamina Products, Inc. 2040 N Alliance Ave, Springfield, MO 65803	
Model Number:		Serial Number:	
Product Name:			
Place Purchased:			
Date of Purchase:		Purchase Price:	
First Name:		Last Name:	
City:	State:	Phone #: ()	Zip Code:
Email Address:		Phone #: ()	
Would you like to receive email information or special offers from Stamina Products?* <input type="checkbox"/> Yes <input type="checkbox"/> No *If yes, be sure your email address is included above.			



Detach and Mail or Fax the Form Above



TO ORDER PARTS

If there are missing or damaged parts, you can go to parts.staminaproducts.com and order those parts. If you have questions, please contact customer care. Do not return the product. To order parts by mail, fill out the sheet below and fax it to 417-889-8064. The part will be mailed to your address.



Detach and Mail or Fax the Form Below



PARTS ORDER FORM		Stamina Products, Inc. 2040 N Alliance Ave, Springfield, MO 65803	
Mr./Ms:			
Address:		Apt. #:	
City:	State:	Zip Code:	
IMPORTANT : We require your phone number to process the order!			
Phone #: ()		Work Phone #: ()	
Date of Purchase:			
Model #:			
Purchased From:			
IMPORTANT: Before filling out the portion below, make sure you have the correct information. Refer to the parts list to make sure you're ordering the right parts!			
PART #	DESCRIPTION	QUANTITY	
EXAMPLE: 1	Rear Unit Assembly	1	