

AeroPilates®

STAND FOR **MEDIUM** REFORMERS

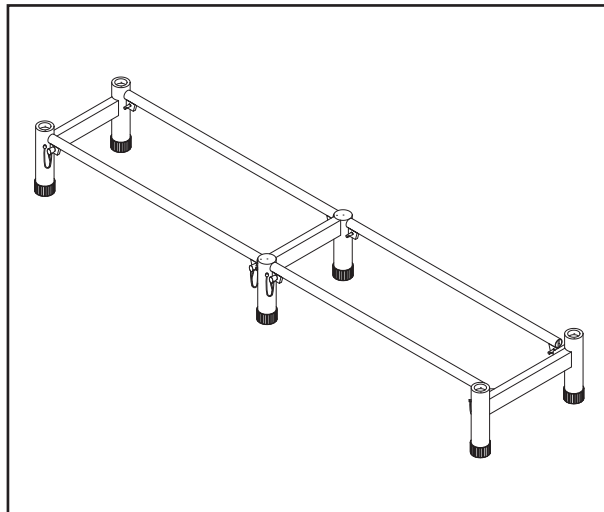

SAFETY INSTRUCTIONS

- ⚠ WARNING** Cancer and Reproductive Harm
www.P65Warnings.ca.gov
- ⚠ WARNING** Consult your physician before starting this or any exercise program. This is especially important if you are over the age of 35, have never exercised before, are pregnant, or suffer from any health problem. This product is for home use only. Do not use in institutional or commercial applications. Failure to follow all warnings and instructions could result in serious injury or death.
- ⚠ WARNING** To reduce the risk of serious injury, read the following Safety Instructions before using the AeroPilates® Stand.

1. The **AeroPilates® Stand** is designed to elevate the medium frame **AeroPilates®** reformers.
2. Save these instructions and ensure that other exercisers read this manual prior to using the **AeroPilates® Stand** for the first time.
3. The **AeroPilates® Stand** should only be used after a thorough review of this instruction sheet and a review of the safety instructions provided with your **AeroPilates®** reformer. Make sure that it is properly assembled and tightened before use.
4. When exercising with this product, do not exercise at an intensity that causes the product itself to move. This could result in damage to your joints and to the product.
5. Keep children away from the **AeroPilates® Stand**. Do not allow children to use or play on the **AeroPilates® Stand**. Keep children and pets away from the **AeroPilates® Stand** when it is in use.
6. When using the **AeroPilates® Stand**, place your **AeroPilates®** reformer on a solid level surface. Do not position it on loose rugs or uneven surfaces.
7. Make sure that adequate space is available for access to and around your **AeroPilates®** reformer when using the **AeroPilates® Stand**.
8. Before using, inspect the **AeroPilates® Stand** for worn or loose components, and tighten or replace any worn or loose components prior to use.
9. Consult a physician prior to commencing an exercise program and follow his/her recommendations in developing your fitness program. If at any time during exercise you feel faint, dizzy, or experience pain, stop and consult your physician.
10. Always choose the workout which best fits your physical strength and flexibility level. Know your limits and train within them. Always use common sense when exercising.
11. Do not wear loose or dangling clothing while using your **AeroPilates®** reformer.
12. Be careful to maintain your balance while using, mounting, dismounting your **AeroPilates®** reformer, and while assembling the **AeroPilates® Stand**. Loss of balance may result in a fall and bodily injury.
13. The **AeroPilates® Stand** should be used by only one person at a time.
14. The **AeroPilates® Stand** should not be used for any purpose other than its intended use.
15. The **AeroPilates® Stand** is for consumer use only. It is not for use in public or semipublic facilities.

This Product is Distributed Exclusively by



2040 N Alliance Ave, Springfield, MO 65803

Customer Care

1 (800) 375-7520

customer.care@staminaproducts.com

www.staminaproducts.com

When calling for parts or service, please specify the following number:

Model# 55-4050A

MADE IN CHINA

© 2019 Stamina Products, Inc.

2019, 03

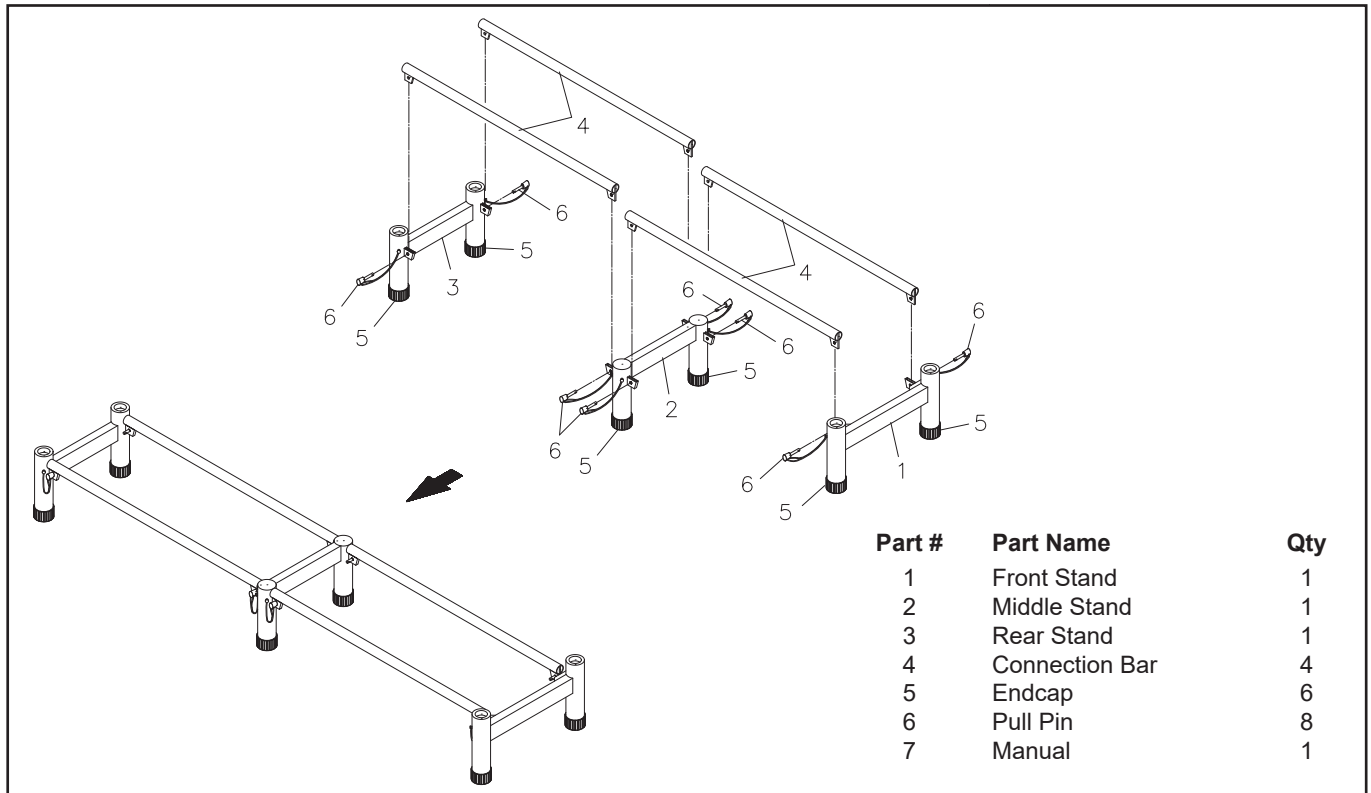

Assembly of The AeroPilates® Stand

Refer to the illustration above. Connect the **FRONT STAND(1)** to the **MIDDLE STAND(2)** with two **CONNECTION BARS(4)** and lock in the place with the **PULL PINS(6)**. Repeat to connect the **REAR STAND(3)** to the **MIDDLE STAND(2)**.

The **AeroPilates® Stand** is designed to elevate the medium frame **AeroPilates®** reformers. Place your **AeroPilates®** reformer onto the **AeroPilates® Stand** as shown in the illustration.

NOTE:

The feet of the **AeroPilates®** reformers must fit into the **FRONT STAND(1)** and the **REAR STAND(3)**. The **FRONT STAND(1)** is wider than the **REAR STAND(3)**. The Foot Rest end of your **AeroPilates®** reformer will fit into the top of the **FRONT STAND(1)** and the Headrest end of your **AeroPilates®** reformer will fit into the **REAR STAND(3)**.

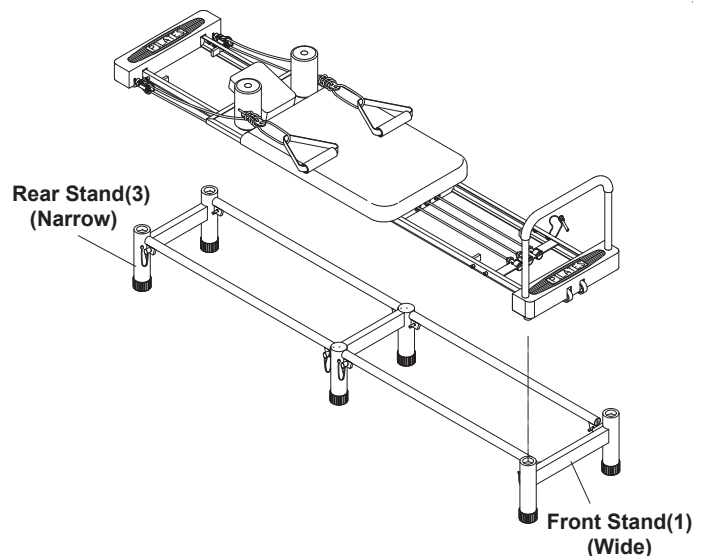

LIMITED WARRANTY

This product is warranted to be free from defects in material and workmanship and to be in perfect working order at the time of purchase. This warranty applies to personal, family or household use. This warranty does not apply to use in athletic clubs, health clubs, spas, gymnasiums, exercise facilities, and other public or semipublic facilities.

If the product should, for any reason, become defective within 90 days of purchase, the manufacturer will replace the product once it is returned to the manufacturer. This warranty does not apply to any damage caused by accident, return transit, improper assembly, alteration, abuse, or misuse. There are no other warranties other than those expressly set forth herein.

Products shipped to the manufacturer must be in the original shipping carton with freight prepaid. All expenses for repairing or replacing the product, including the cost of shipping it back to the original purchaser, will be covered by the manufacturer. This warranty gives you specific legal rights, and you may have other rights which vary from state to state.