

AeroPilates® Cardio Rebounder

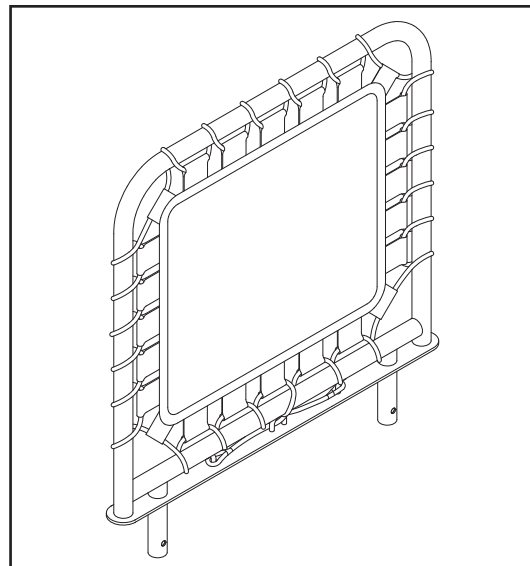

SAFETY INSTRUCTIONS

- ⚠ WARNING** Cancer and Reproductive Harm www.P65Warnings.ca.gov
- ⚠ CAUTION** The Bungee Cord(3) contain natural rubber latex which may cause allergic reactions.
- ⚠ WARNING** Consult your physician before starting this or any exercise program. This is especially important if you are over the age of 35, have never exercised before, are pregnant, or suffer from any health problem. This product is for home use only. Do not use in institutional or commercial applications. Failure to follow all warnings and instructions could result in bodily injury and property damage.
- ⚠ WARNING** To reduce the risk of serious injury, read the following Safety Instructions before using the AeroPilates® Cardio Rebounder.

1. The **AeroPilates® Cardio Rebounder** can be added to the Stamina **AeroPilates®** reformers that have the narrow Front Frame which with three or four Tension Cords.
2. Save these instructions and ensure that other exercisers read this manual prior to using the **AeroPilates® Cardio Rebounder** for the first time.
3. The **AeroPilates® Cardio Rebounder** should only be used after a thorough review of this instruction sheet. Make sure that it is properly assembled and tightened before use.
4. When exercising with this product, do not exercise at an intensity that causes the product itself to move. This could result in damage to your joints and to the product.
5. Keep children away from the **AeroPilates® Cardio Rebounder**. Do not allow children to use or play on the **AeroPilates® Cardio Rebounder**. Keep children and pets away from the **AeroPilates® Cardio Rebounder** when it is in use.
6. When using the **AeroPilates® Cardio Rebounder**, place your **AeroPilates®** reformer on a solid level surface. Do not position it on loose rugs or uneven surfaces.
7. Make sure that adequate space is available for access to and around your **AeroPilates®** reformer when using the **AeroPilates® Cardio Rebounder**.
8. Before using, inspect the **AeroPilates® Cardio Rebounder** for worn or loose components, and tighten or replace any worn or loose components prior to use.
9. Consult a physician prior to commencing an exercise program and follow his/her recommendations in developing your fitness program. If at any time during exercise you feel faint, dizzy, or experience pain, stop and consult your physician.
10. Always choose the workout which best fits your physical strength and flexibility level. Know your limits and train within them. Always use common sense when exercising.
11. Do not wear loose or dangling clothing while using your **AeroPilates®** reformer.
12. Be careful to maintain your balance while using, mounting, dismounting your **AeroPilates®** reformer, and while assembling the **AeroPilates® Cardio Rebounder**. Loss of balance may result in a fall and bodily injury.
13. The **AeroPilates® Cardio Rebounder** should be used by only one person at a time.
14. The **AeroPilates® Cardio Rebounder** is for consumer use only. It is not for use in public or semipublic facilities.

This Product is Distributed Exclusively by



2040 N Alliance Ave, Springfield, MO 65803

Customer Care

1 (800) 375-7520

customer.care@staminaproducts.com

www.staminaproducts.com

When calling for parts or service, please specify the following number:

Model# 55-0011B

MADE IN CHINA

© 2018 Stamina Products, Inc.

2018, 11

ACCESS YOUR ONLINE WORKOUT VIDEOS!

How to Access Your Videos

1. Go to video.staminaproducts.com
2. Click 
3. Enter your product VIDEO CODE

*Your **video code** is the model number + serial number. This info can be found on the serial decal.*

**EXAMPLE ONLY. USE MODEL NUMBER + SERIAL NUMBER FROM THE DECAL ON YOUR PRODUCT.*



Coupon Code*

15-033601JAN351450

REDEEM

Digital product only. No physical DVD will be shipped.

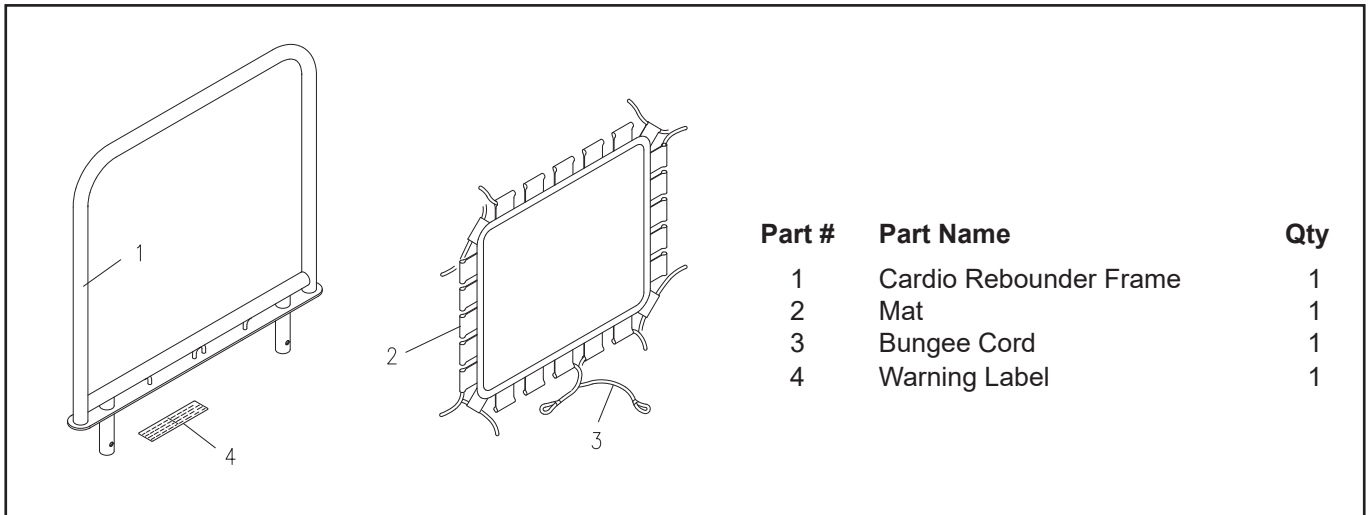

NOTE: Verify that the **WARNING LABEL(4)** is in place and easy to read. Call Stamina Products immediately at **1-800-375-7520** for a replacement **WARNING LABEL(4)** if it is missing or damaged.

Using The AeroPilates® Cardio Rebounder

Make sure that the threaded holes in the **CARDIO REBOUNDER FRAME(1)** are facing toward the front end of the **AeroPilates®** reformer as shown in the illustration. Insert the **CARDIO REBOUNDER FRAME(1)** into the mounting holes located in the **FRONT COVER** and **FRONT FRAME**. Insert the **CARDIO REBOUNDER FRAME(1)** all the way to the bottom and lock it in place with the **LOCKING KNOBS**.

NOTE: Some of the **AeroPilates®** reformers may not include the **LOCKING KNOBS**, just insert the **CARDIO REBOUNDER FRAME(1)** into the **FRONT FRAME** all the way to the bottom.

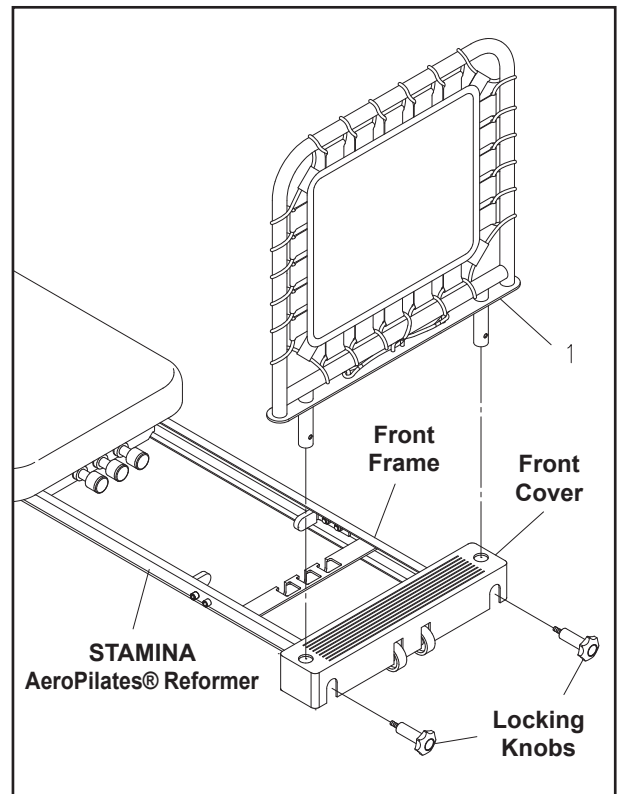

LIMITED WARRANTY

MODEL 55-0011B

WARRANTY

Stamina Products, Inc. ("Stamina") warrants to the original purchaser that this product will be free from defects in materials and workmanship that arise under normal use, service, proper assembly and proper operation in accordance with product warnings/instructions for a period of 90 days on the parts and three years on the frame from the date of the original purchase from an authorized retailer. **THIS WARRANTY SHALL NOT APPLY TO ANY PRODUCT WHICH HAS BEEN SUBJECT TO COMMERCIAL USE, ABUSE, MISUSE, ALTERATION OF ANY KIND OR TO ANY DEFECT OR CHANGE CAUSED BY IMPROPER ASSEMBLY, REPAIR, REPLACEMENT, SUBSTITUTION OR USE WITH PARTS NOT PROVIDED BY STAMINA.** Commercial use includes use of product in athletic clubs, health clubs, spas, gyms, and all other public or semipublic facilities whether or not the product's use is in furtherance of a profit making enterprise, and all other use which is not for personal purposes.

To implement this limited warranty, send a written notice stating your name, date, and place of purchase and a brief description of the defect along with your receipt to Stamina Products, Inc. 2040 N Alliance Ave, Springfield, Missouri, USA, MO 65803, or email us at customer.care@staminaproducts.com, or call us at 1-800-375-7520. If the defect is covered under this limited warranty, you will be requested to return the product or part to us for free repair or replacement at our option.

NO ACTION FOR BREACH OF THIS LIMITED WARRANTY MAY BE COMMENCED MORE THAN ONE (1) YEAR AFTER THE DATE THE ALLEGED BREACH WAS OR SHOULD HAVE BEEN DISCOVERED. NO ACTION FOR BREACH OF ANY IMPLIED WARRANTY (INCLUDING MERCHANTABILITY AND FITNESS FOR A PARTICULAR PURPOSE) MAY BE COMMENCED MORE THAN ONE (1) YEAR AFTER DELIVERY OF THE PRODUCT TO THE PURCHASER. These warranties are not transferable. **IF ANY PART OF THE PRODUCT IS NOT IN COMPLIANCE WITH THIS LIMITED WARRANTY OR ANY IMPLIED WARRANTY, THE REMEDY OF REPAIR OR REPLACEMENT IS THE EXCLUSIVE REMEDY.** If any claim is made under this limited warranty or any implied warranty, Stamina reserves the right to require the product to be returned for inspection, at the purchaser's expense, to Stamina's premises in Springfield, Missouri. Return of the enclosed warranty registration card is not required for warranty coverage, but is merely a way of establishing the date and place of purchase.

Stamina **SHALL NOT BE LIABLE FOR THE LOSS OF USE OF ANY PRODUCT, LOSS OF TIME, INCONVENIENCE, COMMERCIAL LOSS OR ANY OTHER INDIRECT, CONSEQUENTIAL, SPECIAL OR INCIDENTAL DAMAGES DUE TO BREACH OF THE ABOVE WARRANTY OR ANY IMPLIED WARRANTY.**

THIS LIMITED WARRANTY IS THE ONLY EXPRESS WARRANTY. NO ORAL OR WRITTEN INFORMATION GIVEN BY STAMINA, ITS AGENTS OR EMPLOYEES, SHALL CREATE A WARRANTY OR IN ANY WAY INCREASE THE SCOPE OF THIS WARRANTY. This warranty gives you specific legal rights, and you may also have other legal rights which vary from state to state. **ANY OTHER RIGHT WHICH YOU MAY HAVE, INCLUDING ANY IMPLIED WARRANTY OF MERCHANTABILITY OR FITNESS FOR A PARTICULAR PURPOSE, IS LIMITED IN DURATION TO THE DURATION OF THIS WARRANTY.**

The laws in some states affect the disclaimer or limitation of implied warranties and consequential and incidental damages. If any such law is found applicable, the foregoing disclaimers and limitations of and on implied warranties and consequential and incidental damages shall be deemed to be modified to the extent necessary to comply with applicable law.