

STAMINA[®]

MAGNETIC ROWER

Owner's Manual

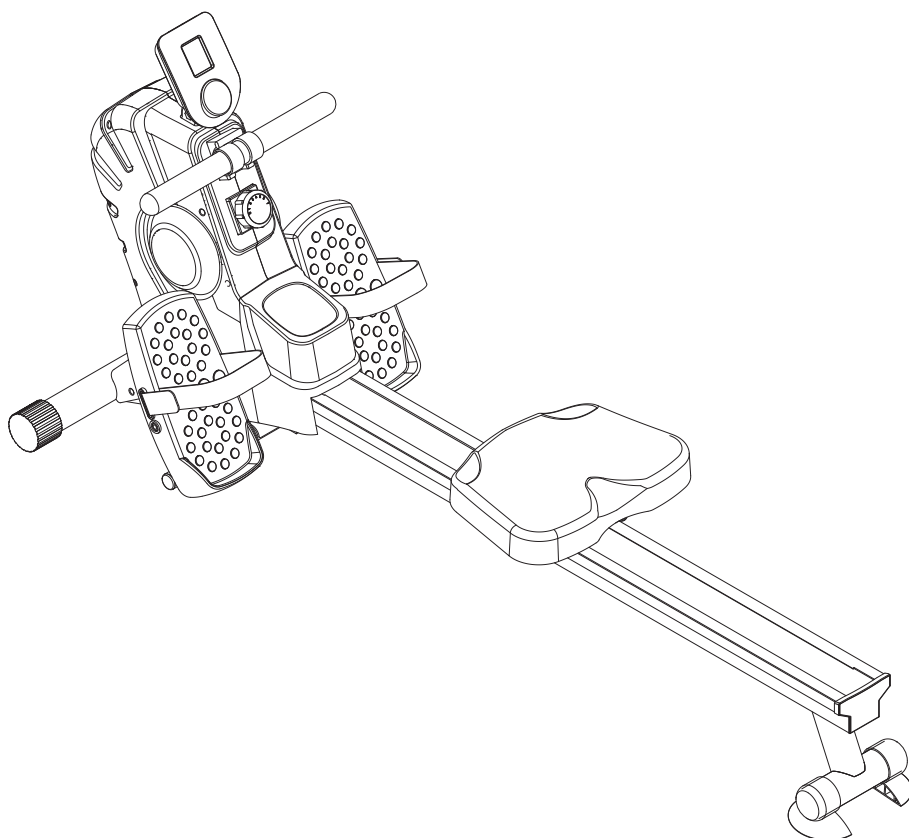

Product May Vary Slightly From Pictured.

CAUTION:

Weight on this product should not exceed 250 lbs.

▲ WARNING

Exercise can present a health risk. Consult a physician before beginning any exercise program with this equipment. If you feel faint or dizzy, immediately discontinue use of this equipment. Serious bodily injury can occur if this equipment is not assembled and used correctly. Serious bodily injury can also occur if all instructions are not followed. Keep others and pets away from equipment when in use. Always make sure all bolts and nuts are securely tightened prior to each use. Follow all safety instructions in this manual.

When calling for parts or service, please specify the following number:

Model#: 35-1101

This Product is Distributed Exclusively by



2040 N. Alliance, Springfield, MO 65803

Customer Care

1 (800) 375-7520

www.staminaproducts.com

**STAMINA PRODUCTS
MADE IN CHINA**

© 2017 Stamina Products, Inc.
2017, 07

TABLE OF CONTENTS

Safety Instructions	2	Conditioning Guidelines	14
Before You Begin	4	Warm-Up and Cool-Down	15
Equipment Warning, Caution & Notice Labels ...	5	Product Parts Drawing	16
Hardware Identification Chart	6	Parts List	17
Assembly Instructions	7	Warranty	19
Operational Instructions	11	Notes	20
Storage	13	Fax/Mail Ordering Form	22
Maintenance	13		

SAFETY INSTRUCTIONS

⚠ WARNING Cancer and Reproductive Harm www.P65Warnings.ca.gov

⚠ WARNING Consult your physician before starting this or any exercise program. This is especially important if you are over the age of 35, have never exercised before, are pregnant, or suffer from any health problem. This product is for home use only. Do not use in institutional or commercial applications. Failure to follow all warnings and instructions could result in serious injury or death.

⚠ WARNING To reduce the risk of serious injury, read the following Safety Instructions before using the Stamina® Magnetic Rower.

1. Save these instructions and ensure that other exercisers read this manual prior to using the **Stamina® Magnetic Rower** for the first time.
2. Read all warnings and cautions posted on the **Stamina® Magnetic Rower**.
3. The **Stamina® Magnetic Rower** should only be used after a thorough review of the Owner's Manual. Make sure that it is properly assembled and tightened before use.
4. We recommend that two people be available for assembly of this product.
5. Keep children away from the **Stamina® Magnetic Rower**. Do not allow children to use or play on the **Stamina® Magnetic Rower**. Keep children and pets away from the **Stamina® Magnetic Rower** when it is in use.
6. It is recommended that you place this exercise equipment on an equipment mat.
7. Set up and operate the **Stamina® Magnetic Rower** on a solid level surface. Do not position the **Stamina® Magnetic Rower** on loose rugs or uneven surfaces.
8. Make sure that adequate space is available for access to and around the **Stamina® Magnetic Rower**.
9. Before using, inspect the **Stamina® Magnetic Rower** for worn or loose components, and securely tighten or replace any worn or loose components prior to use.
10. Before using, check the condition of the STRAP(43). Replace the STRAP(43) if it is cracked or broken.
11. Consult a physician prior to commencing an exercise program and follow his/her recommendations in developing your fitness program. If at any time during exercise you feel faint, dizzy, or experience pain, stop and consult your physician.
12. Always choose the workout which best fits your physical strength and flexibility level. Know your limits and train within them. Always use common sense when exercising.
13. Do not wear loose or dangling clothing while using the **Stamina® Magnetic Rower**.
14. Never exercise in bare feet or socks; always wear proper footwear such as running, walking, or cross training shoes that fit well, provide foot support, and feature non-skid rubber soles.
15. Be careful to maintain your balance while using, mounting, dismounting, or assembling the **Stamina® Magnetic Rower**, loss of balance may result in a fall and bodily injury.
16. Do not use the SEAT(38) to move the **Stamina® Magnetic Rower**. The SEAT(38) will move and the SEAT CARRIAGE(94) may pinch your hand or fingers. When folding or unfolding the unit, keep all children away and make sure your hands are clear of any folding or pinch point.
17. The **Stamina® Magnetic Rower** should not be used by persons weighing over 250 pounds.
18. The **Stamina® Magnetic Rower** should be used by only one person at a time.
19. The **Stamina® Magnetic Rower** is for consumer use only. It is not for use in public or semipublic facilities.

EXTEND YOUR PARTS WARRANTY TO 180 DAYS FROM THE DATE OF PURCHASE. REGISTER YOUR PRODUCT.



**NEED HELP?
CONTACT US FIRST
1 (800) 375-7520
customer.care@staminaproducts.com**

Hi! From all of us here at Stamina Products, thank you for your purchase. We know that you have big fitness goals in mind and we are here to help you along. Call us, email us, or send us a message on Facebook. Be sure to contact us if you have any questions on your new product. We look forward to hearing from you!

With your body in mind,
Stamina Customer Care

To enact your extended warranty and to help us better serve you, please go online and register your new product.

register.staminaproducts.com

It is quick and easy to register online, but if you're a little old school or just need a reason to raise that little flag on your mailbox, fill out the info on the last page of this manual and mail it in.



ONLINE

customer.care@staminaproducts.com
www.staminaproducts.com



TELEPHONE

1 (800) 375-7520



FAX

(417) 889-8064



MAIL

Stamina Products, Inc.
ATTN: Customer Care
P.O. Box 1071
Springfield, MO 65801-1071

 facebook.com/StaminaProducts
facebook.com/AeroPilates

CUSTOMER CARE HOURS:
Monday-Thursday, 7:30 AM-5:00 PM, Central Time
Friday, 8:00 AM-3:00 PM, Central Time

BEFORE YOU BEGIN

Thank you for choosing the **Stamina® Magnetic Rower**. We take great pride in producing this quality product and hope it will provide many hours of quality exercise to make you feel better, look better, and enjoy life to its fullest.

It's a proven fact that a regular exercise program can improve your physical and mental health. Too often, our busy lifestyles limit our time and opportunity to exercise. The **Stamina® Magnetic Rower** provides a convenient and simple method to begin your journey of getting your body in shape and achieving a happier and healthier lifestyle.

Before reading further, please review the drawing below and familiarize yourself with the parts that are labeled.

Read this manual carefully before using the **Stamina® Magnetic Rower**.

Although Stamina constructs its products with the finest materials and uses the highest standards of manufacturing and quality control, there can sometimes be missing parts or incorrectly sized parts. If you have any questions or problems with the parts included with your **Stamina® Magnetic Rower**, please do not return the product. Contact us **FIRST!**

If a part is missing or defective, please go to staminaproducts.com under the Customer Care section and order the part needed, or call us toll free at 1-800-375-7520 (in the U.S.). Our Customer Care Staff is available to assist you from 7:30 A.M. to 5:00 P.M. (Central Time) Monday through Thursday and 8:00 A.M. to 3:00 P.M. (Central Time) on Friday.

Be sure to have the name and model number of the product available when you contact us.

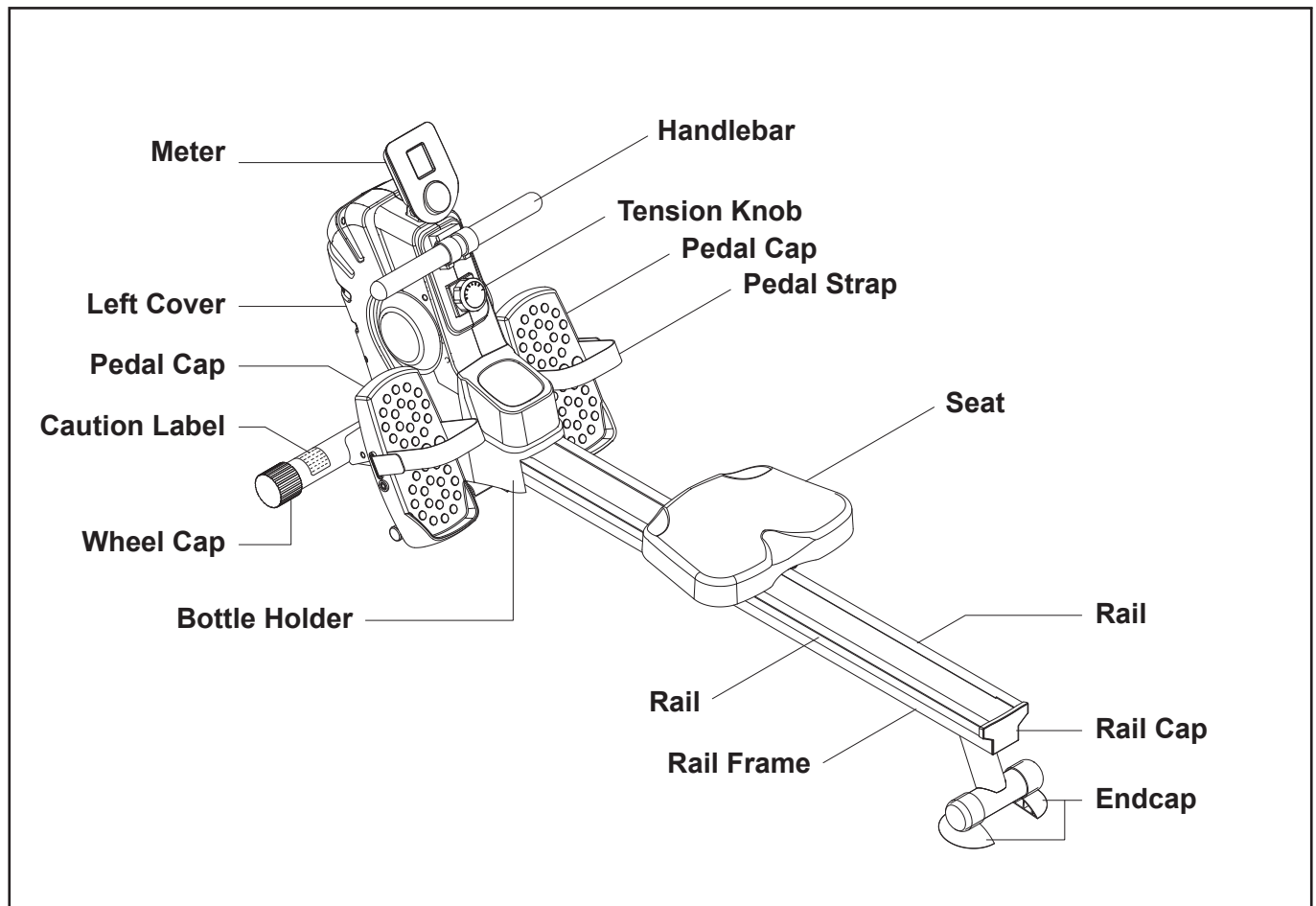

THE FOLLOWING TOOLS ARE INCLUDED FOR ASSEMBLY :



EQUIPMENT WARNING, CAUTION & NOTICE LABELS

This chart is provided to help identify the warning, caution, and notice labels on the **Stamina® Magnetic Rower**. Please take a moment to familiarize yourself with all of the warning, caution, and notice labels.

Label is larger than actual size

C1 CAUTION LABEL(31)



HARDWARE IDENTIFICATION CHART



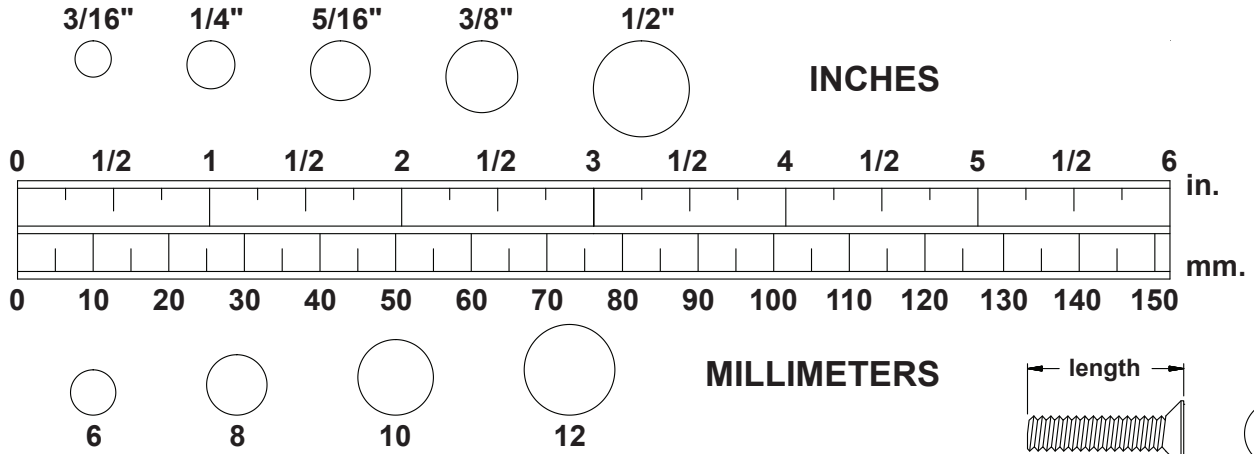

This chart is provided to help identify the fasteners used in the assembly process. Place the washers or the ends of the bolts or screws on the circles to check for the correct diameter. Use the small scale to check the length of the bolts and screws.

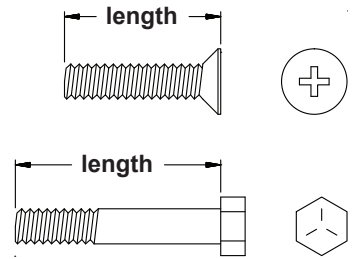

NOTICE: The length of all bolts and screws, except those with flat heads, is measured from below the head to the end of the bolt or screw. Flat head bolts and screws are measured from the top of the head to the end of the bolt or screw.

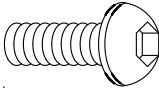
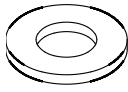
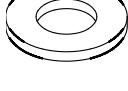

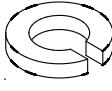
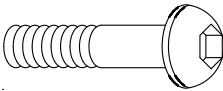
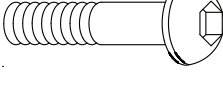
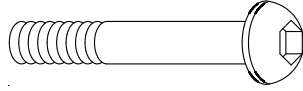
After unpacking the unit, open the hardware bag and make sure that you have all the following fasteners. Some fasteners may be already attached to the parts.

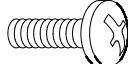
	Part Number and Description	Qty
	59 Bolt, Button Head (M8 x 1.25 x 15mm)	2
	60 Fender Washer (M8)	2
	62 Washer (M8)	2
	68 Washer (M6)	4
	63 Lock Washer (M8)	2
	64 Bolt, Button Head (M8 x 1.25 x 35mm)	2
	97 Bolt, Button Head (M8 x 1.25 x 45mm)	2
	65 Bolt, Button Head (M8 x 1.25 x 60mm)	2
	66 Arc Washer (M8)	4
	67 Bolt, Round Head (M6 x 1 x 15mm)	4

ASSEMBLY INSTRUCTIONS

Place all parts from the box in a cleared area and position them on the floor in front of you. Remove all packing materials from your area and place them back into the box. Do not dispose of the packing materials until assembly is completed. Read each step carefully before beginning. If you are missing a part, please go to staminaproducts.com under the Customer Care section and order the part needed, e-mail us at customer.care@staminaproducts.com, or call us toll free at 1-800-375-7520 (in the U.S.). Our Customer Care Staff is available to assist you from 7:30 A.M. to 5:00 P.M. (Central Time) Monday through Thursday and 8:00 A.M. to 3:00 P.M. (Central Time) on Friday.

STEP 1

Position the main assembly of the **Stamina® Magnetic Rower** as shown in the illustration below. Attach the **FRONT STABILIZER(3)** to the **MAIN FRAME(1)** with **BUTTON HEAD BOLTS(M8x1.25x60mm)(65)** and **ARC WASHERS(M8)(66)**.

STEP 2

Attach the **PEDAL STOPPER BAR(4)** to the **MAIN FRAME(1)** with **BUTTON HEAD BOLTS(M8x1.25x35mm)(64)** and **ARC WASHERS(M8)(66)**.

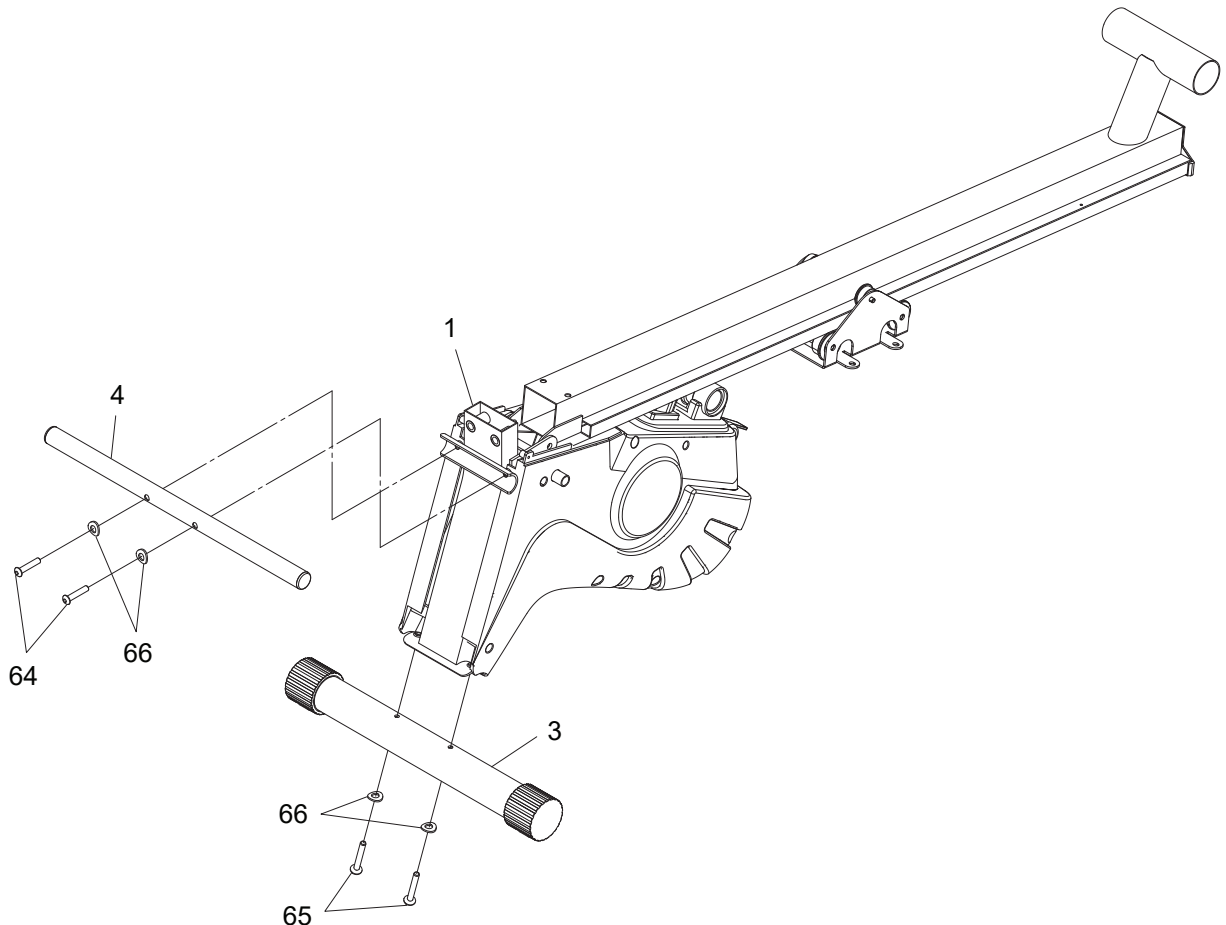

ASSEMBLY INSTRUCTIONS

STEP 3

Refer to the illustration below. Unfold the **RAIL FRAME(2)**, and then attach to the **MAIN FRAME(1)** with **BUTTON HEAD BOLTS(M8x1.25x45mm)(97)**, **LOCK WASHERS(M8)(63)**, and **WASHERS(M8)(62)**.

STEP 4

Attach the **SEAT(38)** to the **SEAT CARRIAGE(94)** with **ROUND HEAD BOLTS(M6x1x15mm)(67)** and **WASHERS(M6)(68)**.

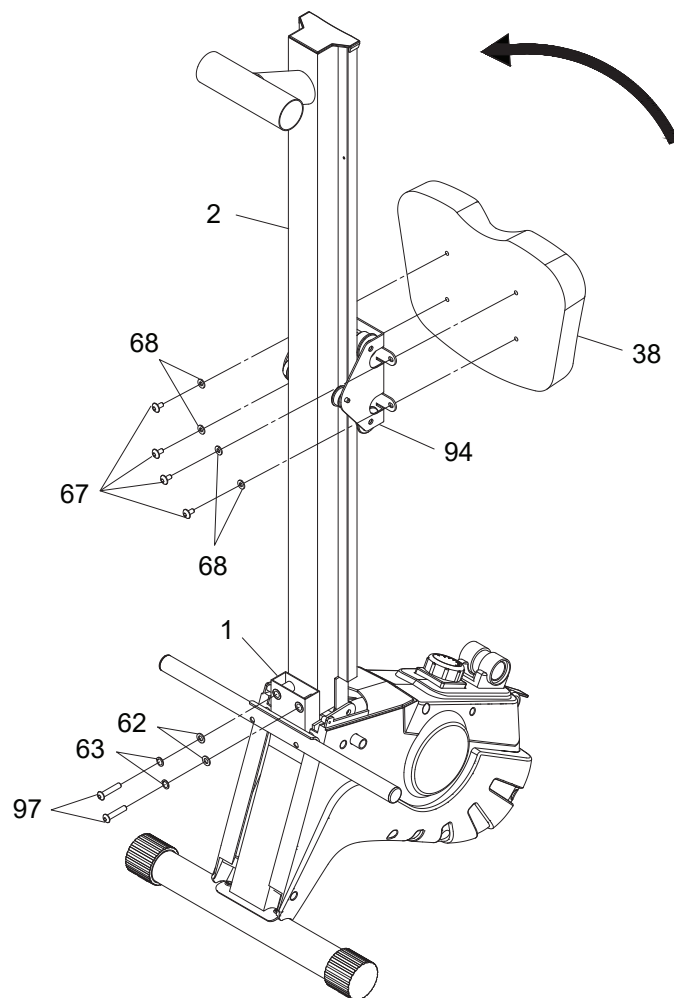

ASSEMBLY INSTRUCTIONS

STEP 5

Insert the **HANDLEBAR(5)** through the **HANDLEBAR SLEEVE(41)**. Slide the **FOAM GRIP(39)** onto the protruding end of the **HANDLEBAR(5)**.

NOTE: Lubricate the **HANDLEBAR(5)** with a small amount of liquid soap or water for easier installation of the **FOAM GRIP(39)**.

STEP 6

To help install the **BOTTLE HOLDER(35)**, loosen the **ROUND HEAD SCREW(ST4.2x16mm)(72)** on the **RIGHT COVER(34)**. Push the **BOTTLE HOLDER(35)** into the gap of the **LEFT** and **RIGHT COVERS (33, 34)**. Tighten the **ROUND HEAD SCREW(ST4.2x16mm)(72)** on the **RIGHT COVER(34)**.

STEP 7

Press the **ENDCAPS(45)** onto both sides of the **RAIL FRAME(2)**.

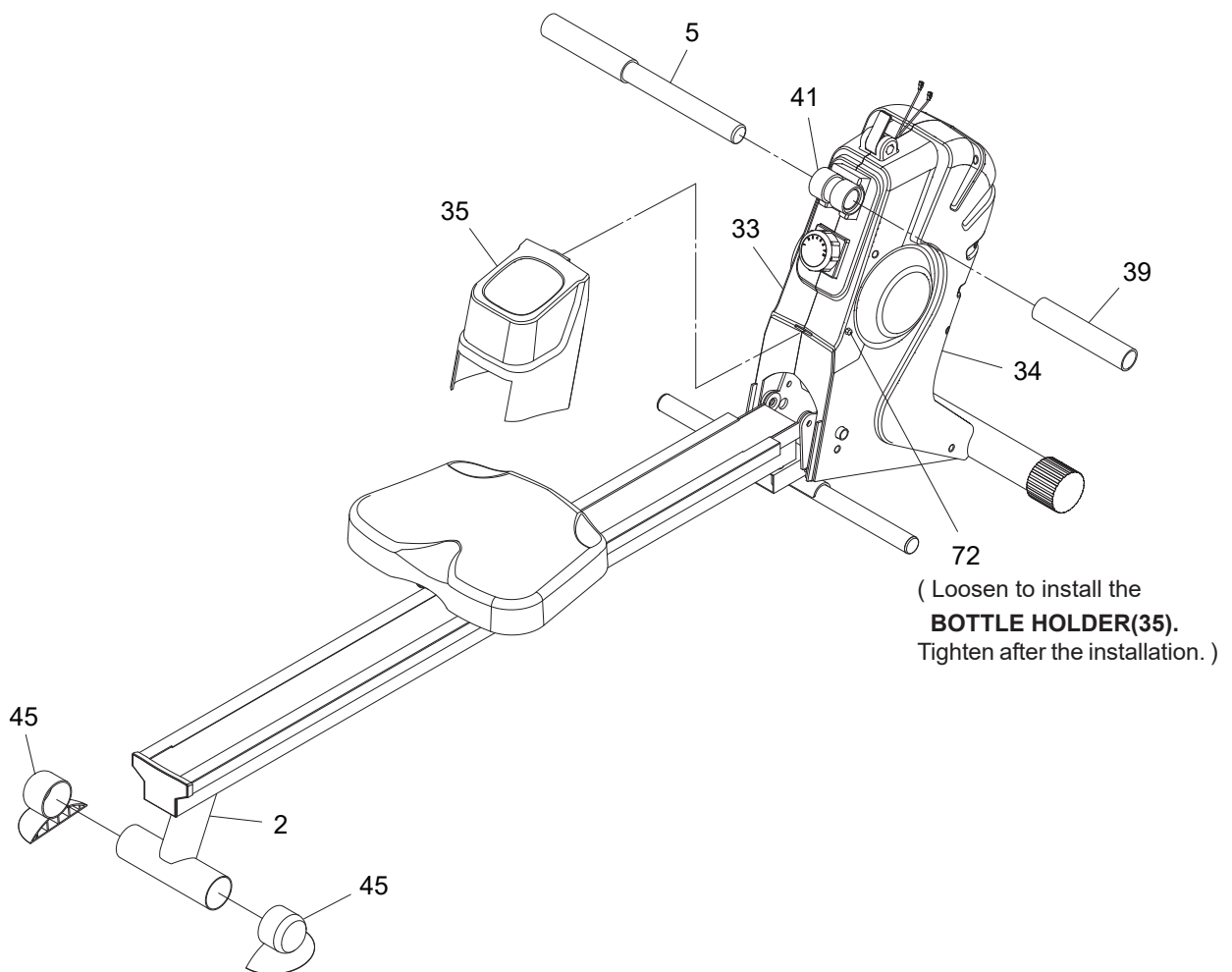

ASSEMBLY INSTRUCTIONS

STEP 8

There is an “L” decal on the left **PEDAL CAP(36L)**, and an “R” decal on the right **PEDAL CAP(36R)**. Insert the **PEDAL SHAFT(10)** through the tube located on the **MAIN FRAME(1)**. Slide the left **PEDAL CAP(36L)** onto the left side of the **PEDAL SHAFT(10)**. Slide the right **PEDAL CAP(36R)** onto the right side of the **PEDAL SHAFT(10)**. Then secure the **PEDAL CAPS(36)** with **BUTTON HEAD BOLTS(M8x1.25x15mm)(59)** and **FENDER WASHERS(M8)(60)** at both ends of the **PEDAL SHAFT(10)**. You need to use two Allen Wrenches to tighten the **BUTTON HEAD BOLTS(M8x1.25x15mm)(59)** at both ends of the **PEDAL SHAFT(10)** at the same time.

STEP 9

Install two AAA batteries into the **METER(13)**, the batteries are not included. See page 12 for detailed battery installation instructions. Insert the **METER(13)** onto the **METER PLATE(48)**. Connect the **SENSOR WIRES(15)** to the connecting wires of the **METER(13)**.

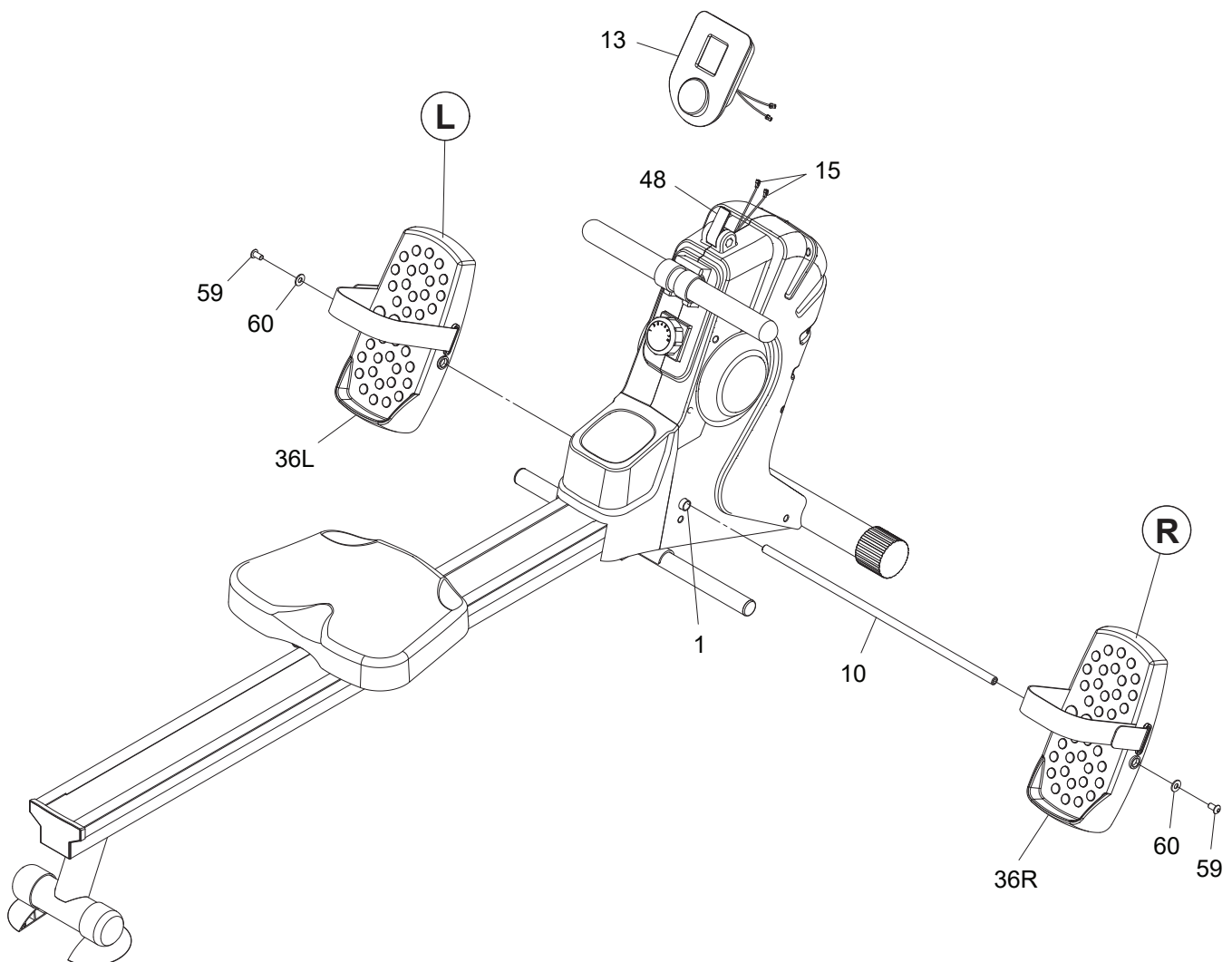

OPERATIONAL INSTRUCTIONS

USING THE FITNESS METER

POWER ON: Handlebar movement or press any button.

POWER OFF: Automatically shuts off after 4 minutes of inactivity.

FUNCTION BUTTONS :

MODE : In the setting mode, press and release to select each function for preset target values for STROKES, TIME, DISTANCE, and CALORIES.

Press and release to select functions for display for DISTANCE, CALORIES, ST./TIME, and TOTAL.

SET : In the setting mode, press to set target values. Press the button and hold it down for two seconds, the meter will continue to add the values even without pressing the **SET** button. Press any button to stop.

RESET : In the setting mode, press the button to reset the setting values to zero.

Press the button and hold it down for two seconds to reset all functions to zero.

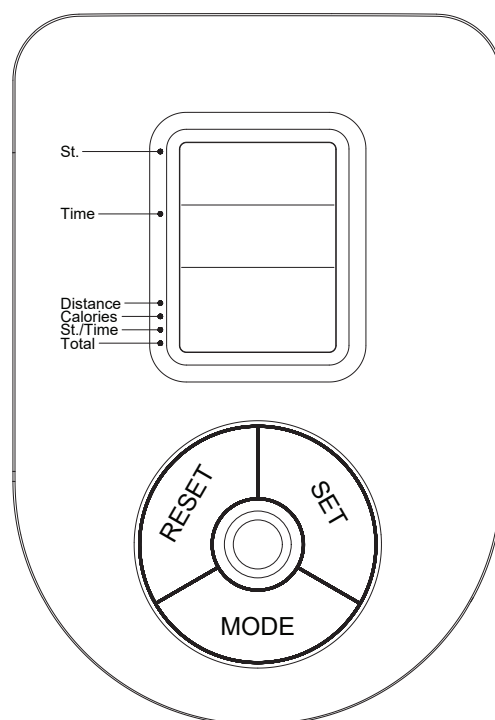

FUNCTIONS:

STROKES: Displays the total number of strokes you have taken from zero to 9999 strokes. Counts down from preset value.

TIME: Displays the time from 1 sec. up to 99:59 minutes. Counts down from preset value.

DISTANCE: Displays distance from zero to 99.99 Miles. Counts down from preset value.

CALORIES: Displays the calories burned from zero to 999 Kcal. Counts down from preset value.

The calorie readout is an estimate for an average user. It should be used only as a comparison between workouts on this unit.

STROKES/TIME: Displays the rowing speed from zero to 999 strokes per minute.

TOTAL: Displays the total accumulated number of strokes you have taken from zero to 9999 strokes. The total accumulated strokes is retained when the meter is turned off, until the batteries are removed.

PRESET VALUES OPERATION:

You can pull on the **HANDLEBAR(5)** to power on the meter and workout with the meter directly. Or, you can preset the function values for counting down. Stop rowing for four seconds, the meter will enter setting mode. The meter will go through the input items as follows and allow you to set the function values. Use **SET** and **RESET** buttons to input the values, and press **MODE** button to confirm. Or, just press the **MODE** button to skip the setting and move on to the next function. After all the desired settings are chosen, begin pulling on the **HANDLEBAR(5)** to start the workout.

Strokes (10 to 9990) → Time (1:00 to 99:00) → Distance (0.1 to 99.9 mile) → Calories (1.0 to 999 Kcal)

NOTE:

1. You may preset values for several functions. The preset function values will start to count down. When you complete one of the preset functions, the meter will remind you with an audible alarm for three seconds. Then the value of this completed function will start to count up, while the other preset functions will continue to count down.
2. The Meter will shut off automatically after 4 minutes of inactivity. All function values will be kept. Press the **RESET** button and hold it down for two seconds to reset all functions to zero.

OPERATIONAL INSTRUCTIONS

HOW TO INSTALL AND REPLACE BATTERIES:

1. Open the Battery Door on the back of the meter.
2. The meter operates with two AAA batteries, the batteries are not included. Refer to the illustration to install or replace the batteries.

- NOTE:**
1. Do not mix a new battery with an old battery.
 2. Use the same type of battery. Do not mix an alkaline battery with another type of battery.
 3. Rechargeable batteries are not recommended.
 4. **Ultimate disposal of battery should be handled according to all state and federal laws and regulations.**
 5. **Do not dispose of batteries in fire.**

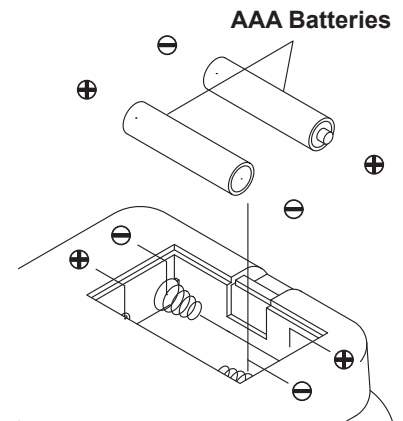

LOAD ADJUSTMENT

To increase the load, turn the **TENSION KNOB(47)** clockwise. To decrease the load, turn the **TENSION KNOB(47)** counterclockwise. There are eight levels for the load adjustment.

NOTE: The load will increase as you pull faster.

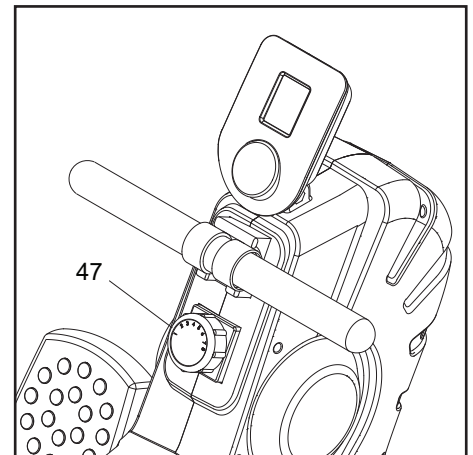

STORAGE

1. To store the **Stamina® Magnetic Rower**, simply keep it in a clean dry place.
2. Move the **Stamina® Magnetic Rower** with the moving wheels on the **FRONT STABILIZER(3)**. Lift the Rear Stabilizer on the **RAIL FRAME(2)** to move the **Stamina® Magnetic Rower**. Do not use the **SEAT(38)** to move the **Stamina® Magnetic Rower**. The **SEAT(38)** will move and the **SEAT CARRIAGE(94)** may pinch your hand or fingers.
3. To avoid damage to the meter, remove the batteries before storing the **Stamina® Magnetic Rower** for one year or more.
4. Refer to the illustration below. You can stand the **Stamina® Magnetic Rower** on end for storage.

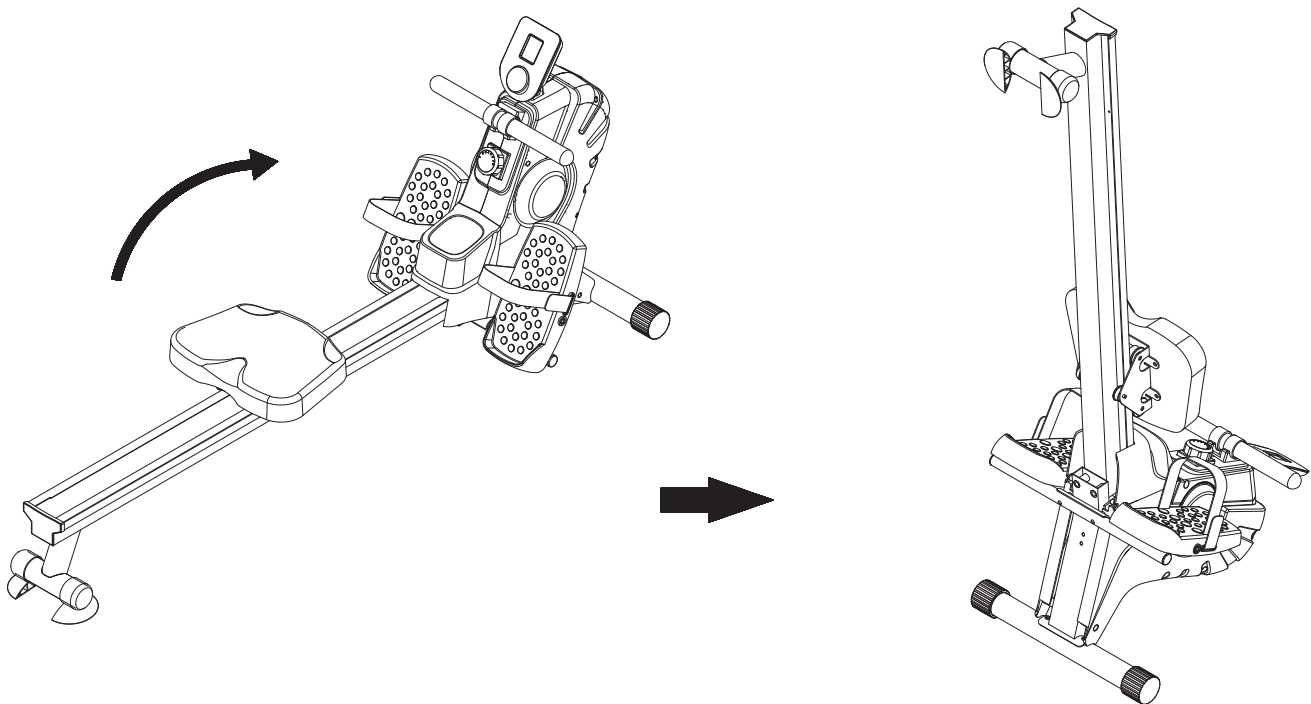

MAINTENANCE

The safety and integrity designed into the **Stamina® Magnetic Rower** can only be maintained when the **Stamina® Magnetic Rower** is regularly examined for damage and wear. Special attention should be given to the following:

1. Pull on the **HANDLEBAR(5)** and verify that the Magnetic System provides tension and the seat travel is smooth and stable.
2. Clean the roller tracks in the **RAILS(30)** with an absorbent cloth.
3. Verify that all nuts and bolts are present and properly tightened. Replace missing nuts and bolts. Tighten loose nuts and bolts.
4. Check the condition of the **STRAP(43)**. Replace the **STRAP(43)** if it is cracked or broken.
5. Verify that the **CAUTION LABEL(31)** is in place and easy to read. Call Stamina Products immediately at **1-800-375-7520** for a replacement **CAUTION LABEL(31)** if it is missing or damaged.
6. It is the sole responsibility of the user/owner to ensure that regular maintenance is performed.
7. Worn or damaged components must be replaced immediately or the **Stamina® Magnetic Rower** removed from service until repair is made.
8. Only Stamina Products supplied components should be used to maintain/repair the **Stamina® Magnetic Rower**.
9. Keep your **Stamina® Magnetic Rower** clean by wiping it off with an absorbent cloth after use.

CONDITIONING GUIDELINES

How you begin your exercise program depends on your physical condition. If you have been inactive for several years or are severely overweight, start slowly and increase your workout time gradually. Increase your workout intensity gradually by monitoring your heart rate while you exercise.

Remember to follow these essentials:

- Have your doctor review your training and diet programs.
- Begin your training program slowly with realistic goals that have been set by you and your physician.
- Warm up before you exercise and cool down after you work out.
- Take your pulse periodically during your workout and strive to stay within a range of 60% (lower intensity) to 90% (higher intensity) of your maximum heart rate zone. Start at the lower intensity, and build up to higher intensity as you become more aerobically fit.
- If you feel dizzy or lightheaded you should slow down or stop exercising.

Initially you may only be able to exercise within your target zone for a few minutes; however, your aerobic capacity will improve over the next six to eight weeks. It is important to pace yourself while you exercise so you don't tire too quickly.

To determine if you are working out at the correct intensity, use a heart rate monitor or use the table below. For effective aerobic exercise, your heart rate should be maintained at a level between 60% and 90% of your maximum heart rate. If just starting an exercise program, work out at the low end of your target heart rate zone. As your aerobic capacity improves, gradually increase the intensity of your workout by increasing your heart rate.

Measure your heart rate periodically during your workout by stopping the exercise but continuing to move your legs or walk around. Place two or three fingers on your wrist and take a six second heartbeat count. Multiply the results by ten to find your heart rate. For example, if your six second heartbeat count is 14, your heart rate is 140 beats per minute. A six second count is used because your heart rate will drop rapidly when you stop exercising. Adjust the intensity of your exercise until your heart rate is at the proper level.

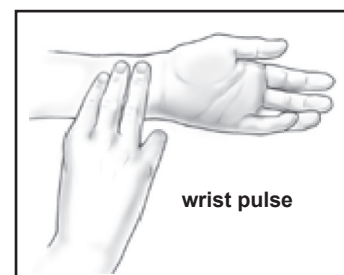

Target Heart Rate Zone Estimated by Age*

Age	Target Heart Rate Zone (55%-90% of Maximum Heart Rate)	Average Maximum Heart Rate 100%
20 years	110-180 beats per minute	200 beats per minute
25 years	107-175 beats per minute	195 beats per minute
30 years	105-171 beats per minute	190 beats per minute
35 years	102-166 beats per minute	185 beats per minute
40 years	99-162 beats per minute	180 beats per minute
45 years	97-157 beats per minute	175 beats per minute
50 years	94-153 beats per minute	170 beats per minute
55 years	91-148 beats per minute	165 beats per minute
60 years	88-144 beats per minute	160 beats per minute
65 years	85-139 beats per minute	155 beats per minute
70 years	83-135 beats per minute	150 beats per minute

* For cardiorespiratory training benefits, the American College of Sports Medicine recommends working out within a heart rate range of 55% to 90% of maximum heart rate. To predict the maximum heart rate, the following formula was used: $220 - \text{Age} = \text{predicted maximum heart rate}$

WARM-UP and COOL-DOWN

Warm-Up The purpose of warming up is to prepare your body for exercise and to minimize injuries. Warm up for two to five minutes before strength training or aerobic exercising. Perform activities that raise your heart rate and warm the working muscles. Activities may include brisk walking, jogging, jumping jacks, jump rope, and running in place.

Stretching Stretching while your muscles are warm after a proper warm-up and again after your strength or aerobic training session is very important. Muscles stretch more easily at these times because of their elevated temperature, which greatly reduces the risk of injury. Stretches should be held for 15 to 30 seconds. Do not bounce.

Suggested Stretching Exercises

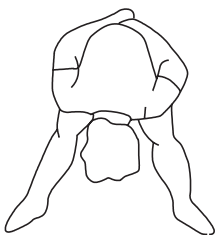

Lower Body Stretch

Place feet shoulder-width apart and lean forward. Keep this position for 30 seconds using the body as a natural weight to stretch the backs of the legs. **DO NOT BOUNCE!** When the pull on the back of the legs lessens, gradually try a lower position.

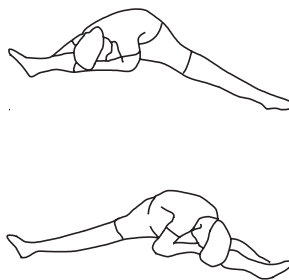

Floor Stretch

While sitting on the floor, open the legs as wide as possible. Stretch the upper body toward the knee on the right leg by using your arms to pull your chest to your thighs. Hold this stretch 10 to 30 seconds. **DO NOT BOUNCE!** Do this stretch 10 times. Repeat the stretch with the left leg.

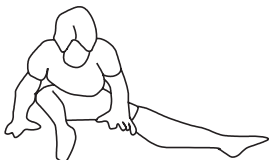

Bent Torso Pulls

While sitting on the floor, have legs apart, one leg straight and one knee bent. Pull the chest down to touch the thigh on the leg that is bent, and twist at the waist. Hold this position at least 10 seconds. Repeat 10 times on each side.

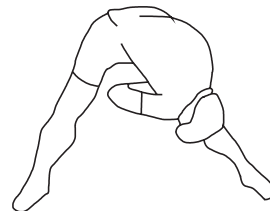

Bent Over Leg Stretch

Stand with feet shoulder-width apart and lean forward as illustrated. Using the arms, **gently** pull the upper body towards the right leg. Let the head hang down. **DO NOT BOUNCE!** Hold the position a minimum of 10 seconds. Repeat pulling the upper body to the left leg. Do this stretch several times slowly.

Remember to always check with your physician before starting any exercise program.

Cool-Down The purpose of cooling down is to return the body to its normal, or near normal, resting state at the end of each exercise session. A proper cool-down slowly lowers your heart rate and allows blood to return to the heart. Your cool-down should include the stretches listed above and should be completed after each strength training session.

PRODUCT PARTS DRAWING

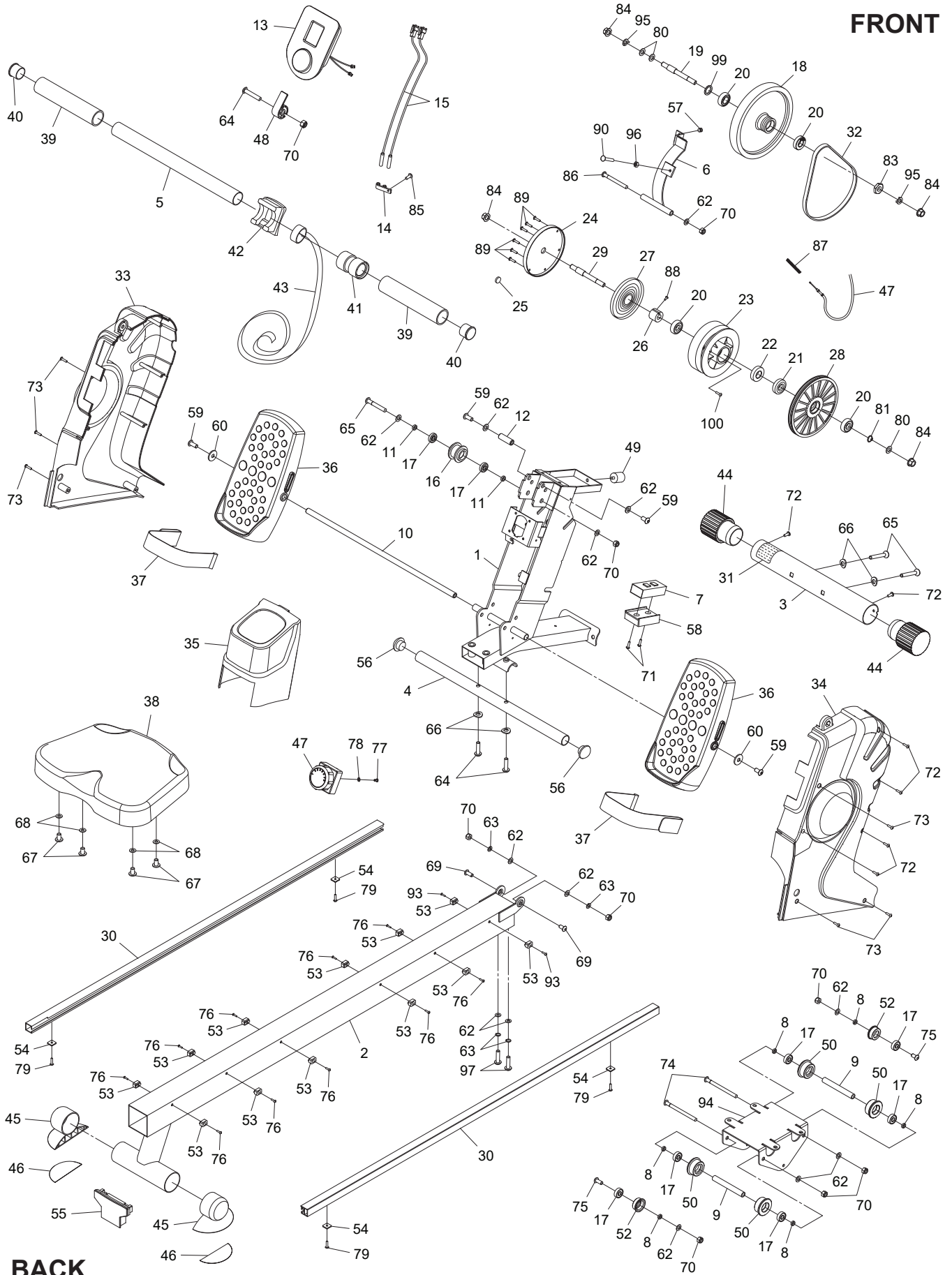

FRONT

BACK

PARTS LIST

PART#	PART NAME	QTY
1	Main Frame	1
2	Rail Frame	1
3	Front Stabilizer	1
4	Pedal Stopper Bar	1
5	Handlebar	1
6	Magnetic Brake	1
7	Secondary Magnetic Brake	1
8	Spacer (ø8.2 x ø12 x 3.2mm)	6
9	Long Spacer (ø8.2 x ø12 x 93.5mm)	2
10	Pedal Shaft	1
11	Spacer (ø8 x ø10 x 7mm)	2
12	Spacer (ø8 x ø12.8 x 38.5mm)	1
13	Meter	1
14	Sensor Clip	1
15	Sensor Wire	2
16	Idler Wheel	1
17	Bearing (608zz)	8
18	Magnetic Flywheel	1
19	Flywheel Shaft	1
20	Bearing (6000RS)	4
21	Bearing (6003RS)	1
22	One-way Bearing (HF1712)	1
23	Strap Pulley	1
24	Strap Pulley Cover	1
25	Magnet	1
26	Spiral Spring Core	1
27	Flat Spiral Spring	1
28	Pulley	1
29	Strap Pulley Shaft	1
30	Rail	2
31	Caution Label	1
32	V-Ribbed Belt	1
33	Left Cover	1
34	Right Cover	1
35	Bottle Holder	1
36	Pedal Cap	2
37	Pedal Strap	2
38	Seat	1
39	Foam Grip	2
40	Round Plug (ø32mm)	2
41	Handlebar Sleeve	1
42	Handlebar Holder	1
43	Strap	1
44	Wheel Cap	2
45	Endcap (60mm)	2
46	Non-skid Pad	2
47	Tension Knob	1
48	Meter Plate	1
49	Foot Stand	1
50	Roller	4

PARTS LIST

PART#	PART NAME	QTY
52	Guide Roller	2
53	Rail Retainer	12
54	Seat Stopper	4
55	Rail Cap	1
56	Round Plug (ø25mm)	2
57	Retaining Plug	1
58	Support Bumper	1
59	Bolt, Button Head (M8 x 1.25 x 15mm)	4
60	Fender Washer (M8)	2
62	Washer (M8)	13
63	Lock Washer (M8)	4
64	Bolt, Button Head (M8 x 1.25 x 35mm)	3
65	Bolt, Button Head (M8 x 1.25 x 60mm)	3
66	Arc Washer (M8)	4
67	Bolt, Round Head (M6 x 1 x 15mm)	4
68	Washer (M6)	4
69	Bolt, Button Head (M8 x 1.25 x 20mm)	2
70	Nylock Nut (M8 x 1.25)	9
71	Bolt, Button Head (M6 x 1 x 50mm)	2
72	Screw, Round Head (ST4.2 x 16mm)	6
73	Screw, Round Head Self-Drill (ST4.2 x 20mm)	6
74	Bolt, Button Head (M8 x 1.25 x 130mm)	2
75	Bolt, Button Head (M8 x 1.25 x 25mm)	2
76	Bolt, Socket Head (M5 x 0.8 x 10mm)	10
77	Screw, Round Head (M5 x 0.8 x 16mm)	1
78	Washer (M6)	1
79	Screw, Round Head (M4 x 0.7 x 10mm)	4
80	Washer (M10)	3
81	C Ring (S10)	1
83	Thin Nut (M10 x 1.25, 6mm thick)	1
84	Flange Nut (M10 x 1.25)	4
85	Screw, Round Washer Head (M4 x 0.7 x 10mm)	1
86	Bolt, Button Head (M8 x 1.25 x 90mm)	1
87	Spring	1
88	Screw, Round Washer Head (ST3 x 6mm)	1
89	Screw, Flat Head (ST4.2 x 16mm)	6
90	Bolt, Round Head (M6 x 1 x 20mm)	1
91	Allen Wrench (5mm)	1
92	Allen Wrench (5mm) w/ Screwdriver	1
93	Screw, Round Head (M5 x 0.8 x 25mm)	2
94	Seat Carriage	1
95	Locking Washer	2
96	Nut (M6 x 1)	1
97	Bolt, Button Head (M8 x 1.25 x 45mm)	2
98	Manual	1
99	Plastic Spacer (ø10.2 x ø14 x 2mm)	1
100	Screw, Round Head Self-Tapping (ST4.2 x 22mm)	1

LIMITED WARRANTY

MODEL 35-1101

WARRANTY

Stamina Products, Inc. ("Stamina") warrants to the original purchaser that this product will be free from defects in materials and workmanship that arise under normal use, service, proper assembly and proper operation in accordance with product warnings/instructions for a period of 90 days on the parts and three years on the frame from the date of the original purchase from an authorized retailer. **THIS WARRANTY SHALL NOT APPLY TO ANY PRODUCT WHICH HAS BEEN SUBJECT TO COMMERCIAL USE, ABUSE, MISUSE, ALTERATION OF ANY KIND OR TO ANY DEFECT OR CHANGE CAUSED BY IMPROPER ASSEMBLY, REPAIR, REPLACEMENT, SUBSTITUTION OR USE WITH PARTS NOT PROVIDED BY STAMINA.** Commercial use includes use of product in athletic clubs, health clubs, spas, gyms, and all other public or semipublic facilities whether or not the product's use is in furtherance of a profit making enterprise, and all other use which is not for personal purposes.

To implement this limited warranty, send a written notice stating your name, date, and place of purchase and a brief description of the defect along with your receipt to Stamina Products, Inc. P.O. Box 1071, Springfield Missouri, USA, 65801-1071, or email us at customer.care@staminaproducts.com, or call us at 1-800-375-7520. If the defect is covered under this limited warranty, you will be requested to return the product or part to us for free repair or replacement at our option.

NO ACTION FOR BREACH OF THIS LIMITED WARRANTY MAY BE COMMENCED MORE THAN ONE (1) YEAR AFTER THE DATE THE ALLEGED BREACH WAS OR SHOULD HAVE BEEN DISCOVERED. NO ACTION FOR BREACH OF ANY IMPLIED WARRANTY (INCLUDING MERCHANTABILITY AND FITNESS FOR A PARTICULAR PURPOSE) MAY BE COMMENCED MORE THAN ONE (1) YEAR AFTER DELIVERY OF THE PRODUCT TO THE PURCHASER. These warranties are not transferable. IF ANY PART OF THE PRODUCT IS NOT IN COMPLIANCE WITH THIS LIMITED WARRANTY OR ANY IMPLIED WARRANTY, THE REMEDY OF REPAIR OR REPLACEMENT IS THE EXCLUSIVE REMEDY. If any claim is made under this limited warranty or any implied warranty, Stamina reserves the right to require the product to be returned for inspection, at the purchaser's expense, to Stamina's premises in Springfield, Missouri. Return of the enclosed warranty registration card is not required for warranty coverage, but is merely a way of establishing the date and place of purchase.

Stamina **SHALL NOT BE LIABLE FOR THE LOSS OF USE OF ANY PRODUCT, LOSS OF TIME, INCONVENIENCE, COMMERCIAL LOSS OR ANY OTHER INDIRECT, CONSEQUENTIAL, SPECIAL OR INCIDENTAL DAMAGES DUE TO BREACH OF THE ABOVE WARRANTY OR ANY IMPLIED WARRANTY.**

THIS LIMITED WARRANTY IS THE ONLY EXPRESS WARRANTY. NO ORAL OR WRITTEN INFORMATION GIVEN BY STAMINA, ITS AGENTS OR EMPLOYEES, SHALL CREATE A WARRANTY OR IN ANY WAY INCREASE THE SCOPE OF THIS WARRANTY. This warranty gives you specific legal rights, and you may also have other legal rights which vary from state to state. **ANY OTHER RIGHT WHICH YOU MAY HAVE, INCLUDING ANY IMPLIED WARRANTY OF MERCHANTABILITY OR FITNESS FOR A PARTICULAR PURPOSE, IS LIMITED IN DURATION TO THE DURATION OF THIS WARRANTY.**

The laws in some states affect the disclaimer or limitation of implied warranties and consequential and incidental damages. If any such law is found applicable, the foregoing disclaimers and limitations of and on implied warranties and consequential and incidental damages shall be deemed to be modified to the extent necessary to comply with applicable law.

NOTES

NOTES

TO CONTACT CUSTOMER CARE

For your convenience, Stamina's customer care representatives can be reached by email at customer.care@staminaproducts.com or by phone at 1-800-375-7520 (in the U.S.). Our customer care representatives are available Monday through Thursday from 7:30 a.m. until 5:00 p.m., and Friday 8:00 a.m. until 3 p.m. Central Time.



**ONLINE
CUSTOMER CARE**
customer.care@staminaproducts.com
www.staminaproducts.com



**TELEPHONE
CUSTOMER CARE**
Tel: 1 (800) 375-7520



**FAX
CUSTOMER CARE**
Fax: (417) 889-8064



MAIL
STAMINA PRODUCTS, INC.
ATTN: Customer Care
P.O. Box 1071 Springfield, MO. 65801-1071

Would you like to receive email information or special offers from Stamina Products? Register at contact.staminaproducts.com

TO REGISTER YOUR PRODUCT

To enact your warranty, please register your product by going to register.staminaproducts.com. Please have your product model number (printed on the cover of this owner's manual) and the serial number (printed on the black and white sticker on your product) ready.

If you don't have internet access, you can call customer care at 1-800-375-7520, or fill out and mail the product registration form below to Stamina Products, Inc.; P.O. Box 1071; Springfield, MO 65801-1071.

PRODUCT REGISTRATION FORM	Stamina Products, Inc. P.O. Box 1071 Springfield, MO 65801-1071
Model Number:	Serial Number:
Product Name:	
Place Purchased:	
Date of Purchase:	Purchase Price:
First Name:	Last Name:
City:	State: Zip Code:
Email Address:	Phone #: ()
Would you like to receive email information or special offers from Stamina Products?* <input type="checkbox"/> Yes <input type="checkbox"/> No *If yes, be sure your email address is included above.	



Detach and Mail or Fax the Form Above



TO ORDER PARTS

If there are missing or damaged parts, you can go to parts.staminaproducts.com and order those parts. If you have questions, please contact customer care. Do not return the product. To order parts by mail, fill out the sheet below and fax it to 417-889-8064. The part will be mailed to your address.



Detach and Mail or Fax the Form Below



PARTS ORDER FORM	Stamina Products, Inc. P.O. Box 1071 Springfield, MO 65801-1071	
Mr./Ms:		
Address:		
Apt. #:		
City:	State: Zip Code:	
IMPORTANT : We require your phone number to process the order!		
Phone #: ()	Work Phone #: ()	
Date of Purchase:		
Model #:		
Purchased From:		
IMPORTANT: Before filling out the portion below, make sure you have the correct information. Refer to the parts list to make sure you're ordering the right parts!		
PART #	DESCRIPTION	QUANTITY
EXAMPLE: 1	Rear Unit Assembly	1