

AeroPilates®

LESS STRESS | MORE HEART

PRECISION SERIES CADILLAC

Owner's Manual

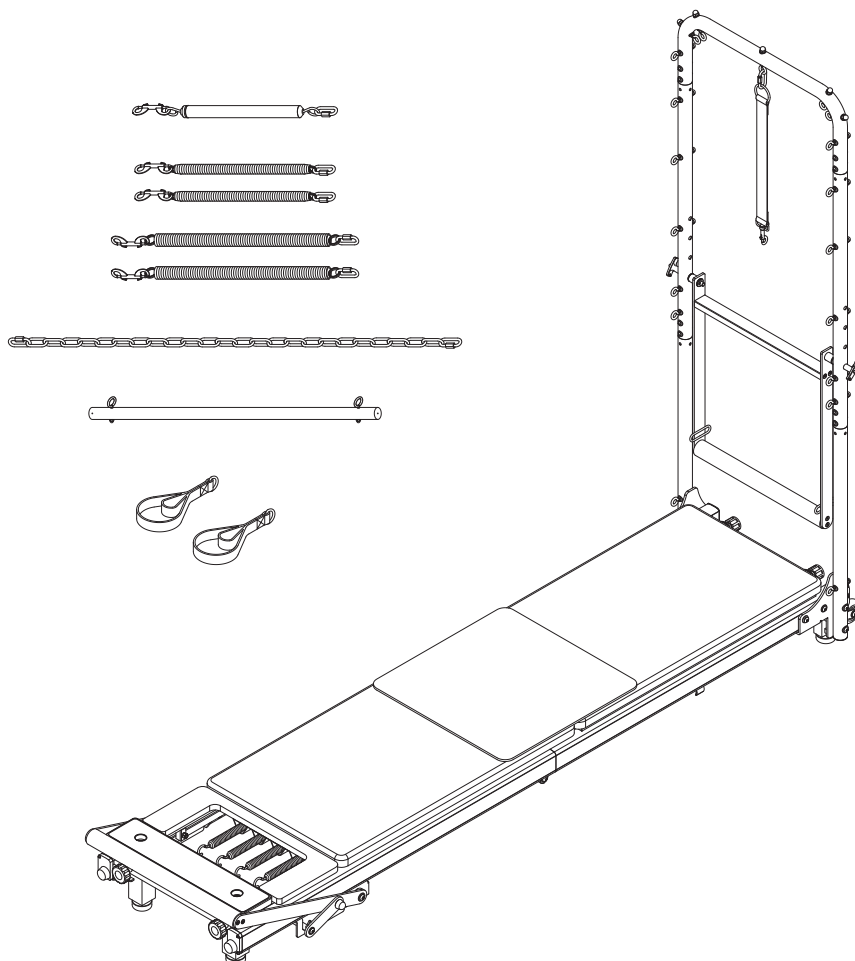

Product May Vary Slightly From Pictured.

CAUTION:

Weight on this product should not exceed 350 lbs.

⚠ WARNING

- Exercise can present a health risk. Consult a physician before beginning any exercise program with this equipment. If you feel faint or dizzy, immediately discontinue use.
- Serious bodily injury can occur if this equipment is not assembled and used in accordance with the owner's manual.
- Follow all safety instructions in this owner's manual.

When calling for parts or service, please specify the following numbers:

Model#: 55-5605

S/N: _____

This Product is Distributed Exclusively by



4435 West Manufacturers Street, Springfield, MO 65803

Customer Care

1 (800) 375-7520

www.staminaproducts.com

United States and/or International patents apply and/or are pending. See www.staminaproducts.com for details.

**STAMINA PRODUCTS
MADE IN CHINA**

© 2025 Stamina Products, Inc.
2025, 10



ACCESS YOUR ONLINE WORKOUT VIDEOS!

How to Access Your Videos

1. Go to video.staminaproducts.com
2. Click 
3. Enter your product VIDEO CODE

*Your **video code** is the model number.*

Coupon Code*

55-5605

REDEEM

Digital product only. No physical DVD will be shipped.

TABLE OF CONTENTS

Safety Instructions	3	Maintenance	17
Before You Begin	5	Conditioning Guidelines	18
Equipment Warning, Caution & Notice Labels ...	6	Warm-Up and Cool-Down	19
Hardware Identification Chart	7	Product Parts Drawing	20
Assembly Instructions	8	Parts List	21
Operational Instructions	12	Warranty	22
Workout Guide	14	Fax/Mail Ordering Form	23
Storage	17		

SAFETY INSTRUCTIONS

⚠ WARNING Cancer and Reproductive Harm www.P65Warnings.ca.gov

⚠ WARNING Consult your physician before starting this or any exercise program. This is especially important if you are over the age of 35, have never exercised before, are pregnant, or suffer from any health problem. Failure to follow all warnings and instructions could result in serious injury or death.

⚠ WARNING To reduce the risk of serious injury, read the following Safety Instructions before using the AeroPilates Precision Series Cadillac.

- The AeroPilates Precision Series Cadillac should only be used after a thorough review of the Owner's Manual by all exercisers and saved for future reference.
- Make sure that the product is properly assembled and tightened before use.
- We recommend that two people be available for assembly of this product.
- Keep children and pets away from the AeroPilates Precision Series Cadillac at all times. This product is for adult use only.
- When exercising on this product, do not exercise at an intensity that causes the product itself to move. This could result in damage to your joints and to the product.
- It is recommended that you place this product on an equipment mat.
- Set up and operate the AeroPilates Precision Series Cadillac on a solid level surface. Do not position the product on loose or uneven surfaces.
- Make sure that adequate space is available for access to and around the product.
- When folding or unfolding the AeroPilates Precision Series Cadillac, keep all children away from the AeroPilates Precision Series Cadillac and make sure your hands are clear of any folding or pinch point.
- Before using, always inspect the product for worn parts that should be replaced or loose parts that should be tightened.
- Always choose the workout which best fits your physical strength and flexibility level. Know your limits and train within them.
- Do not wear loose clothing while using the AeroPilates Precision Series Cadillac.
- Be careful to maintain your balance while assembling, mounting, using and dismounting the AeroPilates Precision Series Cadillac. Loss of balance may result in a fall or serious bodily injury.
- The AeroPilates Precision Series Cadillac should not be used by persons weighing over 350 pounds.
- The AeroPilates Precision Series Cadillac is for consumer use only. It is not for use in public or semipublic facilities.

EXTEND YOUR PARTS WARRANTY TO 180 DAYS FROM THE DATE OF PURCHASE. REGISTER YOUR PRODUCT.



**NEED HELP?
CONTACT US FIRST
1 (800) 375-7520
customer.care@staminaproducts.com**

Hi! From all of us here at Stamina Products, thank you for your purchase. We know that you have big fitness goals in mind and we are here to help you along. Call us, email us, or send us a message on Facebook. Be sure to contact us if you have any questions on your new product. We look forward to hearing from you!

With your body in mind,
Stamina Customer Care

To enact your extended warranty and to help us better serve you, please go online and register your new product.

register.staminaproducts.com

It is quick and easy to register online, but if you're a little old school or just need a reason to raise that little flag on your mailbox, fill out the info on the last page of this manual and mail it in.



ONLINE

customer.care@staminaproducts.com
www.staminaproducts.com



TELEPHONE

1 (800) 375-7520



FAX

(417) 889-8064



MAIL

Stamina Products, Inc.
ATTN: Customer Care
4435 West Manufacturers
Street, Springfield, MO 65803

 facebook.com/StaminaProducts
facebook.com/AeroPilates

CUSTOMER CARE HOURS:
Monday-Thursday, 7:30 AM-5:00 PM, Central Time
Friday, 8:00 AM-3:00 PM, Central Time

BEFORE YOU BEGIN

Thank you for choosing the AeroPilates Precision Series Cadillac. We take great pride in this quality product and hope it will provide many hours of quality exercise to make you feel better, look better, and enjoy life to its fullest.

It's a proven fact that a regular exercise program can improve your physical and mental health. Too often, our busy lifestyles limit our time and opportunity to exercise. The AeroPilates Precision Series Cadillac provides a convenient and simple method to begin your journey of getting your body in shape and achieving a happier and healthier lifestyle.

Before reading further, please review the drawing below and familiarize yourself with the parts that are labeled. Locate the serial decal on the product and write the serial number on the cover of the manual in the space provided. See page 6 for an image of the serial decal. Model

number and serial number are required when calling for assistance.

Read this manual carefully before using the AeroPilates Precision Series Cadillac.

Providing you with a quality product is Stamina's top priority. However, sometimes there could be a missing or incorrectly sized part. If you have any questions or problems with the parts included with your AeroPilates Precision Series Cadillac, please do not return the product. Contact us **FIRST!**

If a part is missing or defective, please contact Customer Care for assistance. Call us toll free at 1-800-375-7520 (in the U.S.) or live chat on staminaproducts.com. Our Customer Care Staff is available to assist you from 7:30 A.M. to 5:00 P.M. (Central Time) Monday through Thursday and 8:00 A.M. to 3:00 P.M. (Central Time) on Friday.

Be sure to have the name and model number of the product available when you contact us.

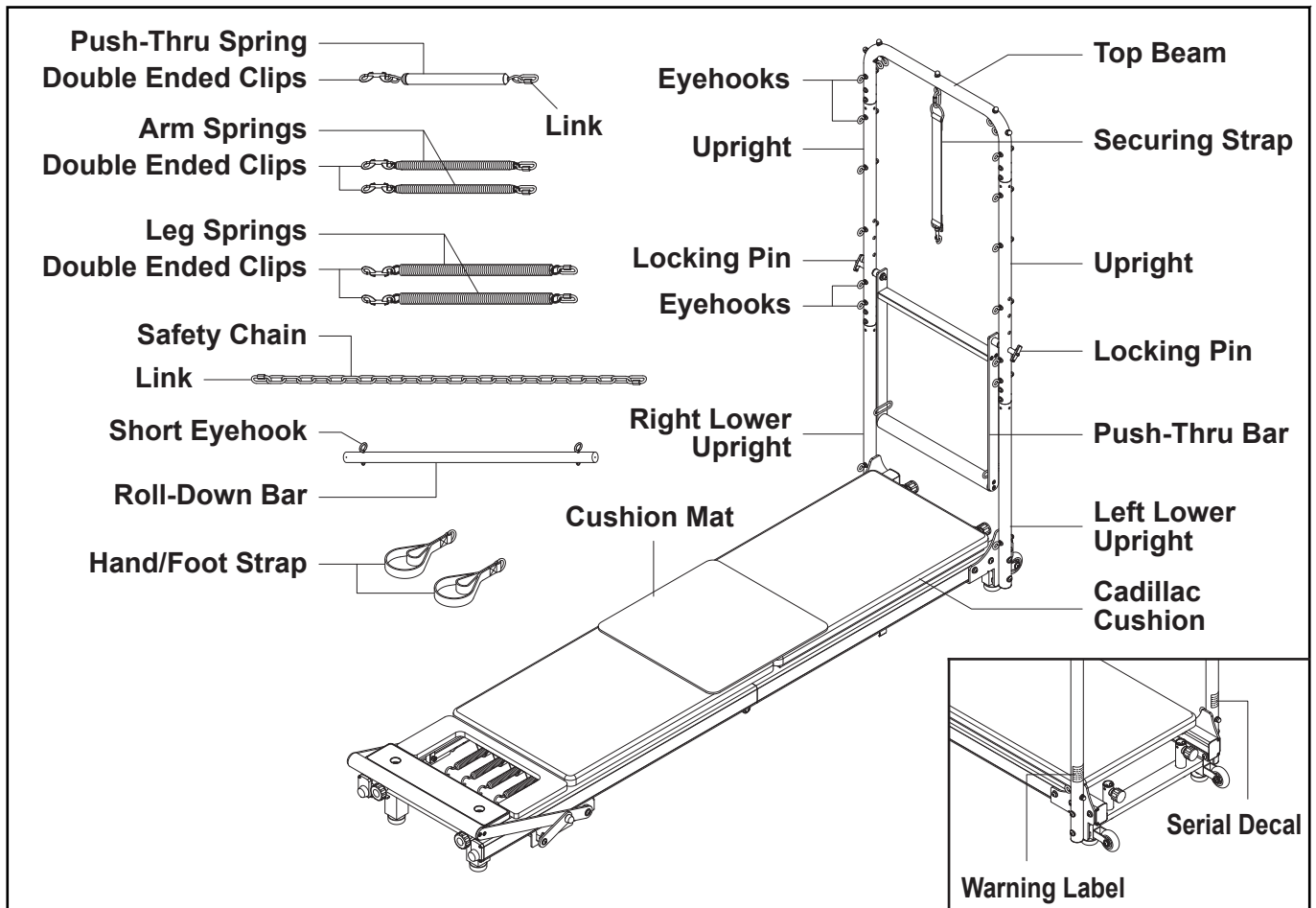

THE FOLLOWING TOOLS ARE INCLUDED FOR ASSEMBLY:

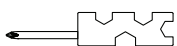

Combination Wrench



Allen Wrench (4mm)



Allen Wrench (6mm)

EQUIPMENT WARNING, CAUTION & NOTICE LABELS

This chart is provided to help identify the warning, caution, and notice labels on the AeroPilates Precision Series Cadillac. Please take a moment to familiarize yourself with all of the warning, caution, and notice labels.

WARNING LABEL(45)



PUSH-THRU BAR CAUTION DECAL(46)



SERIAL DECAL(47)



To best serve you, our Customer Care Representatives will need your serial number. For quick access, write in your serial number on the cover of the manual.

HARDWARE IDENTIFICATION CHART

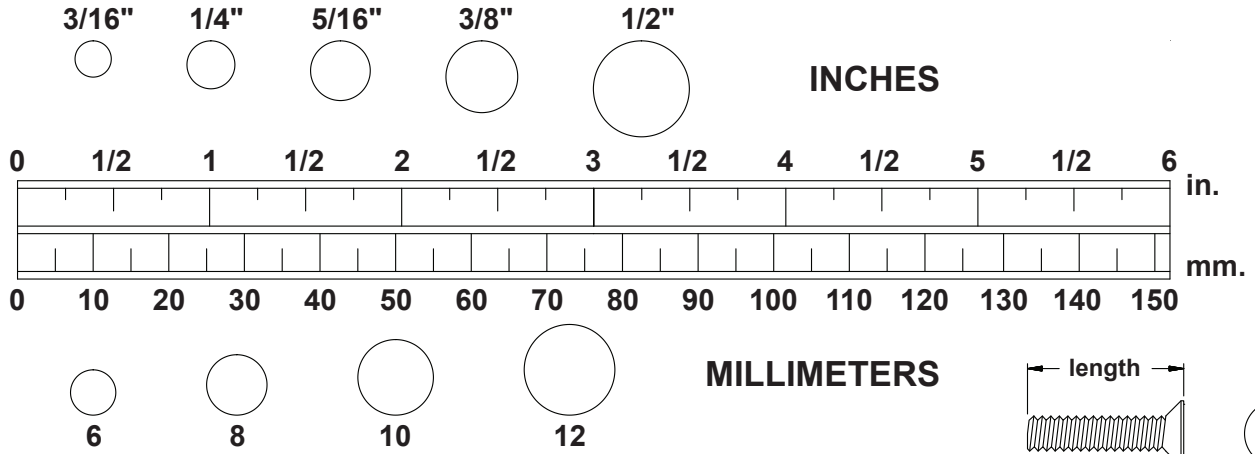

This chart is provided to help identify the hardware used in the assembly process. Place the washers or the ends of the bolts or screws on the circles to check for the correct diameter. Use the small scale to check the length of the bolts and screws.

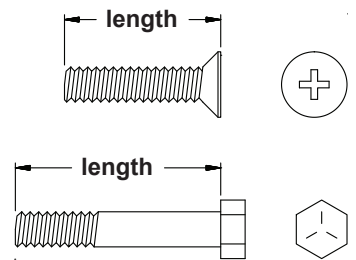

NOTICE: The length of all bolts and screws, except those with flat heads, is measured from below the head to the end of the bolt or screw. Flat head bolts and screws are measured from the top of the head to the end of the bolt or screw.

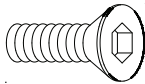
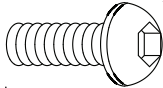
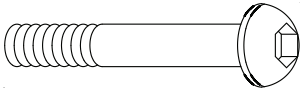

After unpacking the unit, open the hardware bag and make sure that you have all the following items. Some hardware may be already attached to the part.

	Part Number and Description	Qty
	26 Bolt, Flat Socket Head (M6 x 1 x 20mm)	8
	27 Bolt, Button Head (M6 x 1 x 15mm)	16
	29 Bolt, Button Head (M8 x 1.25 x 25mm)	10
	30 Bolt, Button Head (M8 x 1.25 x 60mm)	2
	41 Bolt, Button Head (M8 x 1.25 x 70mm)	2
	31 Arc Washer (M6)	16
	37 Arc Washer (M8)	4

ASSEMBLY INSTRUCTIONS

Place all parts from the box in a cleared area and position them on the floor in front of you. Remove all packing materials from your area and place them back into the box. Do not dispose of the packing materials until assembly is completed. Read each step carefully before beginning. If you are missing a part, please go to staminaproducts.com under the Customer Care section and order the part needed, e-mail us at customer.care@staminaproducts.com, or call us toll free at 1-800-375-7520 (in the U.S.). Our Customer Care Staff is available to assist you from 7:30 A.M. to 5:00 P.M. (Central Time) Monday through Thursday and 8:00 A.M. to 3:00 P.M. (Central Time) on Friday.

Some product parts are fit tested at the factory to ensure proper fit and alignment. Marks in the paint may be noticeable, but are not an indication of damage.

NOTE: The **AeroPilates Precision Series Reformer (55-5615)** is not included with the **AeroPilates Precision Series Cadillac (55-5605)**.

STEP 1

Hook one of the **TENSION SPRINGS** to the eyehook. Adjust the **FOOTBAR** to the lowest position. Pull to remove the **SHOULDER PADS**.

STEP 2

Unscrew and pull the **SPRING KNOBS** to remove the **PULLEY RISERS** from the **AeroPilates Precision Series Reformer**.

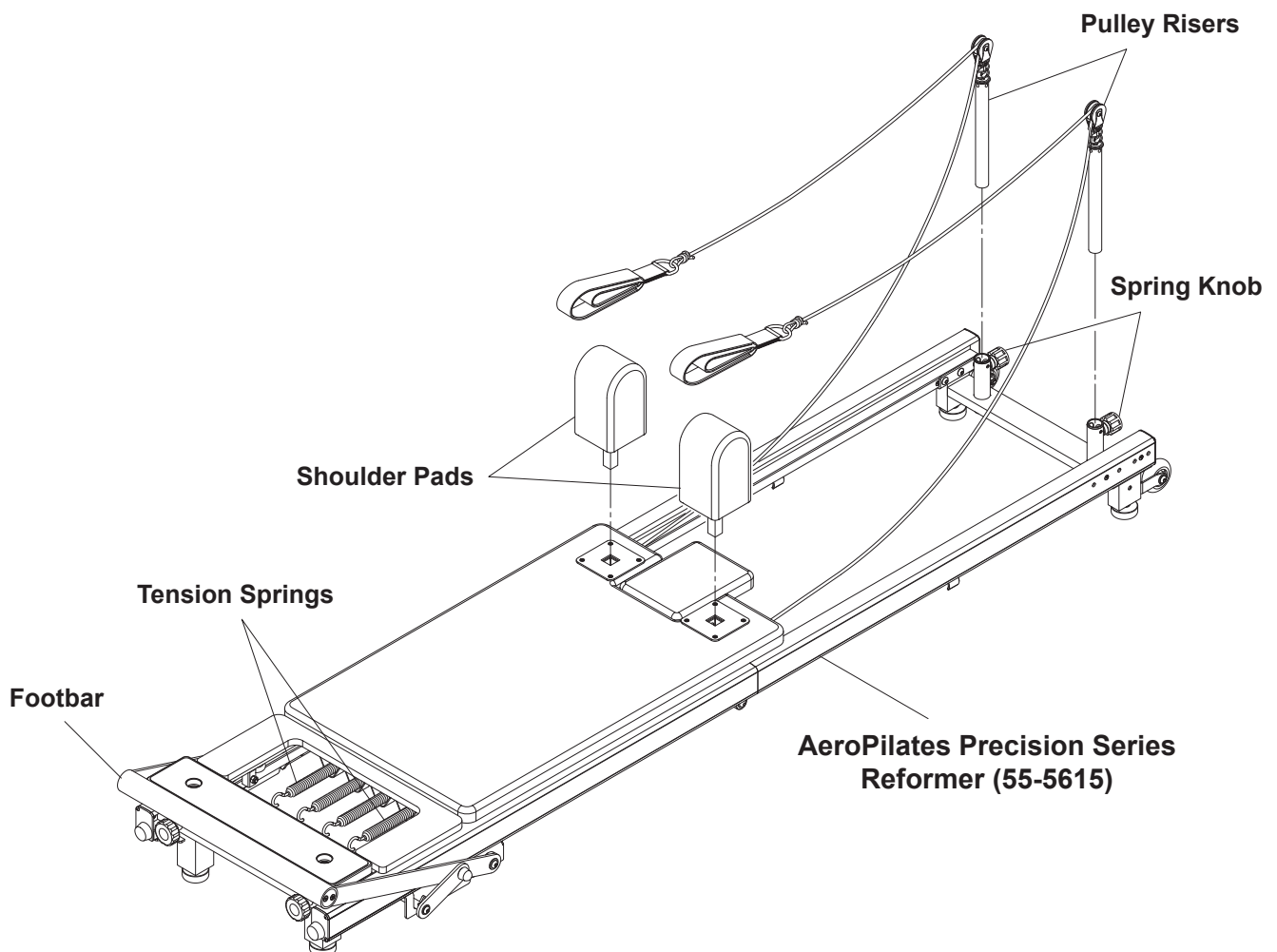

ASSEMBLY INSTRUCTIONS

NOTE: DO NOT SECURELY TIGHTEN ALL BOLTS UNTIL STEP 5.

STEP 3

Attach the **LEFT LOWER UPRIGHT(3)** to the **REAR LEFT RAIL** with **BUTTON HEAD BOLTS(M8x1.25x25mm)(29)**. Attach the **LEFT LOWER UPRIGHT(3)** to the **REAR LEFT RAIL** and **REAR FRAME** with **BUTTON HEAD BOLT(M8x1.25x60mm)(30)**, **BUTTON HEAD BOLT(M8x1.25x60mm)(41)**, and **ARC WASHERS(M8)(37)**. Repeat on the right side.

RIGHT

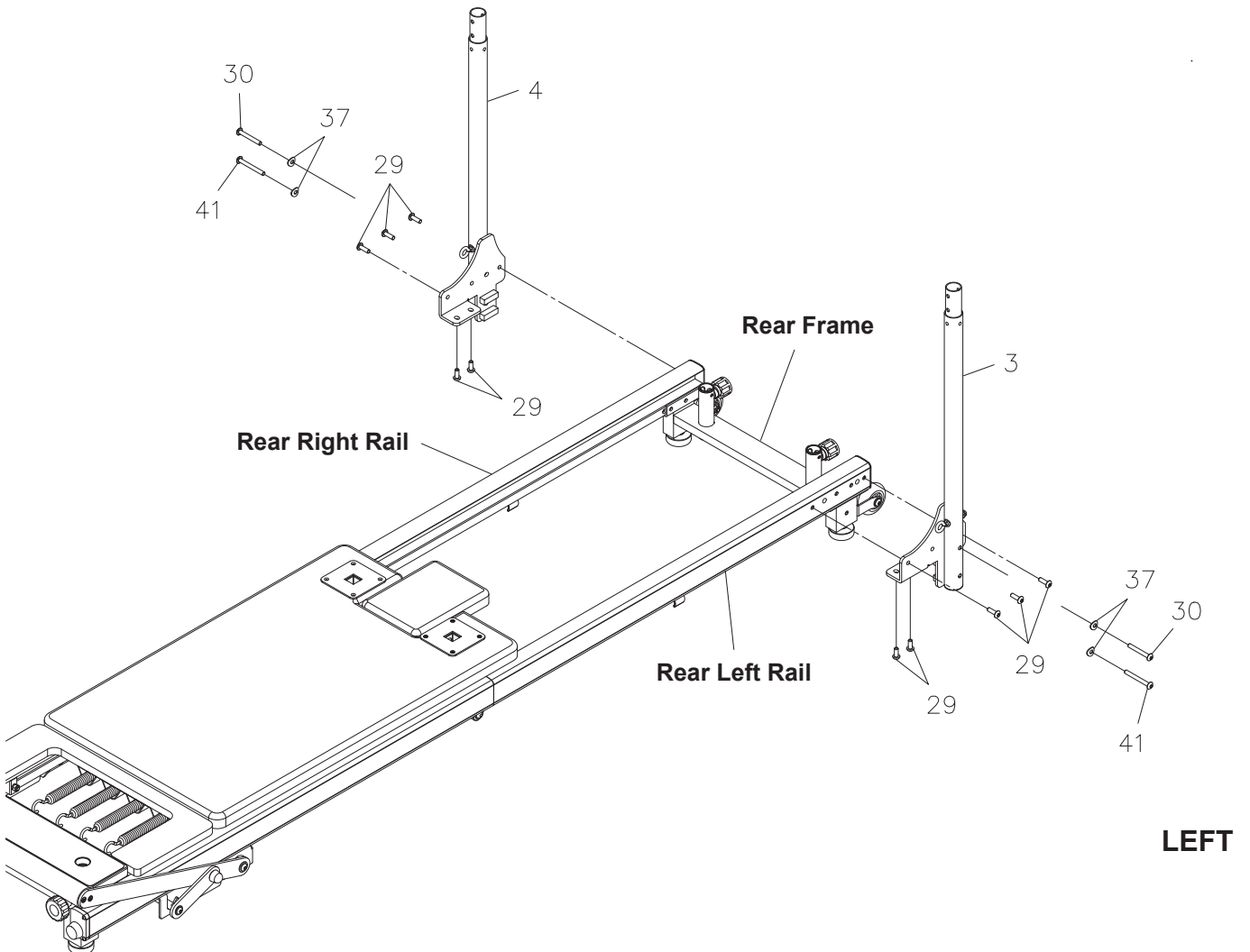

ASSEMBLY INSTRUCTIONS

STEP 4

Make the **EYEHOOKS(21)** point to the front. Insert the **UPRIGHTS(2)** onto the **LEFT** and **RIGHT LOWER UPRIGHTS(3, 4)** and secure with **BUTTON HEAD BOLTS(M6x1x15mm)(27)** and **ARC WASHERS(M6)(31)**.

STEP 5

Insert the **TOP BEAM(1)** onto the **UPRIGHTS(2)** and secure with **BUTTON HEAD BOLTS(M6x1x15mm)(27)** and **ARC WASHERS(M6)(31)**.

Securely tighten all bolts from STEP 3. Then securely tighten all of the bolts from STEP 3 to STEP 5.

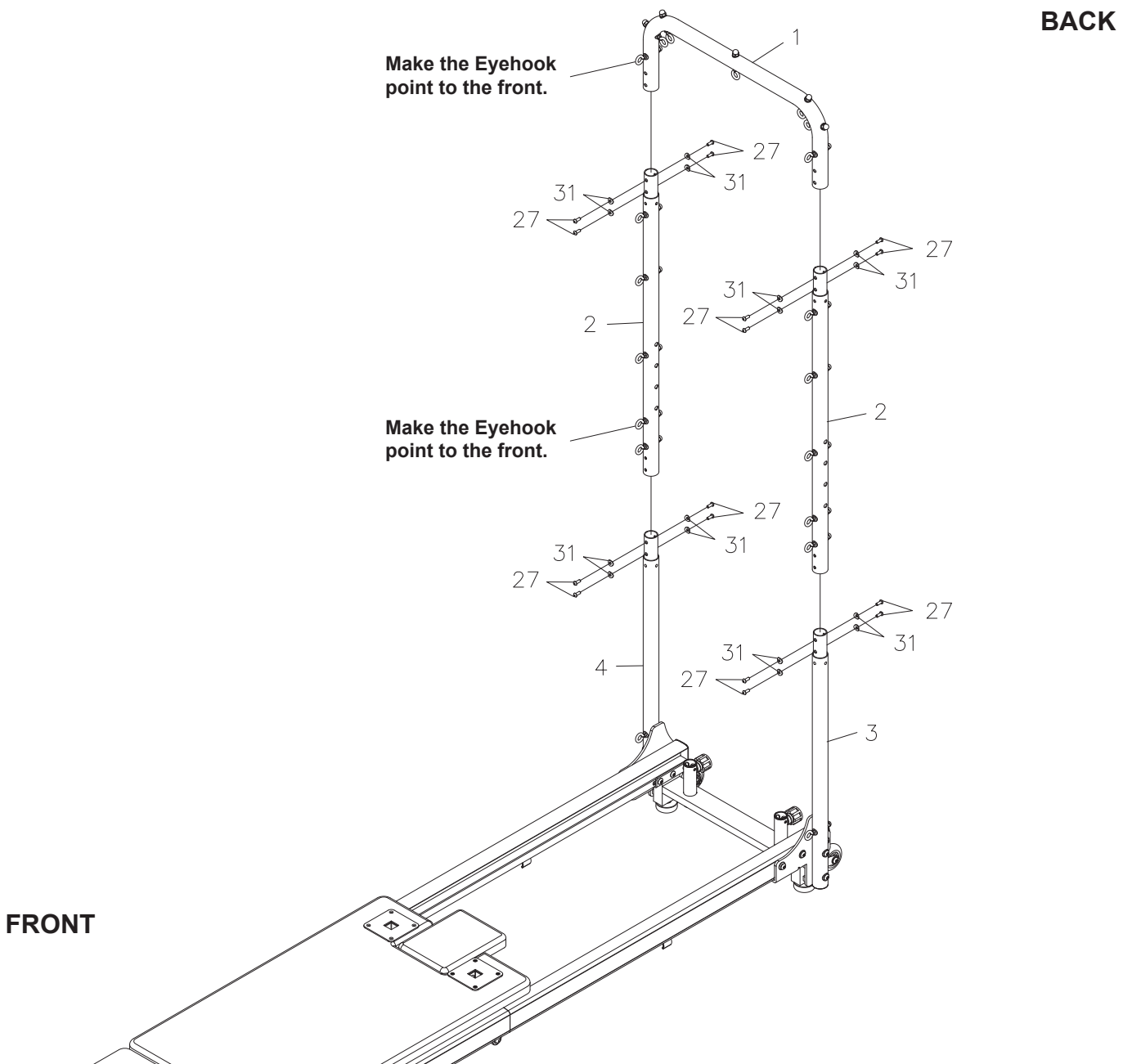

ASSEMBLY INSTRUCTIONS

STEP 6

- NOTE:** 1. There are four adjustment holes in each **UPRIGHT(2)** that allow you to attach the **PUSH-THRU BAR(5)** to four different heights.
2. Push in the button on the “T” end of the **LOCKING PIN(27)** – see inset – to release the Steel Ball on the other end of the pin. Then you can insert the **LOCKING PIN(17)** into the adjustment hole. Push the button to remove the pin.
3. Always use **SECURING STRAP(14)** to keep the **PUSH-THRU BAR(5)** in a secure position when not in use.

Refer to illustration A. Bolt the **PUSH-THRU BARS(5)**, **CROSSING BAR(6)**, and **HANDLEBAR(7)** together with **FLAT SOCKET HEAD BOLTS(M6x1x20mm)(26)**. Attach the **PUSH-THRU BAR ASSEMBLY(5)** to one of the adjustment holes in the **UPRIGHTS(2)** with the **LOCKING PINS(17)**. Always make sure **SAFETY CHAIN(25)** is connected with the **LINKS(24)** when the **PUSH-THRU BAR(5)** is in use. Attach the **SECURING STRAP(14)** onto the center **EYEHOOK(21)** with the **LINK(24)** on the top of the **TOP BEAM(1)**.

STEP 7: Angle the **HEADREST**. Carefully place the **CADILLAC CUSHION(8)** onto the Aluminum Rails. Adjust the **HEADREST** back to flat position. There are some hard parts around the **HEADREST** area. Use the **CUSHION MAT(33)** to cover.

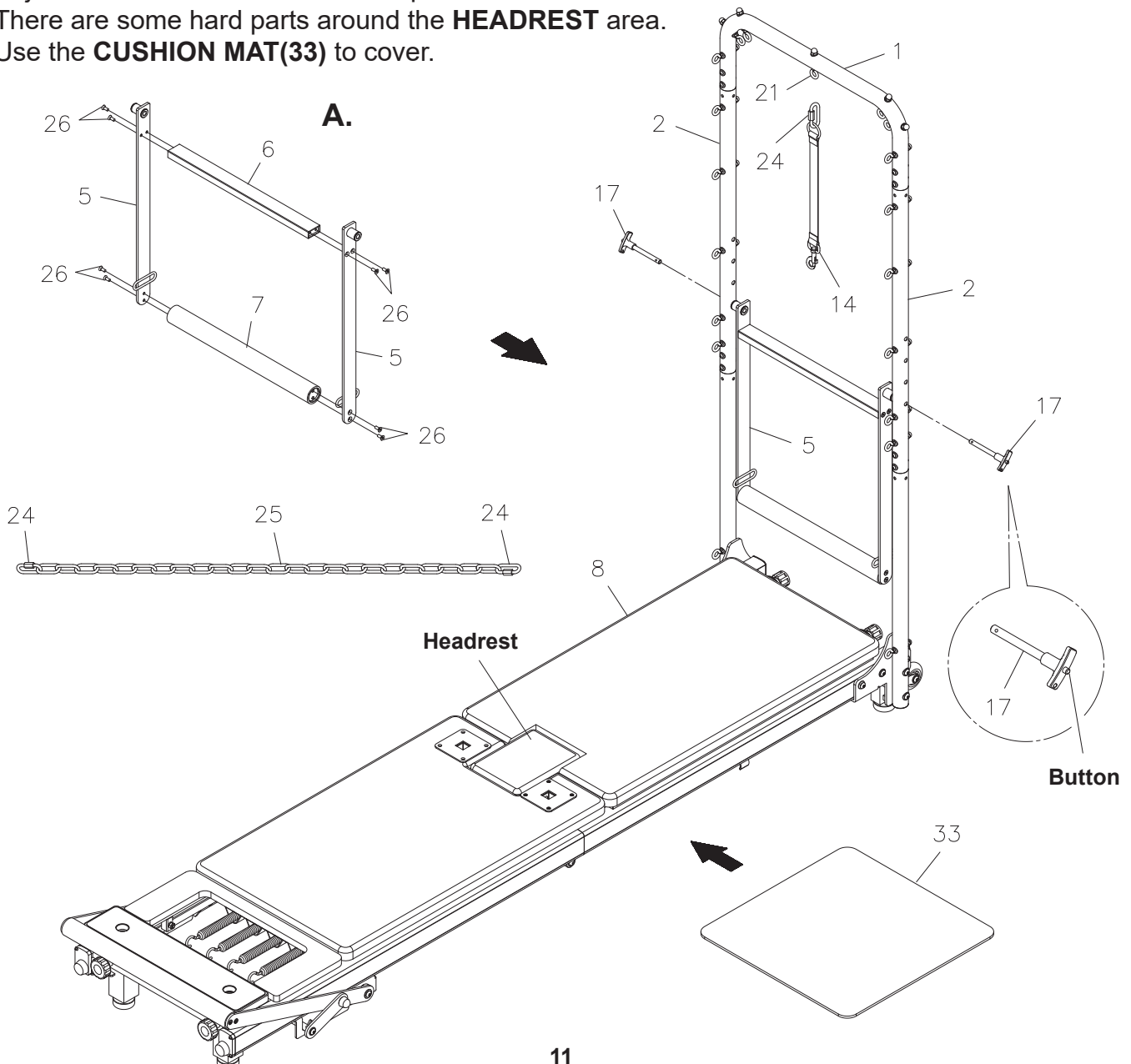

OPERATIONAL INSTRUCTIONS

TO USE THE ACCESSORIES:

NOTE: Prior to adding the **PUSH-THRU SPRING(19)** to the **PUSH-THRU BAR(5)** make sure the **SAFETY CHAIN(25)** is at a length that allows enough clearance to get under the **PUSH-THRU BAR(5)**.

PUSH-THRU BAR

When doing exercises that require the spring resistance to come from above the bar, attach the **PUSH-THRU SPRING(19)** to the hook on the upper side of the **PUSH-THRU BAR(5)** with the **DOUBLE ENDED CLIP(23)**. Attach the other end of the **PUSH-THRU SPRING(19)** to one of the eyehooks on the **UPRIGHT(2)** with the **LINK(24)**. When doing exercises that require the spring resistance to come from below the bar, attach the **PUSH-THRU SPRING(19)** to the hook on the underside of the **PUSH-THRU BAR(5)** with the **DOUBLE ENDED CLIP(23)**. Attach the other end of the **PUSH-THRU SPRING(19)** to one of the eyehooks on the **LOWER UPRIGHT(3 or 4)** with the **LINK(174)**. Be sure that the **SAFETY CHAIN(25)** is always connected to the **PUSH-THRU BAR(5)** when in use.

⚠ CAUTION When using the **PUSH-THRU SPRING(19)** from below, you must hook the spring onto the **LOWER UPRIGHT(3 or 4)** with the **LINK(24)** and make sure the **SAFETY CHAIN(25)** is connected. Ensure that the **SPRING SLEEVE(16)** which covers the **PUSH-THRU SPRING(19)** is moved over the lower part of the spring to avoid pulling the user's hair or clothing.

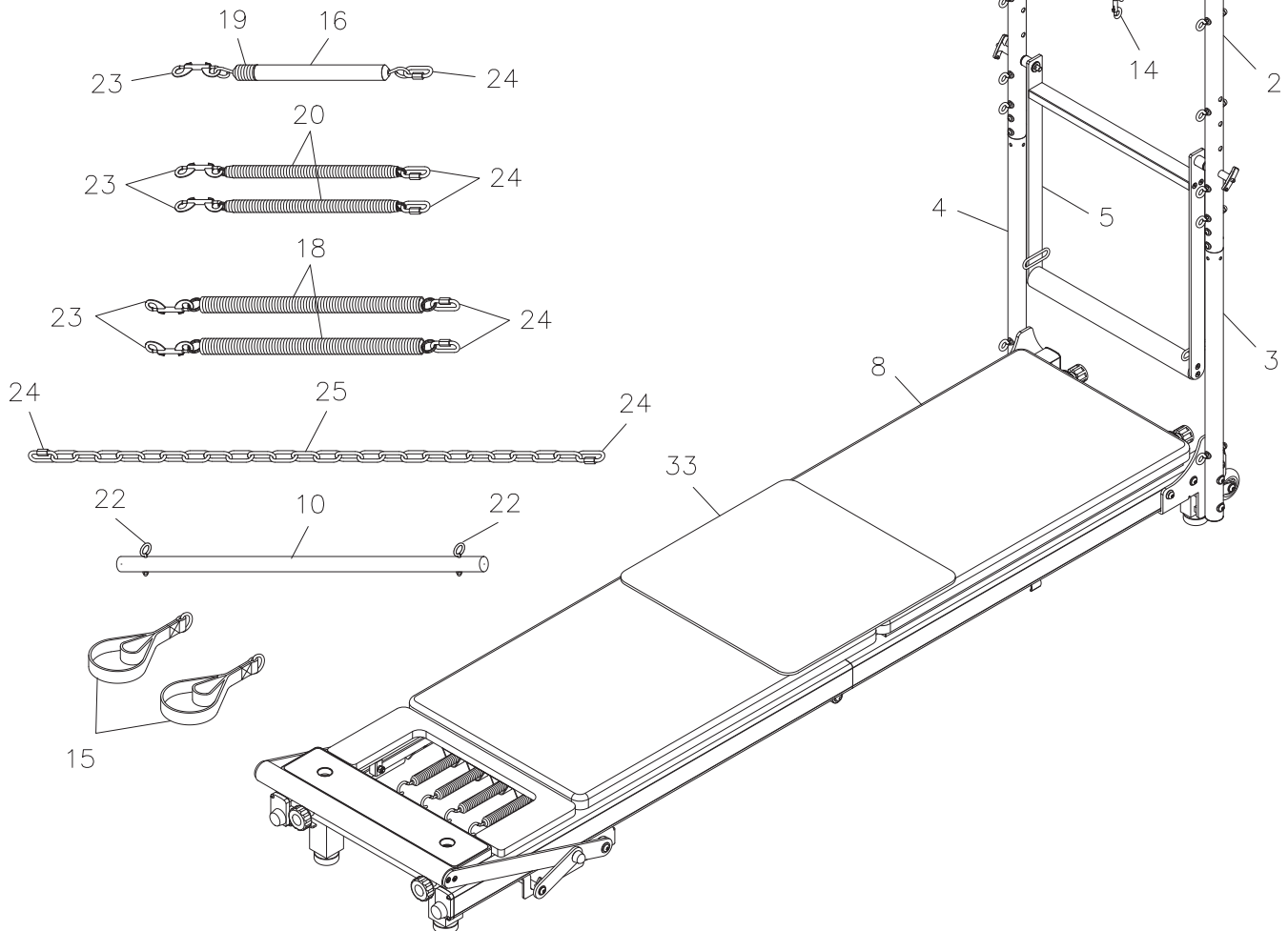

OPERATIONAL INSTRUCTIONS

SAFETY CHAIN

The **SAFETY CHAIN(25)** must be used as follows:

When using the **PUSH-THRU BAR(5)** with spring attached from below to do arm or leg exercises, the chain must be attached to the hook on the upper side of the bar on the same side as the spring and to an **EYEHOOK(21)**.

ROLL-DOWN BAR

The **ROLL-DOWN BAR(10)** attaches via the **ARM SPRINGS(20)** to the eyehooks on the **TOP BEAM(1)** between the two **UPRIGHTS(2)** with the **LINKS(24)**. Attach the springs to the **ROLL-DOWN BAR(10)** with the **DOUBLE ENDED CLIPS(23)**. **Ensure the links and clips are completely closed and secure.**

CAUTION: ROLL-DOWN BAR(10) can release at high velocity due to spring tension. Make sure a secure grip is used at all times.

ARM EXERCISES

Attach **ARM SPRINGS(20)** to eyehooks at desired height with the **LINKS(24)**. Attach the other ends of the springs to the **HAND/FOOT STRAPS(15)** with the **DOUBLE ENDED CLIPS(23)**. **Ensure the links and clips are completely closed and secured.**

LEG EXERCISES

Attach **LEG SPRINGS(18)** to eyehooks at desired height with the **LINKS(24)**. Attach the other ends of the springs to the **HAND/FOOT STRAPS(15)** with the **DOUBLE ENDED CLIPS(23)**. **Ensure the links and clips are completely closed and secured.**

PRECISION SERIES CADILLAC

Leg Springs



Circles - Lie on back with head near tower, approximately an arms length away, hands holding tower, or arms by side holding Cadillac cushion. Feet in straps of leg springs. Begin with legs near a 45 degree angle and turned out at hip joint.

Inhale, moving from hip, bring feet up towards ceiling, then open legs out to sides
Exhale, circle legs around to starting position.
Complete 5-10 repetitions and then reverse circles.



Side Lying Leg Lifts - Lie on one side with head towards tower. Bottom arm holding tower or supporting head and neck. Bottom leg straight or bent slightly to assist with balance and stability. Begin with top leg foot in strap of leg spring and leg straight in line with the body.

Inhale to point foot and lift leg slightly higher than hip height
Exhale flex foot and lower leg back to starting position
Complete 5-10 repetitions on both sides.

Push Through Bar with Springs from Below

Adjust push thru bar on tower to best fit your height. Attach safety chain to one eye hook on top and spring from the bottom to bottom eye hook.



Chest Press - Lie under bar with shoulders approximately under bar. Knees bent, feet flat on cushion. Hands on bar with elbows out to sides.

Inhale to prepare
Exhale to press the bar away
Inhale to control the bar back to starting position

Exercise can be repeated with elbows by sides/ribcage
Complete 5-10 repetitions.



Leg Press - Lie under bar with one foot, toes wrapped around bar in parallel position. Other leg can be straight or bent with the foot flat on cushion.

Inhale to press bar away, straightening leg
 Exhale to flex the foot and stretch calf
 Inhale to point foot
 Exhale to bend knee and return to starting position

Complete 5-10 repetitions on each leg

Push Through Bar Springs from Above

Attach 1 or 2 arm springs to the push through bar top eye hooks



Teaser Prep - Lie on back with head towards tower. Hands holding bar overhead. Knees bent, feet on cushion.

Inhale to bring bar in front of face and nod the head
 Exhale, rolling up to sitting position and lift legs, straightening knees to the teaser V
 Inhale, begin roll back down
 Exhale, bend knees, continue to roll down, placing feet back on cushion and pressing bar overhead
 Complete 5-10 repetitions.



Swan Dive - Begin on stomach, head towards tower, arms holding bar overhead, legs wider than hips and turned out.

Inhale to lift into back extension off the cushion keeping arms straight and abs engaged
 Exhale to lower back to starting position
 Complete 5-10 repetitions then finish by carefully returning bar back up and pressing back into a shell stretch

Arm Springs



Bicep Curls - Standing with good posture on Cadillac cushion facing tower. Springs attached to eye hooks that most closely line up with height of shoulders. Arms lifted up in line with shoulders.

Inhale to prepare
Exhale to flex elbow and curl biceps
Inhale to return to starting position
Complete 5-10 repetitions.



Salute - Stand facing away from tower, slight lean forward from hips, hands at forehead with springs passing over the shoulders

Inhale to prepare
Exhale to lengthen elbows and press hands away from forehead
Inhale to bring elbows to starting position
Complete 5-10 repetitions.

Roll Down Bar



Roll Down - Seated on Cadillac cushion facing tower, hands on roll down bar at inside of springs. Feet with toes resting up against tower uprights

Inhale to prepare
Exhale to press gently down on bar and begin to roll down slowly, articulating each vertebrae onto the cushion until head rests on cushion.
Inhale to nod the head and begin to slowly roll back up
Exhale to continue to roll the spine off the cushion, returning to starting position
Complete 5-10 repetitions.



Port de bras Prep - Seated on Cadillac cushion facing tower, feet with toes resting against tower uprights. One hand placed at center of bar, the other hand underneath bar.

Inhale to rotate spine to one side

Exhale keeping the slight rotation and roll down to the cushion articulating the spine

Inhale to nod head

Exhale to roll back up maintaining the slight rotation and return to starting position

Complete 5-10 repetitions on each side.

STORAGE

- To store the AeroPilates Precision Series Cadillac, simply keep it in a clean dry place.
- It is recommended that two people be available to move the AeroPilates Precision Series Cadillac and AeroPilates Precision Series Reformer (55-5615).
- To move the AeroPilates Precision Series Cadillac and AeroPilates Precision Series Reformer (55-5615): First, Move the **PLATFORM** to the back end. Second, grasp the **FRONT FRAME** and lift the unit from the front. Third, roll the AeroPilates Precision Series Reformer (55-5615) on the **MOVING WHEELS** that are attached to the **REAR FRAME**.

MAINTENANCE

The safety and integrity designed into the AeroPilates Precision Series Cadillac can only be maintained when the AeroPilates Precision Series Cadillac is regularly examined for damage and wear. Special attention should be given to the following:

- It is the sole responsibility of the user/owner to ensure that regular maintenance is performed.
- Worn or damaged components must be replaced immediately or the AeroPilates Precision Series Cadillac removed from service until repair is made.
- Verify that the **CAUTION LABEL(45)** is present and legible. Replace the **CAUTION LABEL(45)** if it is missing or damaged.
- Check the **HAND/FOOT STRAPS(15)** for damage. Replace damaged parts.
- Check the **FOAM GRIP(13)**. Replace if damaged or worn.
- Check the **CADILLAC CUSHION(8)** and **CUSHION MAT(33)**. Replace if damaged or worn.
- Only Stamina Products supplied components should be used to maintain/repair the AeroPilates Precision Series Cadillac.
- Keep your AeroPilates Precision Series Cadillac clean by wiping with an absorbent cloth after use.

CONDITIONING GUIDELINES

How you begin your exercise program depends on your physical condition. If you have been inactive for several years or are severely overweight, start slowly and increase your workout time gradually. Increase your workout intensity gradually by monitoring your heart rate while you exercise.

Remember to follow these essentials:

- Have your doctor review your training and diet programs.
- Begin your training program slowly with realistic goals that have been set by you and your physician.
- Warm up before you exercise and cool down after you work out.
- Take your pulse periodically during your workout and strive to stay within a range of 60% (lower intensity) to 90% (higher intensity) of your maximum heart rate zone. Start at the lower intensity, and build up to higher intensity as you become more aerobically fit.
- If you feel dizzy or lightheaded you should slow down or stop exercising.

Initially you may only be able to exercise within your target zone for a few minutes; however, your aerobic capacity will improve over the next six to eight weeks. It is important to pace yourself while you exercise so you don't tire too quickly.

To determine if you are working out at the correct intensity, use a heart rate monitor or use the table below. For effective aerobic exercise, your heart rate should be maintained at a level between 60% and 90% of your maximum heart rate. If just starting an exercise program, work out at the low end of your target heart rate zone. As your aerobic capacity improves, gradually increase the intensity of your workout by increasing your heart rate.

Measure your heart rate periodically during your workout by stopping the exercise but continuing to move your legs or walk around. Place two or three fingers on your wrist and take a six second heartbeat count. Multiply the results by ten to find your heart rate. For example, if your six second heartbeat count is 14, your heart rate is 140 beats per minute. A six second count is used because your heart rate will drop rapidly when you stop exercising. Adjust the intensity of your exercise until your heart rate is at the proper level.

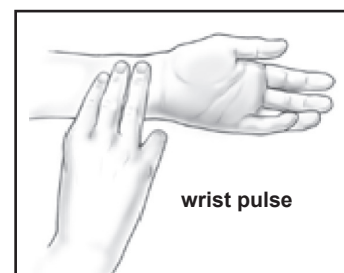

Target Heart Rate Zone Estimated by Age*

Age	Target Heart Rate Zone (55%-90% of Maximum Heart Rate)	Average Maximum Heart Rate 100%
20 years	110-180 beats per minute	200 beats per minute
25 years	107-175 beats per minute	195 beats per minute
30 years	105-171 beats per minute	190 beats per minute
35 years	102-166 beats per minute	185 beats per minute
40 years	99-162 beats per minute	180 beats per minute
45 years	97-157 beats per minute	175 beats per minute
50 years	94-153 beats per minute	170 beats per minute
55 years	91-148 beats per minute	165 beats per minute
60 years	88-144 beats per minute	160 beats per minute
65 years	85-139 beats per minute	155 beats per minute
70 years	83-135 beats per minute	150 beats per minute

* For cardiorespiratory training benefits, the American College of Sports Medicine recommends working out within a heart rate range of 55% to 90% of maximum heart rate. To predict the maximum heart rate, the following formula was used: $220 - \text{Age} = \text{predicted maximum heart rate}$

WARM-UP and COOL-DOWN

Warm-Up The purpose of warming up is to prepare your body for exercise and to minimize injuries. Warm up for two to five minutes before strength training or aerobic exercising. Perform activities that raise your heart rate and warm the working muscles. Activities may include brisk walking, jogging, jumping jacks, jump rope, and running in place.

Cool-Down The purpose of cooling down is to return the body to its normal, or near normal, resting state at the end of each exercise session. A proper cool-down slowly lowers your heart rate and allows blood to return to the heart. Your cool down should be completed after each strength training session.

PARTS LIST

PART#	PART NAME	QTY
1	Top Beam	1
2	Upright	2
3	Left Lower Upright	1
4	Right Lower Upright	1
5	Push-Thru Bar	2
6	Crossing Bar	1
7	Handlebar	1
8	Cadillac Cushion	1
9	Wooden Guide	2
10	Roll-Down Bar	1
11	Plastic Bushing	4
12	Round Plug (ø38.1mm)	2
13	Foam Grip (ø36 x ø43 x 472mm)	1
14	Securing Strap	1
15	Hand/Foot Strap	2
16	Spring Sleeve	1
17	Locking Pin	2
18	Leg Spring (ø2.3 x ø29.2 x 610mm)	2
19	Push-Thru Spring (ø2.67 x ø29 x 500mm)	1
20	Arm Spring (ø2.0 x ø23 x 477mm)	2
21	Eyehook (ø6 x ø26 x 80mm, M6 x 1 x 54mm)	19
22	Short Eyehook (ø6 x ø26 x 74mm, M6 x 1 x 47mm)	2
23	Double Ended Clip	5
24	Link	8
25	Safety Chain (ø7 x 27mm x 52mm x 24 links)	1
26	Bolt, Flat Socket Head (M6 x 1 x 20mm, with threadlocker)	8
27	Bolt, Button Head (M6 x 1 x 15mm, with threadlocker)	16
28	Bolt, Button Head (M6 x 1 x 20mm)	8
29	Bolt, Button Head (M8 x 1.25 x 25mm)	10
30	Bolt, Button Head (M8 x 1.25 x 60mm)	2
31	Arc Washer (M6)	58
32	Washer (M6)	8
33	Cushion Mat	1
34	Bolt, Flat Socket Head (M6 x 1 x 15mm, with threadlocker)	3
35	Nut (M6 x 1)	21
36	Acorn Nut (M6 x 1)	21
37	Arc Washer (M8)	4
38	Combination Wrench	1
39	Allen Wrench(4mm)	1
40	Allen Wrench(6mm)	1
41	Bolt, Button Head (M8 x 1.25 x 70mm)	2
42	Left Plastic Pad	1
43	Right Plastic Pad	1
44	Support Plate	1
45	Warning Label	1
46	Push-Thru Bar Caution Decal	1
47	Serial Decal	1
48	Manual	1

LIMITED WARRANTY

MODEL 55-5605

WARRANTY

Stamina Products, Inc. ("Stamina") warrants to the original purchaser that this product will be free from defects in materials and workmanship that arise under normal use, service, proper assembly and proper operation in accordance with product warnings/instructions for a period of 90 days on the parts and five years on the frame from the date of the original purchase from an authorized retailer. **THIS WARRANTY SHALL NOT APPLY TO ANY PRODUCT WHICH HAS BEEN SUBJECT TO COMMERCIAL USE, ABUSE, MISUSE, ALTERATION OF ANY KIND OR TO ANY DEFECT OR CHANGE CAUSED BY IMPROPER ASSEMBLY, REPAIR, REPLACEMENT, SUBSTITUTION OR USE WITH PARTS NOT PROVIDED BY STAMINA.** Commercial use includes use of product in athletic clubs, health clubs, spas, gyms, and all other public or semipublic facilities whether or not the product's use is in furtherance of a profit making enterprise, and all other use which is not for personal purposes.

To implement this limited warranty, send a written notice stating your name, date, and place of purchase and a brief description of the defect along with your receipt to Stamina Products, Inc. 4435 West Manufacturers Street, Springfield, Missouri, USA, MO 65803, or email us at customer.care@staminaproducts.com, or call us at 1-800-375-7520. If the defect is covered under this limited warranty, you will be requested to return the product or part to us for free repair or replacement at our option.

NO ACTION FOR BREACH OF THIS LIMITED WARRANTY MAY BE COMMENCED MORE THAN ONE (1) YEAR AFTER THE DATE THE ALLEGED BREACH WAS OR SHOULD HAVE BEEN DISCOVERED. NO ACTION FOR BREACH OF ANY IMPLIED WARRANTY (INCLUDING MERCHANTABILITY AND FITNESS FOR A PARTICULAR PURPOSE) MAY BE COMMENCED MORE THAN ONE (1) YEAR AFTER DELIVERY OF THE PRODUCT TO THE PURCHASER. These warranties are not transferable. **IF ANY PART OF THE PRODUCT IS NOT IN COMPLIANCE WITH THIS LIMITED WARRANTY OR ANY IMPLIED WARRANTY, THE REMEDY OF REPAIR OR REPLACEMENT IS THE EXCLUSIVE REMEDY.** If any claim is made under this limited warranty or any implied warranty, Stamina reserves the right to require the product to be returned for inspection, at the purchaser's expense, to Stamina's premises in Springfield, Missouri. Return of the enclosed warranty registration card is not required for warranty coverage, but is merely a way of establishing the date and place of purchase.

Stamina **SHALL NOT BE LIABLE FOR THE LOSS OF USE OF ANY PRODUCT, LOSS OF TIME, INCONVENIENCE, COMMERCIAL LOSS OR ANY OTHER INDIRECT, CONSEQUENTIAL, SPECIAL OR INCIDENTAL DAMAGES DUE TO BREACH OF THE ABOVE WARRANTY OR ANY IMPLIED WARRANTY.**

THIS LIMITED WARRANTY IS THE ONLY EXPRESS WARRANTY. NO ORAL OR WRITTEN INFORMATION GIVEN BY STAMINA, ITS AGENTS OR EMPLOYEES, SHALL CREATE A WARRANTY OR IN ANY WAY INCREASE THE SCOPE OF THIS WARRANTY. This warranty gives you specific legal rights, and you may also have other legal rights which vary from state to state. **ANY OTHER RIGHT WHICH YOU MAY HAVE, INCLUDING ANY IMPLIED WARRANTY OF MERCHANTABILITY OR FITNESS FOR A PARTICULAR PURPOSE, IS LIMITED IN DURATION TO THE DURATION OF THIS WARRANTY.**

The laws in some states affect the disclaimer or limitation of implied warranties and consequential and incidental damages. If any such law is found applicable, the foregoing disclaimers and limitations of and on implied warranties and consequential and incidental damages shall be deemed to be modified to the extent necessary to comply with applicable law.

TO CONTACT CUSTOMER CARE

For your convenience, Stamina's customer care representatives can be reached by email at customer.care@staminaproducts.com or by phone at 1-800-375-7520 (in the U.S.). Our customer care representatives are available Monday through Thursday from 7:30 a.m. until 5:00 p.m., and Friday 8:00 a.m. until 3 p.m. Central Time.



**ONLINE
CUSTOMER CARE**
customer.care@staminaproducts.com
www.staminaproducts.com



**TELEPHONE
CUSTOMER CARE**
Tel: 1 (800) 375-7520



**FAX
CUSTOMER CARE**
Fax: (417) 889-8064



MAIL
STAMINA PRODUCTS, INC.
ATTN: Customer Care
4435 West Manufacturers Street, Springfield, MO 65803

Would you like to receive email information or special offers from Stamina Products? Register at contact.staminaproducts.com

TO REGISTER YOUR PRODUCT

To enact your warranty, please register your product by going to register.staminaproducts.com. Please have your product model number (printed on the cover of this owner's manual) and the serial number (printed on the black and white sticker on your product) ready.

If you don't have internet access, you can call customer care at 1-800-375-7520, or fill out and mail the product registration form below to Stamina Products, Inc.; 4435 West Manufacturers Street, Springfield, MO 65803.

PRODUCT REGISTRATION FORM	Stamina Products, Inc. 4435 West Manufacturers Street, Springfield, MO 65803
Model Number:	Serial Number:
Product Name:	
Place Purchased:	
Date of Purchase:	Purchase Price:
First Name:	Last Name:
City:	State: Zip Code:
Email Address:	Phone #: ()
Would you like to receive email information or special offers from Stamina Products?* <input type="checkbox"/> Yes <input type="checkbox"/> No *If yes, be sure your email address is included above.	



Detach and Mail or Fax the Form Above



TO ORDER PARTS

If there are missing or damaged parts, you can go to parts.staminaproducts.com and order those parts. If you have questions, please contact customer care. Do not return the product. To order parts by mail, fill out the sheet below and fax it to 417-889-8064. The part will be mailed to your address.



Detach and Mail or Fax the Form Below



PARTS ORDER FORM	Stamina Products, Inc. 4435 West Manufacturers Street, Springfield, MO 65803	
Mr./Ms:		
Address: Apt. #:		
City: State: Zip Code:		
IMPORTANT : We require your phone number to process the order!		
Phone #: () Work Phone #: ()		
Date of Purchase:		
Model #:		
Purchased From:		
IMPORTANT: Before filling out the portion below, make sure you have the correct information. Refer to the parts list to make sure you're ordering the right parts!		
PART #	DESCRIPTION	QUANTITY
EXAMPLE: 1	Rear Unit Assembly	1